

## Main Index

<b>UL</b> <b>Index</b>	<b>Index</b> .....	A01 - A02
<b>A</b> <b>UL</b>	<b>Profiles</b>	
	Specification Pages.....	A03 - A06
	Technical Information.....	A07 - A10
	Scale Profile Drawings.....	A11 - A20
<b>B</b> <b>UL</b>	<b>Accessories</b>	
	Photos & Drawings.....	B03 - B16
<b>C</b> <b>UL</b>	<b>Sections</b>	
	Scale Elevations.....	C03 - C22
<b>D</b> <b>UL</b>	<b>Statics</b> .....	D01 - D02
<b>E</b> <b>UL</b>	<b>Construction Drawings</b>	
	Corner Joint Details.....	E03
	Corner Crimping.....	E04
	Cill Drainage.....	E05
	Window Drainage.....	E06
	Tilt & Turn Outer Frame & Sash.....	E07 - E08
	Tilt & Turn Overview.....	E09
	ACUN3140.....	E10
	Mullion/Transom Detail	E11
	Glazing Chart.....	E12
<b>F</b> <b>UL</b>	<b>Sawing Tables</b>	
	Cutting Information.....	F03 - F14

**Updates**

DATE	PAGE	DESCRIPTION

## Specification

### GENERAL DESCRIPTION

The "Visotherm Tilt & Turn" window system described in this manual is suitable for both replacement windows for existing buildings, and for installation into new buildings.

The system incorporates internally beaded fixed lights & sashes.

The low line gaskets and extended polyamide thermal breaks help to provide excellent U Values and Window Energy Rating capable of achieving an 'A' Rating when used in conjunction with the correct double glazed unit.

### PROFILE SPECIFICATION

The window frame are constructed of aluminium alloy extrusion to BS EN 755-9 and BS EN 12020, extruded to 6063 T6 alloy. The internal and external extrusions are separated with a polyamide thermal break.

The external aluminium alloy extrusion is pre-treated and finished either:-

- a) Anodised to BS 3987: 1987, grade AA25 to a natural self colour.
- b) Polyester powder organic coating to BS 6496. Dual colour is available.

### GENERAL MANUFACTURING

Outer and vent frames are made by cutting the frame profiles with accurate 45° mitred ends using Tungsten Carbide Tipped Saw Blades, operating at approximately 3000 rpm.

The corners are joined using the Visotherm Tilt & Turn crimping cleats to form a cold forged corner joint (made by deforming small slugs of metal into the groove of the corner cleat).

The ends of transoms and mullions are profiled to fit the frame and fixed using self-tapping screws with a small joint sealant.

On polyester powder coated finishes, great care should be taken to avoid getting gap sealer on visible surfaces and should be removed as soon as possible with a clean cloth.

Care should be exercised when using products not supplied by Smart Systems Ltd as no responsibility can be accepted.

## Specification

### WINDOW DRAINAGE

As with all dry glazed systems, it is recommended that the window system is adequately drained and ventilated. Refer to drainage details in manual, if in doubt ask The Technical Department.

### OUTER FRAME MANUFACTURING INFORMATION

The outer frame members are cut with 45° mitred ends to the overall size required, measured to the longest point of the metal.

Prior to corner crimping the centre line position of any transoms or mullions should be marked on the outer frame members. Where the transom/mullion runs right through, it should be marked out on both jambs or head and cill members in pairs to ensure accurate alignment of the sections.

Using the marked centre line, Drill the transom/mullion fixing holes using a 5mm dia. drill bit.

Corners are formed by coating the cut faces to be joined with a suitable small gap sealer. Into the mitred corner insert the cleat glue and the required corner cleats and, where required, the aluminium corner chevrons. The two mitred ends are then brought together and crimped. The small gap sealer ensures a permanent joint and guards against the ingress of moisture and joint movement. After crimping the corner joint, special care should be taken to ensure any excess sealer is removed from painted surfaces.

Transoms or mullions are cut with square ends to the sizes calculated on the cutting formula sheets. The ends are then profiled to allow them to fit into the outer frame. Special tooling is available on request to profile the end of transom/mullion.

Prior to fixing of transoms and mullions smear the cut ends with a suitable small gap sealer. After fixing, special care should be taken to ensure any excess is cleared from painted surfaces.

### VENT

Prior to crimping the vents, remove the corners to the hardware channels to allow assembly of the tilt & turn hardware.

Corners are formed by coating the cut faces to be joined with a suitable gap sealer. In the mitred corner insert the cleat glue and the required corner cleats and chevrons. The mitred ends are then brought together and crimped. The small gap sealer ensures a permanent joint and guards against the ingress of moisture and joint movement. Care should be taken to ensure any excess sealer is removed from the surfaces.

For advise on window sizes outside of the recommended design limitations, please contact the Technical Department at Smart Systems Ltd Tel: 01934 876100

## Specification

### GLAZING

All beads are cut to suit the glazing aperture on the fully assembled window for glazing either at factory or on site as required.

### INTERNALLY BEADED GLAZING

Glazing beads are fitted to openings by cutting the horizontal beads square to head and cill of each vent and fixed light area. Vertical beads are cut square at both ends. Insert bottom beads and two setting blocks to ensure glass will be centralized in vertical dimension of opening (glazing blocks must be full width of cavity to fully support glass or sealed unit), then insert top bead followed by side beads. Finish glazing by insertion of internal gaskets all round.

### Hardware

For Hardware components, please refer to the SB-Chrono manual.

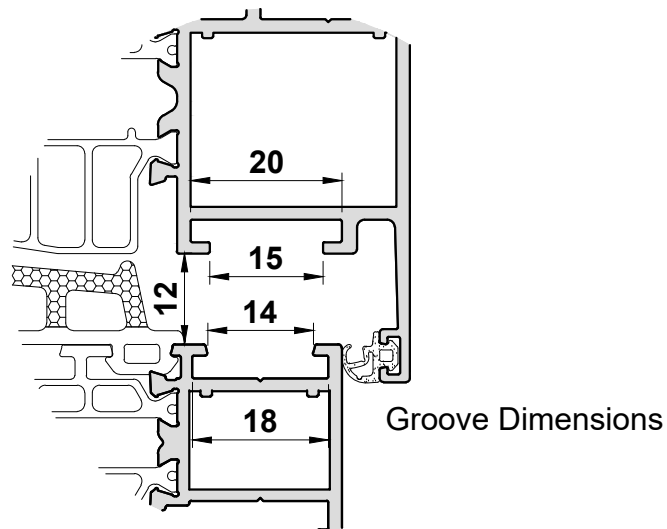

## Specification

### **Visotherm Tilt & Turn Window Weather Performance (BS6375-1) Audited and assessed by BSI. Kitemark KM81580**

BS EN 1026: 2000 Air Permeability: Class 4

BS EN 1027: 2000 Watertightness: Class 9A

BS EN 12211: 2000 Resistance to Wind Load: BE2400

### **Visotherm Tilt & Turn Window Security (PAS 24) Audited and assessed by BSI. Kitemark KM81580**

PAS24:2022





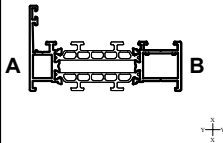
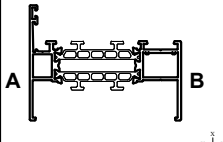
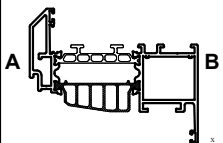
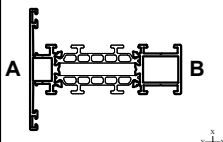
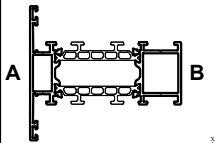
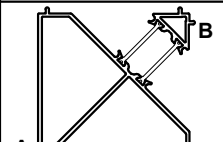
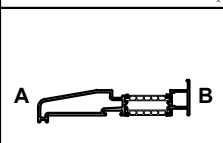
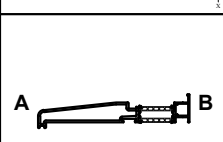
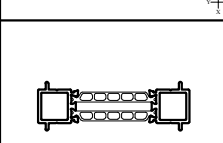

### **Visotherm Tilt & Turn Window U Values**

Please refer to the Smart Systems' Document L White Paper or contact the Technical Department.

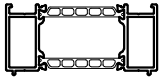
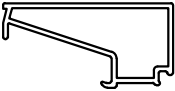
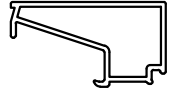
**PROFILES : TECHNICAL INFORMATION**

Number	Picture	Page	Perim. mm	Mec. mm	lx(cm4) wx(cm3)	ly(cm4) wy(cm3)	Length	Pack pr.	MF	SA	KL	HP	M	
<b>UL115</b>		A11	331	87	35.45 — 8.13	3.56 — 2.14	6.5	1	✓	✓	✓	✓	✓	
<b>UL116</b>		A11	363	119	43.71 — 10.26	6.72 — 2.30	6.5	1	✓	✓	✓	✓	✓	
<b>UL125</b>		A12	417	107	63.34 — 13.74	13.02 — 3.95	6.5	1	✓	✓	✓	✓	✓	
<b>UL135</b>		A13	416	107	40.68 — 8.56	6.66 — 2.08	6.5	1	✓	✓	✓	✓	✓	
<b>UL136</b>		A13	430	121	47.68 — 10.74	10.88 — 3.06	6.5	1	✓	✓	✓	✓	✓	
<b>UL048</b>		A16	428	161	67.01 — 14.96	67.01 — 17.59	6.5	1	✓	✓	✓	✓	✓	
<b>UL050</b>		A14	423	184	168.01 — 21.16	6.22 — 3.42	6.5	1	✓	✓	✓	✓	✓	
<b>UL051</b>		A14	503	224	330.03 — 32.58	8.14 — 4.55	6.5	1	✓	✓	✓	✓	✓	
<b>UL055</b>		A15	224	37	26.65 — 6.66	1.29 — 1.13	6.5	1	✓	✓	✓	✓	✓	
									A = Outside B = Inside		MF = Mill Finish SA = Silver Anodised KL = Basic Colour HP = Special Colour M = Dual Colour			

PROFILES : TECHNICAL INFORMATION

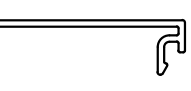
Number	Picture	Page	Perim. mm	Mec. mm	lx(cm4) wx(cm3)	ly(cm4) wy(cm3)	Length	Pack pr.	MF	SA	KL	HP	M	
<b>UL056</b>		A15	300	71	38.49 — 9.62	5.74 — 3.15	6.5	1	✓	✓	✓	✓	✓	
<b>UL063</b>		A17	143	64	- — -	- — -	6.5	1	✓	✓	✓	✓		
<b>UL064</b>		A17	136	60	- — -	- — -	6.5	1	✓	✓	✓	✓		
<b>UL065</b>		A17	129	57	- — -	- — -	6.5	1	✓	✓	✓	✓		
<b>UL066</b>		A17	118	51	- — -	- — -	6.5	1	✓	✓	✓	✓		
<b>UL067</b>		A18	111	46	- — -	- — -	6.5	1	✓	✓	✓	✓		
<b>UL068</b>		A18	102	41	- — -	- — -	6.5	1	✓	✓	✓	✓		
<b>UL069</b>		A18	87	37	- — -	- — -	6.5	1	✓	✓	✓	✓		
<b>UN500</b>		A19	137.3	52	- — -	- — -	6.5	1	✓	✓	✓	✓		
									A = Outside B = Inside		MF = Mill Finish SA = Silver Anodised KL = Basic Colour HP = Special Colour M = Dual Colour			

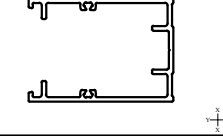
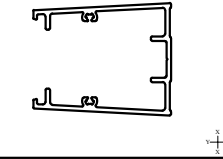
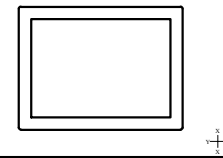

**PROFILES : TECHNICAL INFORMATION**

Number	Picture	Page	Perim. mm	Mec. mm	lx(cm4) wx(cm3)	ly(cm4) wy(cm3)	Length	Pack pr.	MF	SA	KL	HP	M	
<b>UN501</b>		A19	135.9	45	- -	- -	6.5	1	✓	✓	✓	✓		
<b>UN510</b>		A19	374.5	113	12.2 3.8	9.5 4.8	6.5	1	✓	✓	✓	✓		
<b>UN511</b>		A19	394.4	113.1	12.9 4.0	11.6 5.1	6.5	1	✓	✓	✓	✓		
<b>UTL080</b>		A19	139.2	139.2	8.2 4.1	5.1 3.4	6.5	1	✓					
									A = Outside B = Inside		MF = Mill Finish SA = Silver Anodised KL = Basic Colour HP = Special Colour M = Dual Colour			

PROFILES : TECHNICAL INFORMATION

Number	Picture	Page	Perim. mm	Mec. mm	lx(cm4) wx(cm3)	ly(cm4) wy(cm3)	Length	Pack pr.	MF	SA	KL	HP	M
									A = Outside B = Inside	MF = Mill Finish SA = Silver Anodised KL = Basic Colour HP = Special Colour M = Dual Colour			

Primary Visible Side

Secondary Visible Side

## UL115 Outer Frame

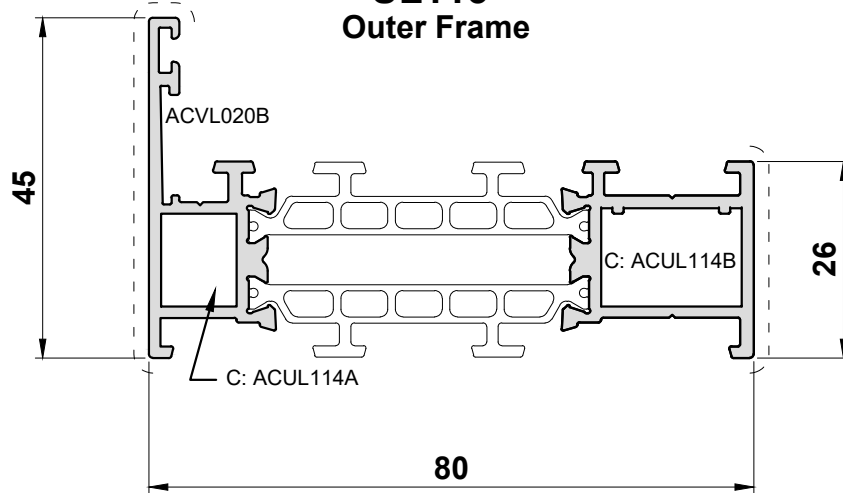

## UL116 Long Leg Outer Frame

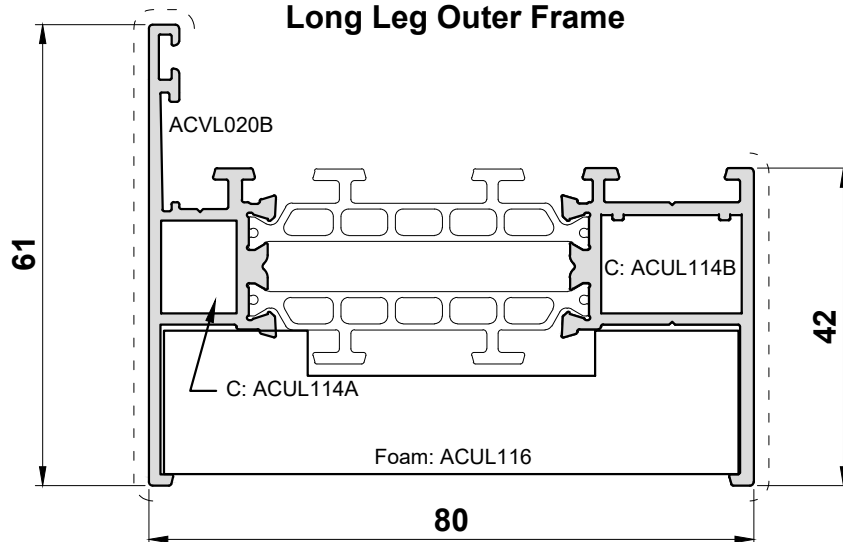

Scale 1:1

Primary Visible Side

Secondary Visible Side

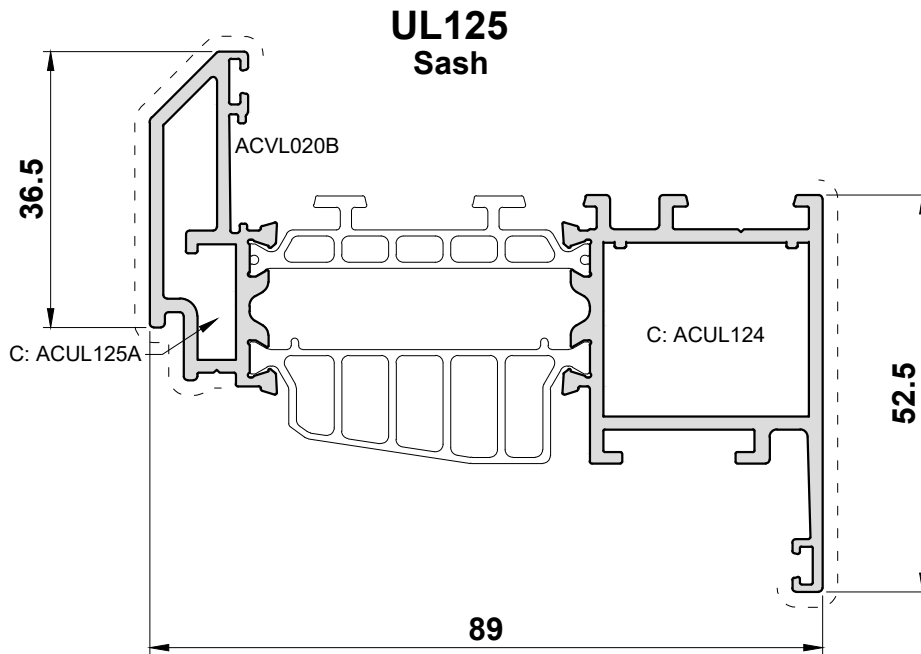

Scale 1:1

Primary Visible Side

Secondary Visible Side

## UL135 Transom / Mullion

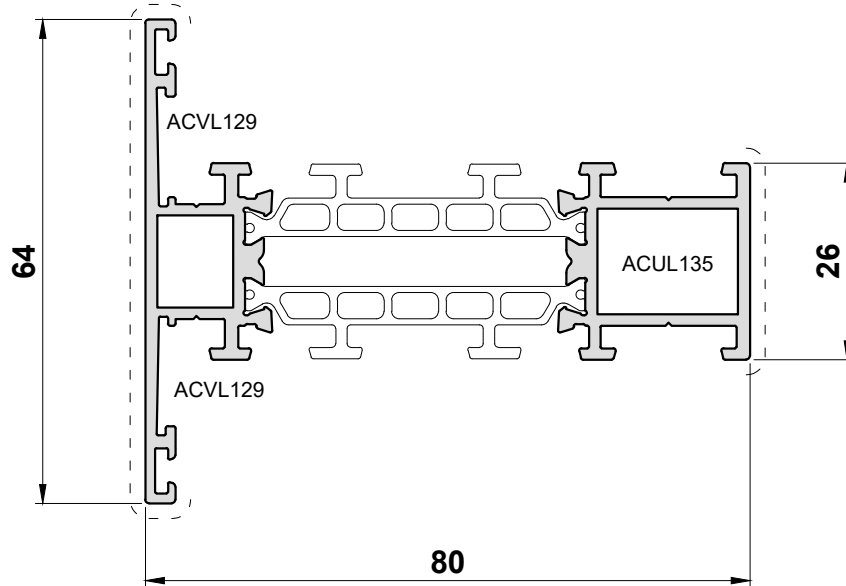

## UL136 Transom / Mullion

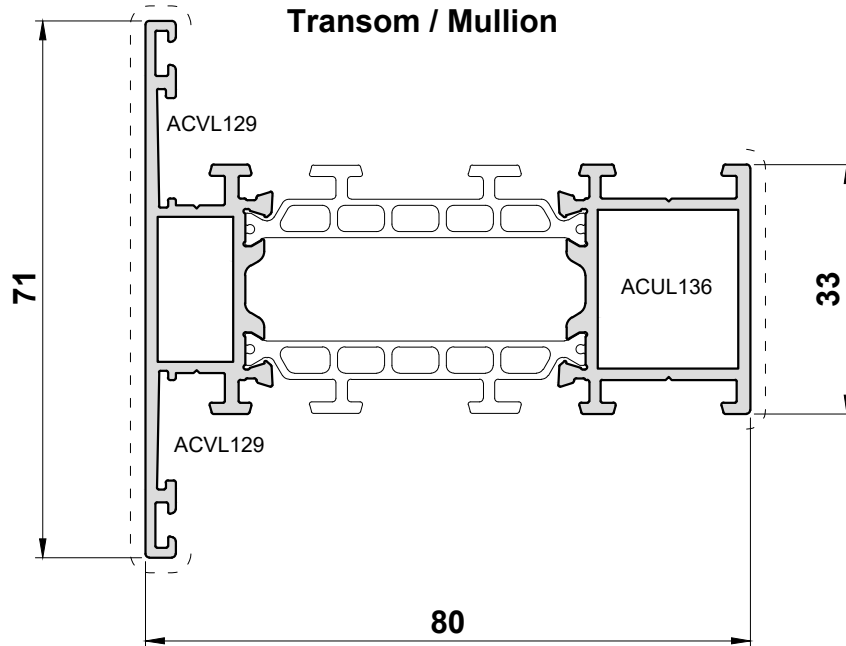

Scale 1:1

Primary Visible Side

Secondary Visible Side

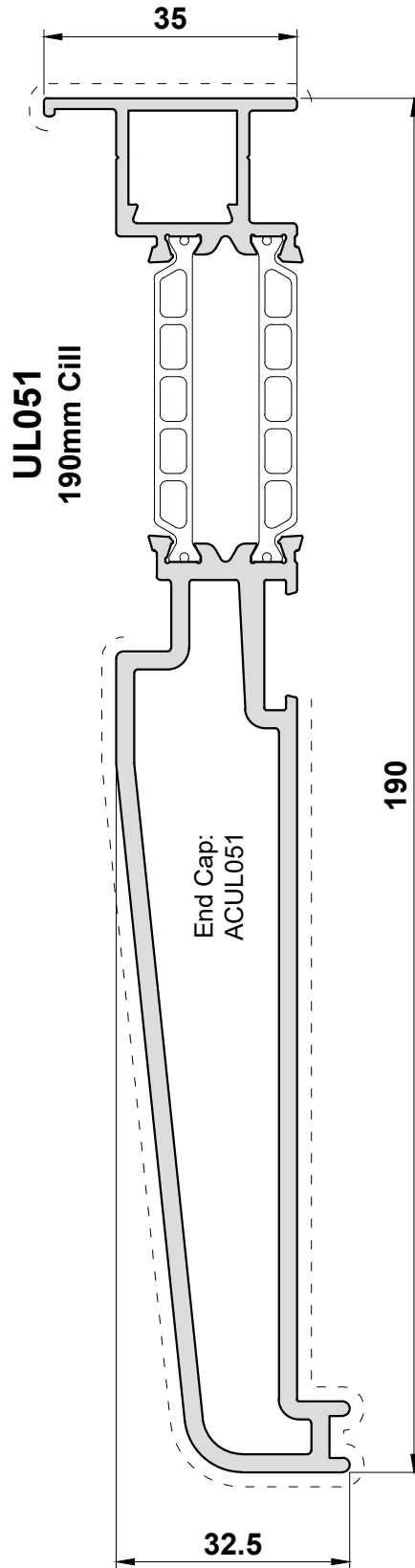
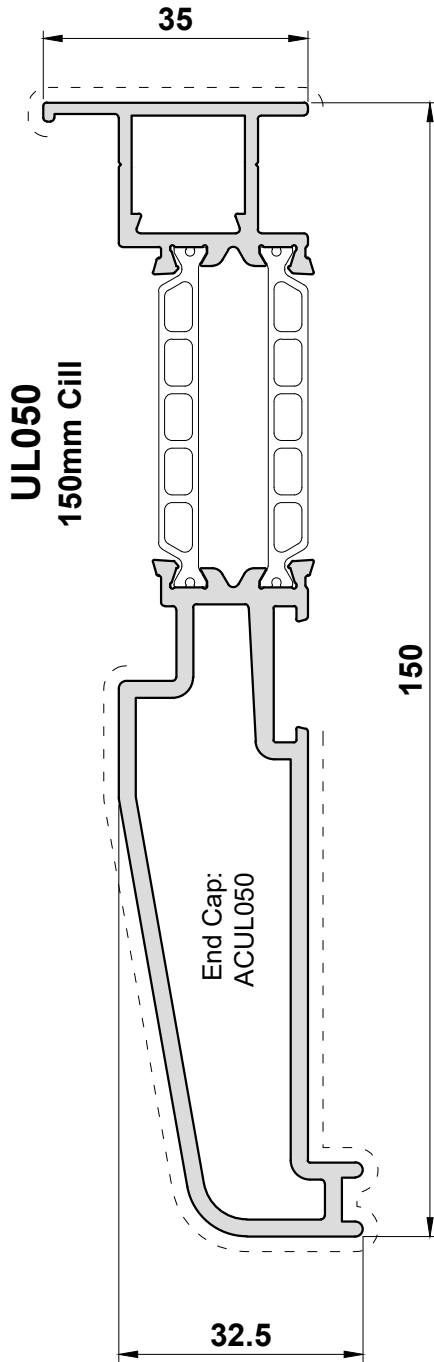

Scale 1:1

Primary Visible Side

Secondary Visible Side

**UL055**  
Coupler

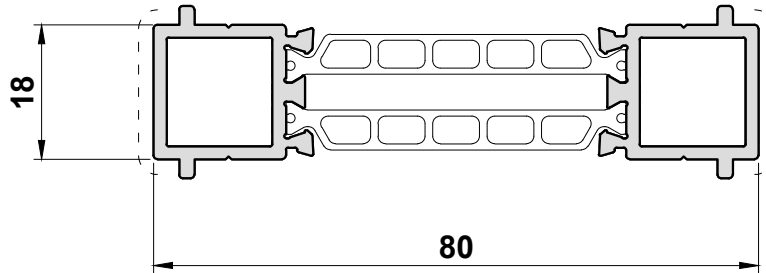

**UL056**  
35mm Head Extension

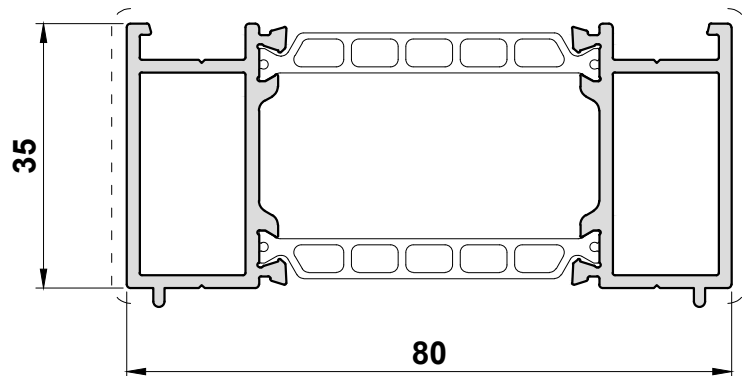

Scale 1:1

Primary Visible Side

Secondary Visible Side

**UL048**  
90° Corner Post

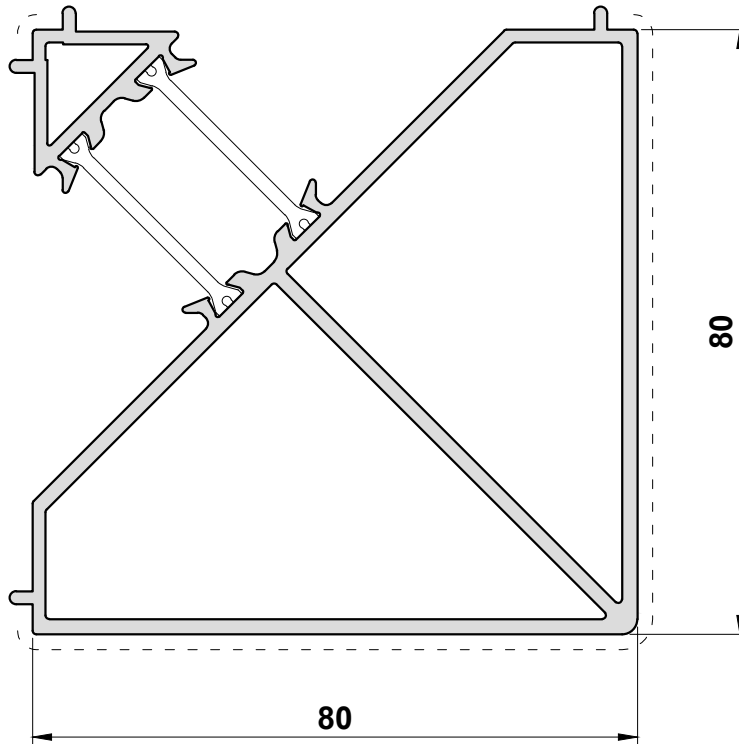

Scale 1:1



Primary Visible Side

Secondary Visible Side

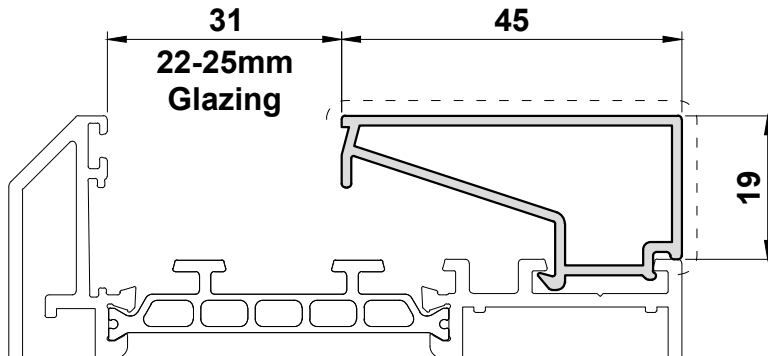

**UL063**  
22-25mm Glazing Bead

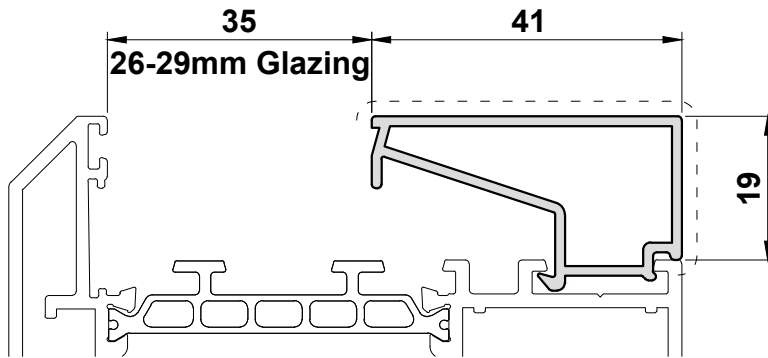

**UL064**  
26-29mm Glazing Bead

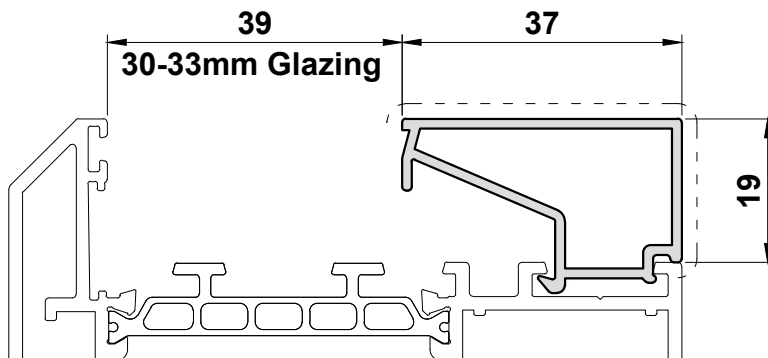

**UL065**  
30-32mm Glazing Bead

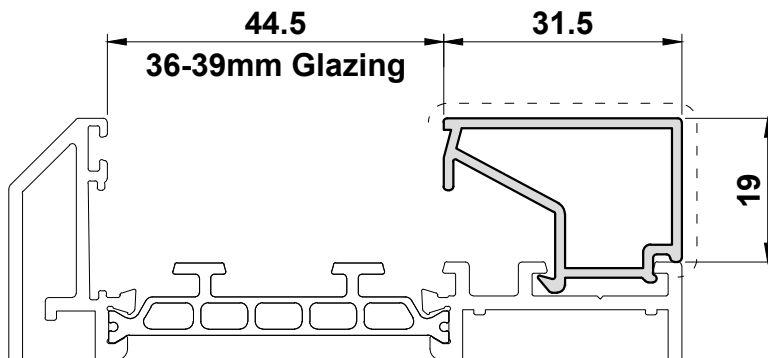

**UL066**  
36-39mm Glazing Bead

Scale 1:1

Primary Visible Side

Secondary Visible Side

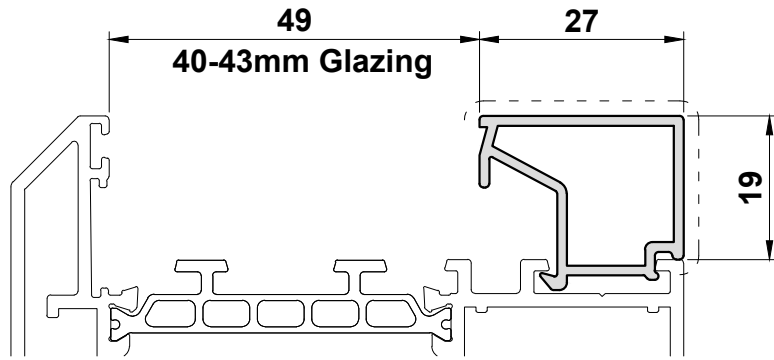

**UL067**  
40-43mm Glazing Bead

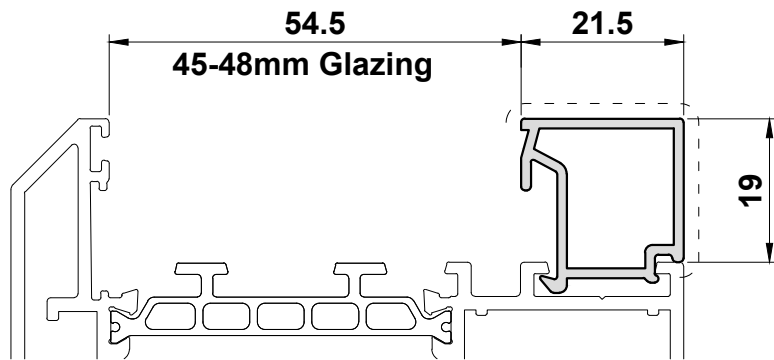

**UL068**  
45-48mm Glazing Bead

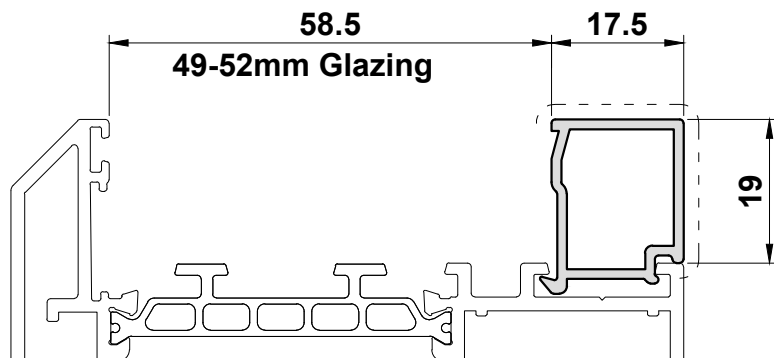

**UL069**  
49-52mm Glazing Bead

Scale 1:1

Primary Visible Side

Secondary Visible Side

**UN500**  
UN510 Cover Cap

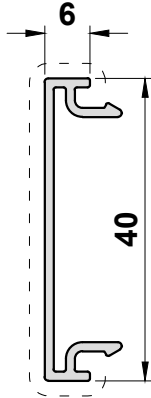

**UN510**  
Reinforcement Profile

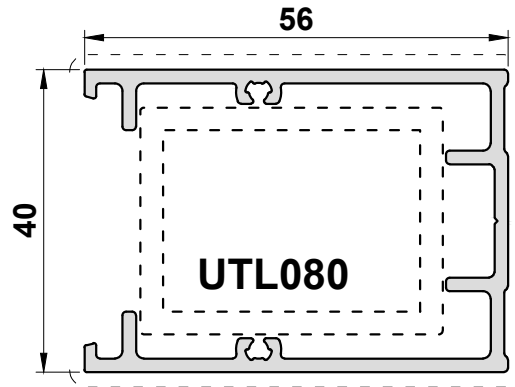

UN510  
End Cap:  
ACUN500

**UN501**  
UN511 Cover Cap

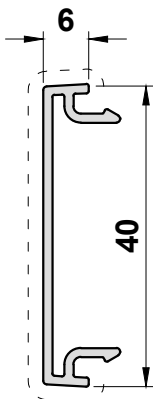

**UN511**  
Reinforcement Profile

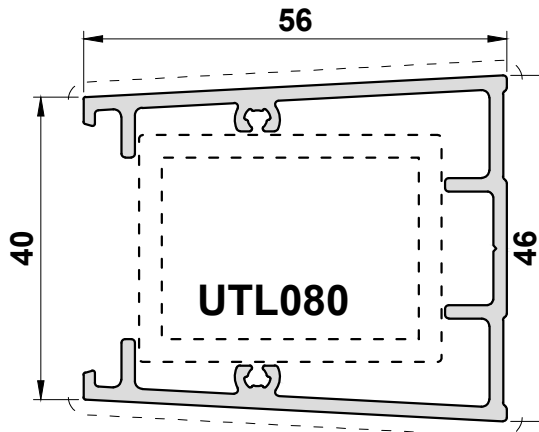

UN511  
End Cap:  
ACUN501

**UTL080**  
Reinforcement Profile

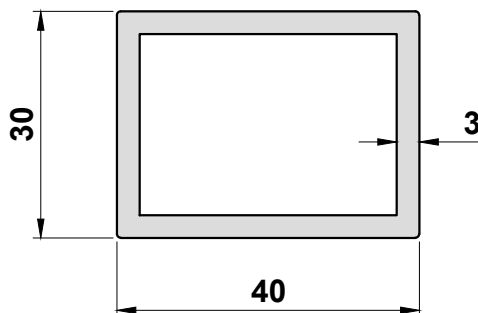

Scale 1:1

Primary Visible Side

Secondary Visible Side

Scale 1:1

**Section B**

**Accessories**

**Photos & Drawings**

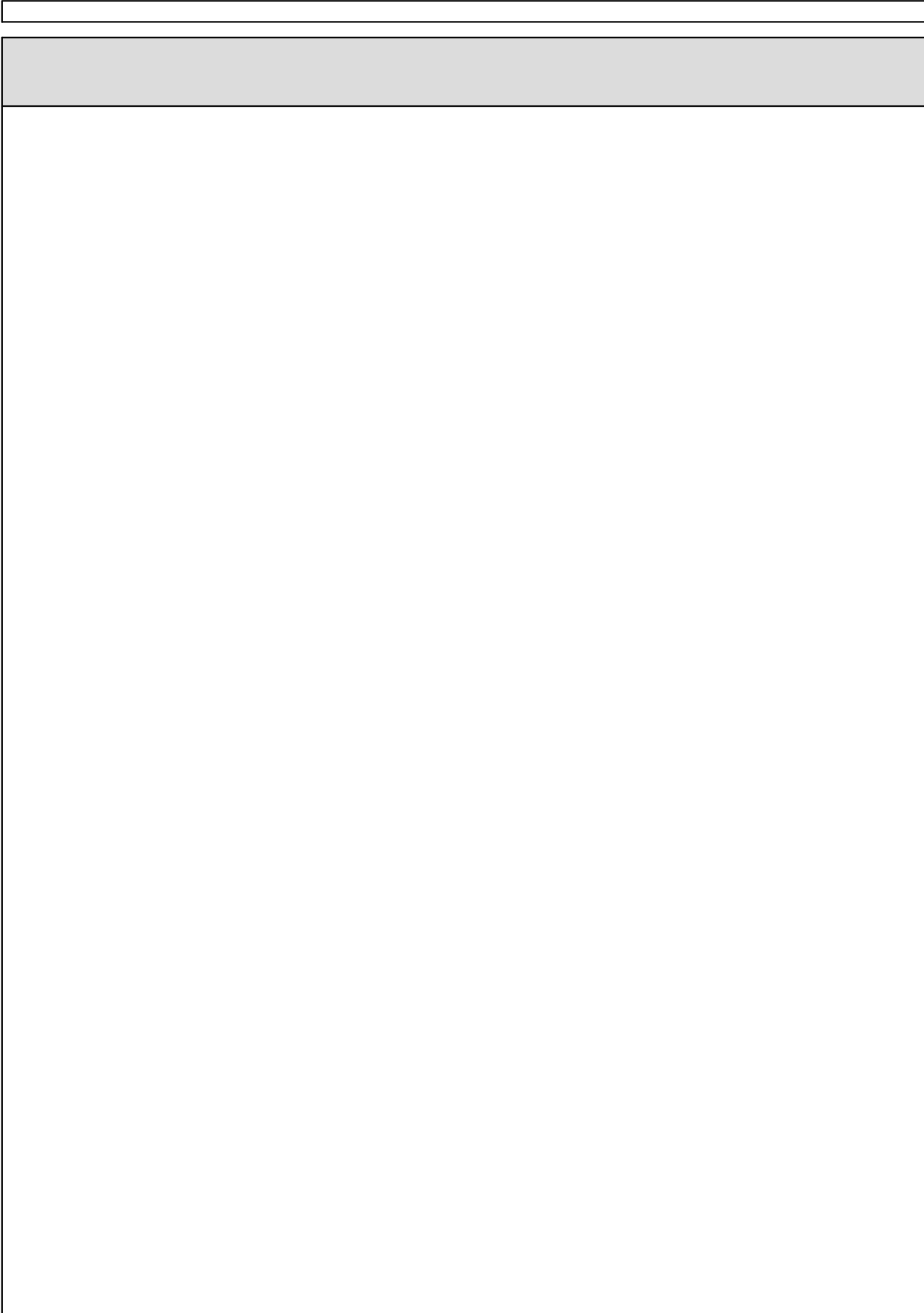

**Corner Joint - Crimping**

	Profile	Crimping Punches	Vee Block	Packer
Outerframe	UL115	ACUL919	ACUL916	ACUL917
Sash	UL125	ACUL918	ACUL916	ACUL917

**PNEUMATIC CRIMPER**  
ACCR100

**MANUAL CRIMPER**  
WUT024HSZA

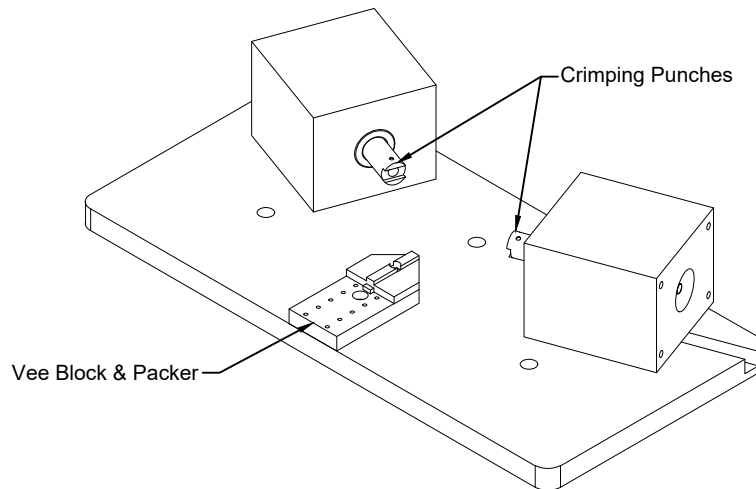

**Countersunk Screws**

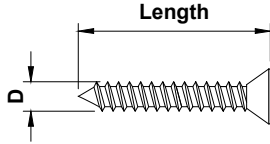

Gauge	'D' (mm)
No.6	3.5
No.7	3.8
No.8	4
No.10	5
No.12	6

Part Number	Gauge	X	Length	Description	Box Qty.
ACUN3530	No.6	X	5/8"	Countersunk Pozi Self Tapper S/S	100
MUA025SSZ	No.6	X	1"	Countersunk Pozi Self Tapper S/S	100
ACET067	No.7	X	1/2"	Countersunk Pozi Self Tapper S/S	100
ACET060	No.7	X	1"	Countersunk Pozi Self Tapper S/S	100
ACET066	No.7	X	1 1/2"	Countersunk Pozi Self Tapper S/S	100
MUA067SSZ	No.7	X	2"	Countersunk Pozi Self Tapper S/S	100
ACUN3544	No.7	X	3/4"	Countersunk Pozi Self Tapper S/S	100
ACET064	No.8	X	5/8"	Countersunk Pozi Self Tapper S/S	100
ACUN3512	No.8	X	1 1/4"	Countersunk Pozi Self Tapper S/S	100
ACUN3513	No.8	X	1 3/4"	Countersunk Pozi Self Tapper S/S	100
ACET072	No.8	X	2 1/2"	Countersunk Pozi Self Tapper S/S	100
ACET490	4.3mm	X	16mm	Countersunk PH2 Polyamide Screw	1000
ACET290	4.3mm	X	20mm	Countersunk PH2 Polyamide Screw	100
ACET390	4.3mm	X	25mm	Countersunk PH2 Polyamide Screw	200
ACET190	4.3mm	X	45mm	Countersunk PH2 Polyamide Screw	1000
ACVS062	4.3mm	X	65mm	Countersunk PH2 Polyamide Screw	1000
ACET048	No.10	X	3/8"	Countersunk Pozi Self Tapper S/S	100
ACIM062	No.10	X	1 1/4"	Countersunk Pozi Self Tapper S/S	100
ACET062	No.10	X	2"	Countersunk Pozi Self Tapper S/S	100
ACET076	No.10	X	2 1/2"	Countersunk Pozi Self Tapper S/S	100



**Pan Head Screws**

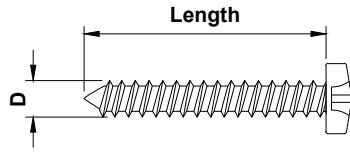

Gauge	'D' (mm)
No.6	3.5
No.7	3.8
No.8	4
No.10	5
No.12	6

Part Number	Gauge	X	Length	Description	Box Qty.
ACET068	No.8	X	3/8"	Pozi Flange AB	100
ACET063	No.8	X	1/2"	Pan Head Self Tapper	100
ACET070	No.8	X	1/2"	Pozi Flange Self Tapper S/S	100
ACUN3535	No.8	X	5/8"	Pan Head Pozi S/S	100
ACET099	No.8	X	3/4"	Pozi Flange Self Tapper S/S	100
ACDR050	4.8mm	X	32mm	Pan Head Pozi S/S	200
PUA028	No.10	X	1"	Pan Head Pozi S/S	100
ACDR052	No.10	X	2"	Pan Head Self Tapper S/S	200
ACET079	No.10	X	2 1/2"	Pan Head Pozi S/S	100
ACW20160	No.12	X	1"	Flange Head Self Tapper S/S	100
ACMC109	6.3mm	X	38mm	DIN7981 - Pan Head Self Tapper	200

## Machine Screws

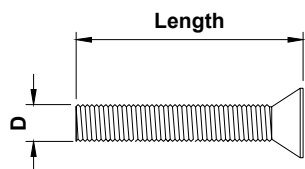





Thread	'D' (mm) Nominal
M4	4
M5	5
M6	6
M8	8
M10	10

Part Number	Thread	X	Length	Description	Box Qty.
ACET122	M4	X	10	CSK Pozi Machine Screw	100
ACET123	M4	X	20	CSK Pozi Machine Screw	100
ACDV264	M4	X	35	CSK Pozi Machine Screw	100
ACSG071	M4	X	40	CSK Pozi Machine Screw	100
ACDV266	M4	X	45	CSK Pozi Machine Screw	100
ACDV262	M4	X	50	CSK Pozi Machine Screw	100
ACDV265	M4	X	60	CSK Pozi Machine Screw	100
ACDR051	M5	X	10	CSK Pozi Machine Screw	100
ACET069	M5	X	12	CSK Pozi Machine Screw	100
HEA132	M5	X	16	CSK Pozi Machine Screw	100
WCA134	M5	X	20	CSK Pozi Machine Screw	100
WCA143	M5	X	25	CSK Pozi Machine Screw	50
ACVS061	M5	X	40	CSK Pozi Machine Screw	100
ACET133	M5	X	50	CSK Pozi Machine Screw	100
ACET220	M5	X	60	CSK Pozi Machine Screw	100
ACET238	M5	X	70	CSK Pozi Machine Screw	100
ACMX861	M5	X	80	DIN965 - CSK Machine Screw	10
ACMX862	M5	X	90	DIN965 - CSK Machine Screw	10
ACUN3503	M6	X	10	CSK Socket Machine Screw	24
ACUN3501	M6	X	13	CSK Flange Socket Machine Screw	48
ACMX852	M6	X	16	DIN965 - CSK Machine Screw	10
HEA390	M6	X	16	CSK Socket Machine Screw	32
ACET235	M6	X	60	CSK Pozi Machine Screw	100
ACET237	M6	X	70	CSK Pozi Machine Screw	100

## Glazing Gaskets

### Retaining Gasket







Commonly known as an E Gasket.  
Retaining gaskets create a seal between the Glass and the Aluminium Profile.

High Line	Thickness		Part number		
			Coil length	Available Colours	
High Line	2mm		<b>ACVG231</b>	200m	BL
			<b>ACVG31</b>	200m	BL
			<b>ACVG131</b>	100m	BL
Low Line	2mm		<b>ACET844</b>	200m	BL
			<b>ACET842</b>	200m	BL
			<b>ACET841</b>	200m	BL
	3mm		<b>ACET842</b>	200m	BL
			<b>ACET841</b>	200m	BL
			<b>ACET835</b>	200m	BL
4mm		<b>ACET835</b>	200m	BL	
		<b>ACET835</b>	200m	BL	

Thickness	Drawing 1:1	Part number
		Coil length
		Available Colours

### Wedge Gasket



Wedge Gaskets help to hold the bead in place by providing tension between the bead and the glazing unit.

High Line	Thickness		Part number		
			Coil length	Available Colours	
High Line	3mm		<b>ACVG32</b>	100m	BL
			<b>ACVG32N</b>	100m	BL
			<b>ACVG33</b>	100m	BL
	4mm		<b>ACVG33N</b>	100m	BL
			<b>ACVG34</b>	100m	BL
			<b>ACVG34N</b>	100m	BL
	5mm		<b>ACVG340</b>	200m	BL
			<b>ACVG340N</b>	100m	BL
			<b>ACVG340</b>	200m	BL
	6mm		<b>ACVG340</b>	200m	BL
			<b>ACVG340N</b>	100m	BL
			<b>ACVG340</b>	200m	BL
Low Line	4mm - 3mm		<b>ACW20038</b>	50m	BL
			<b>ACW20038</b>	50m	BL
			<b>ACW20038</b>	50m	BL
5mm - 4mm		<b>ACET848</b>	200m	BL	
		<b>ACET848</b>	200m	BL	



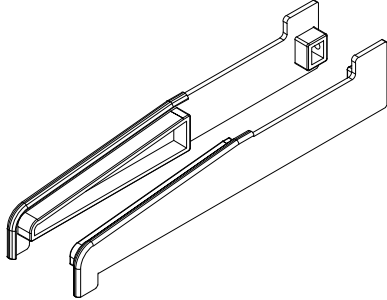
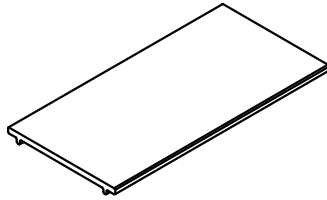
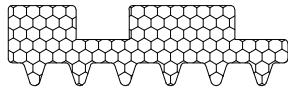
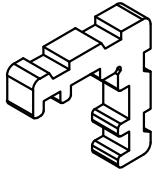
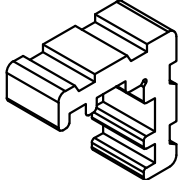

ACCESSORIES : PHOTOS & DRAWINGS

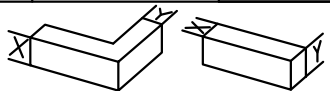
Image	Part Code	Pack	Unit	Application	Colour
	<b>ACGSL045</b>  <b>Drainage Cap</b>	100	Pack	<b>UL115</b> <b>UL116</b> <b>UL125</b> <b>UL135</b> <b>UL136</b>	MF SA KL HP SSC SMC W <input checked="" type="checkbox"/> Z <input checked="" type="checkbox"/> PC
	<b>ACGT060</b>  <b>Central Gasket</b>	20	m	<b>UL115</b> <b>UL116</b> <b>UL135</b> <b>UL136</b>	MF SA KL HP SSC SMC W Z <input checked="" type="checkbox"/> PC
	<b>ACGT062</b>  <b>5mm Flipper Gasket</b>	150	m	<b>UL125</b>	MF SA KL HP SSC SMC W Z PC
	<b>ACGT160</b>  <b>Corner Central Gasket</b>	24	Pack	<b>ACGT060</b>	MF SA KL HP SSC SMC W Z <input checked="" type="checkbox"/> PC
	<b>ACUL050</b>  <b>Cast Cill End Cap</b>	10	pair	<b>UL050</b>	MF SA KL <input checked="" type="checkbox"/> HP <input checked="" type="checkbox"/> SSC SMC W <input checked="" type="checkbox"/> Z <input checked="" type="checkbox"/> PC
	<b>MF</b> = Mill Finish <b>SA</b> = Silver Anodised <b>KL</b> = Basic Colour <b>HP</b> = Special Colour <b>SSC</b> = Smooth Satin Chrome <b>SMC</b> = Smokey Chrome <b>PC</b> = Polished Chrome	<b>W</b> = White <b>Z</b> = Black			



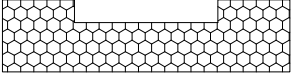
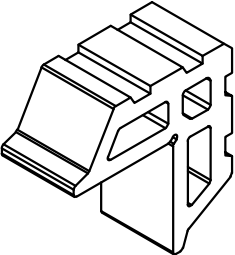
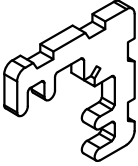

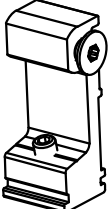
**ACCESSORIES : PHOTOS & DRAWINGS**

Image	Part Code	Pack	Unit	Application	Colour
	<b>ACUL051</b>  <b>Cast Cill End Cap</b>	<b>10</b>	<b>pair</b>	<b>UL051</b>	MF
					SA
					KL
					HP
					SSC
					SMC
					W
					Z
					PC
	<b>ACUL056</b>  <b>Bridge Packer</b>	<b>12</b>	<b>Pack</b>	<b>UL115</b> <b>UL116</b> <b>UL125</b> <b>UL135</b> <b>UL136</b>	MF
					SA
					KL
					HP
					SSC
					SMC
					W
					Z
					PC
	<b>ACUL062</b>  <b>Glazing Foam</b>	<b>1</b>	<b>Each</b>	<b>UL115</b> <b>UL116</b> <b>UL125</b> <b>UL135</b> <b>UL136</b>	MF
					SA
					KL
					HP
					SSC
					SMC
					W
					Z
					PC
	<b>ACUL114A</b>  <b>Crimping Cleat</b>	<b>24</b>	<b>Pack</b>	<b>UL115</b> <b>UL116</b>	MF
					SA
					KL
					HP
					SSC
					SMC
					W
					Z
					PC
	<b>ACUL114B</b>  <b>Crimping Cleat</b>	<b>24</b>	<b>Pack</b>	<b>UL115</b> <b>UL116</b>	MF
					SA
					KL
					HP
					SSC
					SMC
					W
					Z
					PC
 <small>T-BARS ACVG66=2.5mm ACVG66=3.0mm ACVL150=4.0mm</small>	 <small>Screw (Grub)</small>	<b>MF</b> = Mill Finish <b>SA</b> = Silver Anodised <b>KL</b> = Basic Colour <b>HP</b> = Special Colour <b>SSC</b> = Smooth Satin Chrome <b>SMC</b> = Smokey Chrome <b>PC</b> = Polished Chrome	<b>W</b> = White <b>Z</b> = Black		

ACCESSORIES : PHOTOS & DRAWINGS

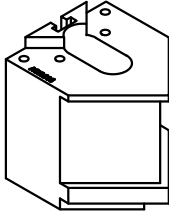
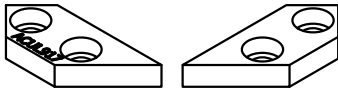
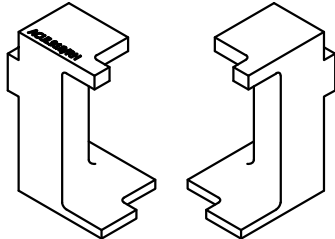
Image	Part Code	Pack	Unit	Application	Colour	
	<b>ACUL116</b>  <b>Perimeter Foam</b> <b>1250mm lengths</b>	<b>1</b>	<b>Each</b>	<b>UL116</b>	MF	
					SA	
					KL	
					HP	
					SSC	
					SMC	
					W	
					Z	✓
					PC	
						<b>ACUL124</b>  <b>Crimping Cleat</b>
SA	✓					
KL						
HP						
SSC						
SMC						
W						
Z						
PC						
	<b>ACUL125A</b>  <b>Crimping Cleat</b>	<b>24</b>	<b>Pack</b>	<b>UL125</b>		
					SA	✓
					KL	
					HP	
					SSC	
					SMC	
					W	
					Z	
					PC	
						<b>ACUL135</b>  <b>Mullion / Transom Cleat</b>
SA	✓					
KL						
HP						
SSC						
SMC						
W						
Z						
PC						
	<b>ACUL136</b>  <b>Mullion / Transom Cleat</b>	<b>10</b>	<b>Pack</b>	<b>UL136</b>		
					SA	✓
					KL	
					HP	
					SSC	
					SMC	
					W	
					Z	
					PC	
					 <small>T-BARS ACVG65=2.5mm ACVG66=3.0mm ACVL150=4.0mm</small>	 <small>Screw (Grub)</small>

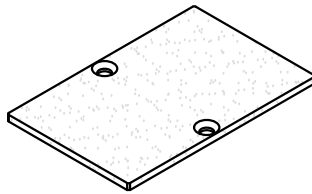
ACCESSORIES : PHOTOS & DRAWINGS

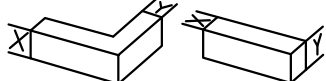
Image	Part Code	Pack	Unit	Application	Colour
	<b>ACUL916</b>  <b>Vee Block</b>	<b>1</b>	<b>Each</b>	<b>ACUL917</b> <b>UL115</b> <b>UL116</b> <b>UL125</b>	MF <input checked="" type="checkbox"/>
					SA <input type="checkbox"/>
					KL <input type="checkbox"/>
					HP <input type="checkbox"/>
					SSC <input type="checkbox"/>
					SMC <input type="checkbox"/>
					W <input type="checkbox"/>
					Z <input type="checkbox"/>
					PC <input type="checkbox"/>
					PC <input type="checkbox"/>
	<b>ACUL917</b>  <b>Packers</b>	<b>1</b>	<b>Pair</b>	<b>ACUL916</b> <b>UL115</b> <b>UL116</b> <b>UL125</b>	MF <input checked="" type="checkbox"/>
					SA <input type="checkbox"/>
					KL <input type="checkbox"/>
					HP <input type="checkbox"/>
					SSC <input type="checkbox"/>
					SMC <input type="checkbox"/>
					W <input type="checkbox"/>
					Z <input type="checkbox"/>
					PC <input type="checkbox"/>
					PC <input type="checkbox"/>
	<b>ACUL918</b>  <b>Punches</b>	<b>1</b>	<b>Pair</b>	<b>UL125</b>	MF <input checked="" type="checkbox"/>
					SA <input type="checkbox"/>
					KL <input type="checkbox"/>
					HP <input type="checkbox"/>
					SSC <input type="checkbox"/>
					SMC <input type="checkbox"/>
					W <input type="checkbox"/>
					Z <input type="checkbox"/>
					PC <input type="checkbox"/>
					PC <input type="checkbox"/>
	<b>ACUL919</b>  <b>Punches</b>	<b>1</b>	<b>Pair</b>	<b>UL115</b> <b>UL116</b>	MF <input checked="" type="checkbox"/>
					SA <input type="checkbox"/>
					KL <input type="checkbox"/>
					HP <input type="checkbox"/>
					SSC <input type="checkbox"/>
					SMC <input type="checkbox"/>
					W <input type="checkbox"/>
					Z <input type="checkbox"/>
					PC <input type="checkbox"/>
					PC <input type="checkbox"/>
	<b>ACUN500</b>  <b>Cover plate</b>	<b>1</b>	<b>Each</b>	<b>UN500</b> <b>UN510</b>	MF <input type="checkbox"/>
					SA <input type="checkbox"/>
					KL <input checked="" type="checkbox"/>
					HP <input checked="" type="checkbox"/>
					SSC <input type="checkbox"/>
					SMC <input type="checkbox"/>
					W <input checked="" type="checkbox"/>
					Z <input checked="" type="checkbox"/>
					PC <input type="checkbox"/>
					PC <input type="checkbox"/>
 <p>T-BARS ACVG66=2.5mm ACVG66=3.0mm ACVL150=4.0mm</p>  <p>Screw (Grub)</p>	<b>MF</b> = Mill Finish <b>SA</b> = Silver Anodised <b>KL</b> = Basic Colour <b>HP</b> = Special Colour <b>SSC</b> = Smooth Satin Chrome <b>SMC</b> = Smokey Chrome <b>PC</b> = Polished Chrome	<b>W</b> = White <b>Z</b> = Black			

**ACCESSORIES : PHOTOS & DRAWINGS**

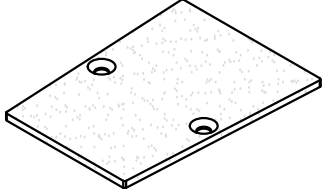
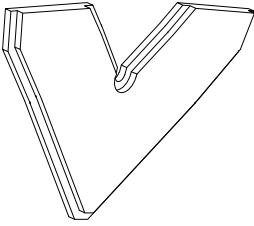
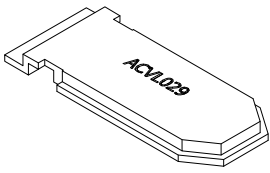
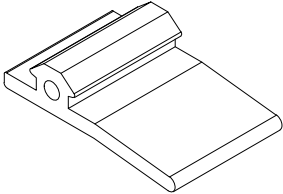

Image	Part Code	Pack	Unit	Application	Colour
	<b>ACUN501</b>  Cover plate	1	Each	<b>UN500</b> <b>UN511</b>	MF
					SA
					KL
					HP
					SSC
					SMC
					W
					Z
					PC
					
SA					
KL					
HP					
SSC					
SMC					
W					
Z					
PC					
	<b>ACVL029</b>  Strengthening piece for connecting bracket	100	Pack	<b>UL135</b> <b>UL136</b>	
					SA
					KL
					HP
					SSC
					SMC
					W
					Z
					PC
					
SA					
KL					
HP					
SSC					
SMC					
W					
Z					
PC					
	<b>MF</b> = Mill Finish <b>SA</b> = Silver Anodised <b>KL</b> = Basic Colour <b>HP</b> = Special Colour <b>SSC</b> = Smooth Satin Chrome <b>SMC</b> = Smokey Chrome <b>PC</b> = Polished Chrome	<b>W</b> = White <b>Z</b> = Black		MF	
				SA	
				KL	
				HP	
				SSC	
				SMC	
				W	
				Z	
				PC	







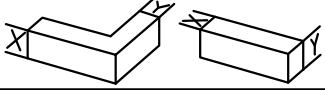
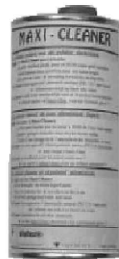

Image	Part Code	Pack	Unit	Application	Colour																		
	<b>ACMX09700</b>  <b>Alu. Polish</b>	<b>1</b>	<b>each</b>		<table border="1"> <tr><td>MF</td><td>✓</td></tr> <tr><td>SA</td><td></td></tr> <tr><td>KL</td><td></td></tr> <tr><td>HP</td><td></td></tr> <tr><td>SSC</td><td></td></tr> <tr><td>SMC</td><td></td></tr> <tr><td>W</td><td></td></tr> <tr><td>Z</td><td></td></tr> <tr><td>PC</td><td></td></tr> </table>	MF	✓	SA		KL		HP		SSC		SMC		W		Z		PC	
MF	✓																						
SA																							
KL																							
HP																							
SSC																							
SMC																							
W																							
Z																							
PC																							
	<b>ACMX09761</b>  <b>Maxi Gloss</b>	<b>1</b>	<b>each</b>		<table border="1"> <tr><td>MF</td><td></td></tr> <tr><td>SA</td><td></td></tr> <tr><td>KL</td><td></td></tr> <tr><td>HP</td><td></td></tr> <tr><td>SSC</td><td></td></tr> <tr><td>SMC</td><td></td></tr> <tr><td>W</td><td></td></tr> <tr><td>Z</td><td></td></tr> <tr><td>PC</td><td></td></tr> </table>	MF		SA		KL		HP		SSC		SMC		W		Z		PC	
MF																							
SA																							
KL																							
HP																							
SSC																							
SMC																							
W																							
Z																							
PC																							
	<b>ACMX09762</b>  <b>Alu. Bright</b>	<b>1</b>	<b>each</b>		<table border="1"> <tr><td>MF</td><td></td></tr> <tr><td>SA</td><td></td></tr> <tr><td>KL</td><td></td></tr> <tr><td>HP</td><td></td></tr> <tr><td>SSC</td><td></td></tr> <tr><td>SMC</td><td></td></tr> <tr><td>W</td><td></td></tr> <tr><td>Z</td><td></td></tr> <tr><td>PC</td><td></td></tr> </table>	MF		SA		KL		HP		SSC		SMC		W		Z		PC	
MF																							
SA																							
KL																							
HP																							
SSC																							
SMC																							
W																							
Z																							
PC																							
	<b>ACMX09763</b>  <b>Teflon Spray</b>	<b>1</b>	<b>each</b>		<table border="1"> <tr><td>MF</td><td></td></tr> <tr><td>SA</td><td></td></tr> <tr><td>KL</td><td></td></tr> <tr><td>HP</td><td></td></tr> <tr><td>SSC</td><td></td></tr> <tr><td>SMC</td><td></td></tr> <tr><td>W</td><td></td></tr> <tr><td>Z</td><td></td></tr> <tr><td>PC</td><td></td></tr> </table>	MF		SA		KL		HP		SSC		SMC		W		Z		PC	
MF																							
SA																							
KL																							
HP																							
SSC																							
SMC																							
W																							
Z																							
PC																							
	<b>ACMX09764</b>  <b>Maxi Clean</b>	<b>1</b>	<b>each</b>		<table border="1"> <tr><td>MF</td><td></td></tr> <tr><td>SA</td><td></td></tr> <tr><td>KL</td><td></td></tr> <tr><td>HP</td><td></td></tr> <tr><td>SSC</td><td></td></tr> <tr><td>SMC</td><td></td></tr> <tr><td>W</td><td></td></tr> <tr><td>Z</td><td></td></tr> <tr><td>PC</td><td></td></tr> </table>	MF		SA		KL		HP		SSC		SMC		W		Z		PC	
MF																							
SA																							
KL																							
HP																							
SSC																							
SMC																							
W																							
Z																							
PC																							
 <p>T-BARS ACVG65=2.5mm ACVG66=3.0mm ACVL150=4.0mm</p>  <p>Screw (Grub)</p>	<p>MF = Mill Finish SA = Silver Anodised KL = Basic Colour HP = Special Colour SSC = Smooth Satin Chrome SMC = Smokey Chrome PC = Polished Chrome</p>	<p>W = White Z = Black</p>																					

Image	Part Code	Pack	Unit	Application	Colour
	<b>ACMX09765</b> <b>Alu. Cleaner</b>	<b>1</b>	<b>each</b>		MF SA KL HP SSC SMC W Z PC
	<b>ACMX09770</b> <b>Roll &amp; Wrap 100mm</b>	<b>1</b>	<b>each</b>		MF SA KL HP SSC SMC W Z PC
	<b>ACMX09775</b> <b>Grip Handwrap</b>	<b>1</b>	<b>each</b>		MF SA KL HP SSC SMC W Z PC
	<b>ACMX09801</b> <b>Protective Tape 50mm</b>	<b>1</b>	<b>each</b>		MF SA KL HP SSC SMC W Z PC
	<b>ACMX09802</b> <b>Protective Tape 70mm</b>	<b>1</b>	<b>each</b>		MF SA KL HP SSC SMC W Z PC
 <p>T-BARS ACVG85=2.5mm ACVG66=3.0mm ACVL150=4.0mm</p>  <p>Screw (Grub)</p>	<b>MF = Mill Finish</b> <b>SA = Silver Anodised</b> <b>KL = Basic Colour</b> <b>HP = Special Colour</b> <b>SSC = Smooth Satin Chrome</b> <b>SMC = Smokey Chrome</b> <b>PC = Polished Chrome</b>	<b>W = White</b> <b>Z = Black</b>			

STANDARD ACCESSORIES





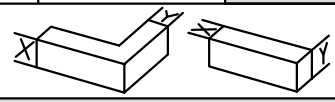

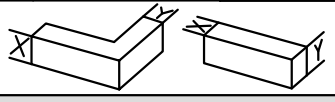

Image	Part Code	Pack	Unit	Application	Colour	
	<b>ACMX09803</b> <b>Protective Tape 100mm</b>	<b>1</b>	<b>each</b>		MF	
					SA	
					KL	
					HP	
					SSC	
					SMC	
					W	
					Z	
					PC	
	<b>ACMX09830</b> <b>Rubber Sealant</b>	<b>1</b>	<b>each</b>		MF	
					SA	
					KL	
					HP	
					SSC	
					SMC	
					W	
					Z	
					PC	
	<b>ACSIL04</b> <b>Sealing Glue</b> Order with suffix of KL colour (eg.ACSIL04KL005) or BL=Black/WP=White/ CL=Clear	<b>1</b>	<b>each</b>		MF	
					SA	
					KL	✓
					HP	
					SSC	
					SMC	
					W	✓
					Z	✓
					PC	
	<b>ACSIL08</b> <b>Silicon Gun</b>	<b>1</b>	<b>each</b>		MF	
					SA	
					KL	
					HP	
					SSC	
					SMC	
					W	
					Z	
					PC	
	<b>ACSIL013</b> <b>Glue for Mitre</b>	<b>1</b>	<b>each</b>		MF	
					SA	
					KL	
					HP	
					SSC	
					SMC	
					W	
					Z	
					PC	
 T-BARS ACVG65=2.5mm ACVG66=3.0mm ACVL150=4.0mm  Screw (Grub)	<b>MF = Mill Finish</b> <b>SA = Silver Anodised</b> <b>KL = Basic Colour</b> <b>HP = Special Colour</b> <b>SSC = Smooth Satin Chrome</b> <b>SMC = Smokey Chrome</b> <b>PC = Polished Chrome</b>	<b>W = White</b> <b>Z = Black</b>				

Image	Part Code	Pack	Unit	Application	Colour
	<b>ACSIL014</b>  <b>Anti-Corrosion Coating</b>	<b>1</b>	<b>each</b>		MF <input checked="" type="checkbox"/>
					SA <input type="checkbox"/>
					KL <input type="checkbox"/>
					HP <input type="checkbox"/>
					SSC <input type="checkbox"/>
					SMC <input type="checkbox"/>
					W <input type="checkbox"/>
					Z <input type="checkbox"/>
					PC <input type="checkbox"/>
					
SA <input type="checkbox"/>					
KL <input type="checkbox"/>					
HP <input type="checkbox"/>					
SSC <input type="checkbox"/>					
SMC <input type="checkbox"/>					
W <input type="checkbox"/>					
Z <input type="checkbox"/>					
PC <input type="checkbox"/>					
					SA <input type="checkbox"/>
					KL <input type="checkbox"/>
					HP <input type="checkbox"/>
					SSC <input type="checkbox"/>
					SMC <input type="checkbox"/>
					W <input type="checkbox"/>
					Z <input type="checkbox"/>
					PC <input type="checkbox"/>
SA <input type="checkbox"/>					
KL <input type="checkbox"/>					
HP <input type="checkbox"/>					
SSC <input type="checkbox"/>					
SMC <input type="checkbox"/>					
W <input type="checkbox"/>					
Z <input type="checkbox"/>					
PC <input type="checkbox"/>					
 <p>T-BARS ACVG65=2.5mm ACVG66=3.0mm ACVL150=4.0mm</p>  <p>Screw (Grub)</p>	<b>MF = Mill Finish</b> <b>SA = Silver Anodised</b> <b>KL = Basic Colour</b> <b>HP = Special Colour</b> <b>SSC = Smooth Satin Chrome</b> <b>SMC = Smokey Chrome</b> <b>PC = Polished Chrome</b>				
					Z = Black
					

# Visotherm Tilt & Turn Window

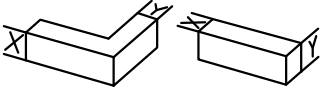

## Section C

Sections  
Scale Elevations

# Visotherm Tilt & Turn Window

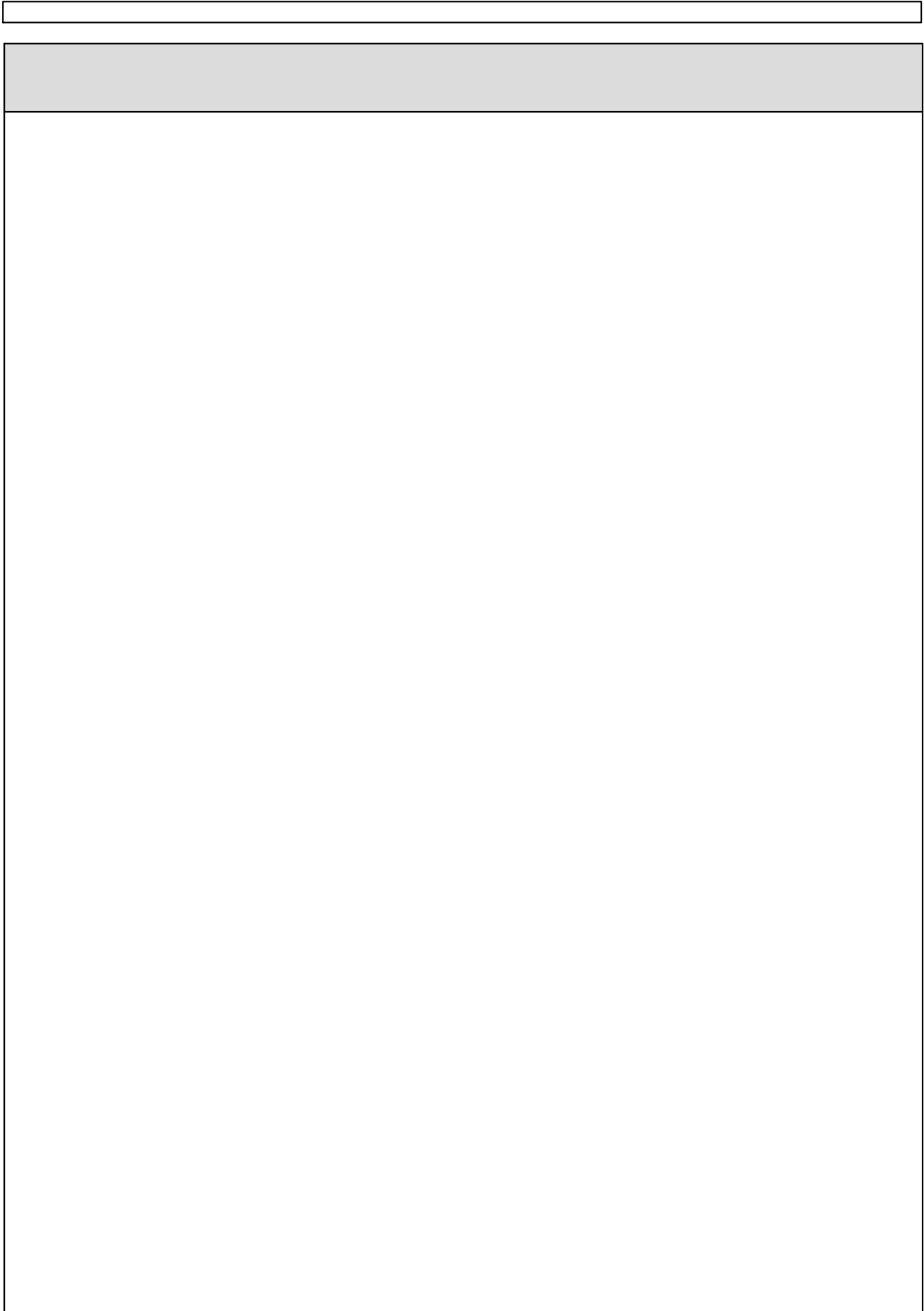

## Detail

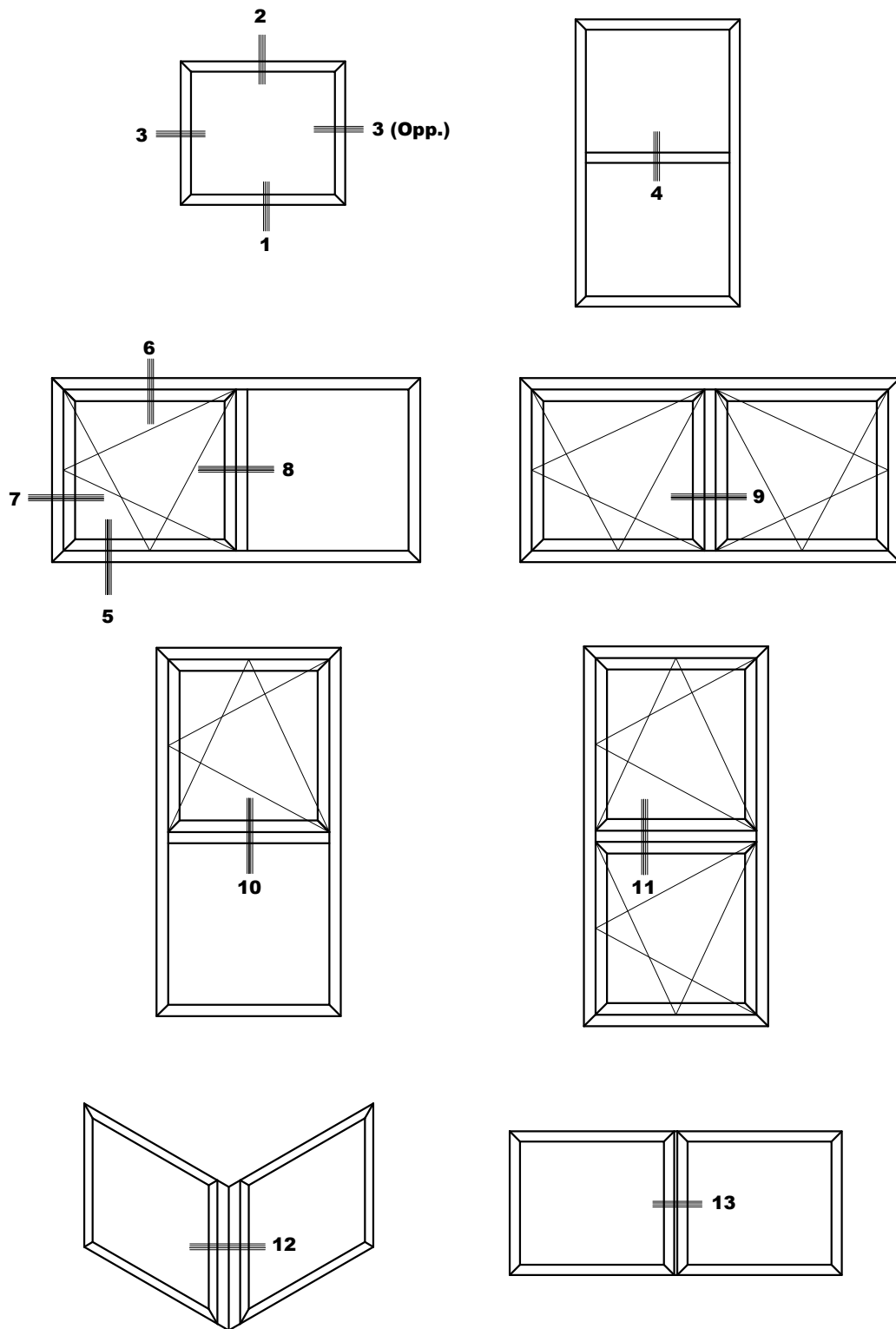

**Do Not Scale From This Drawing**

## Detail 1A

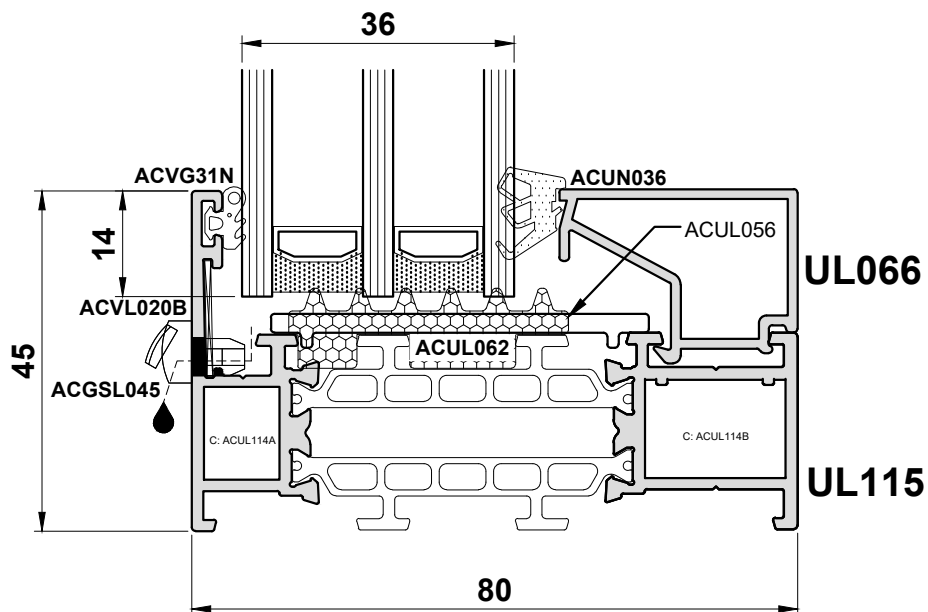
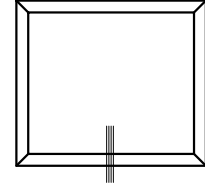

Do Not Scale From This Drawing



## Detail 1B

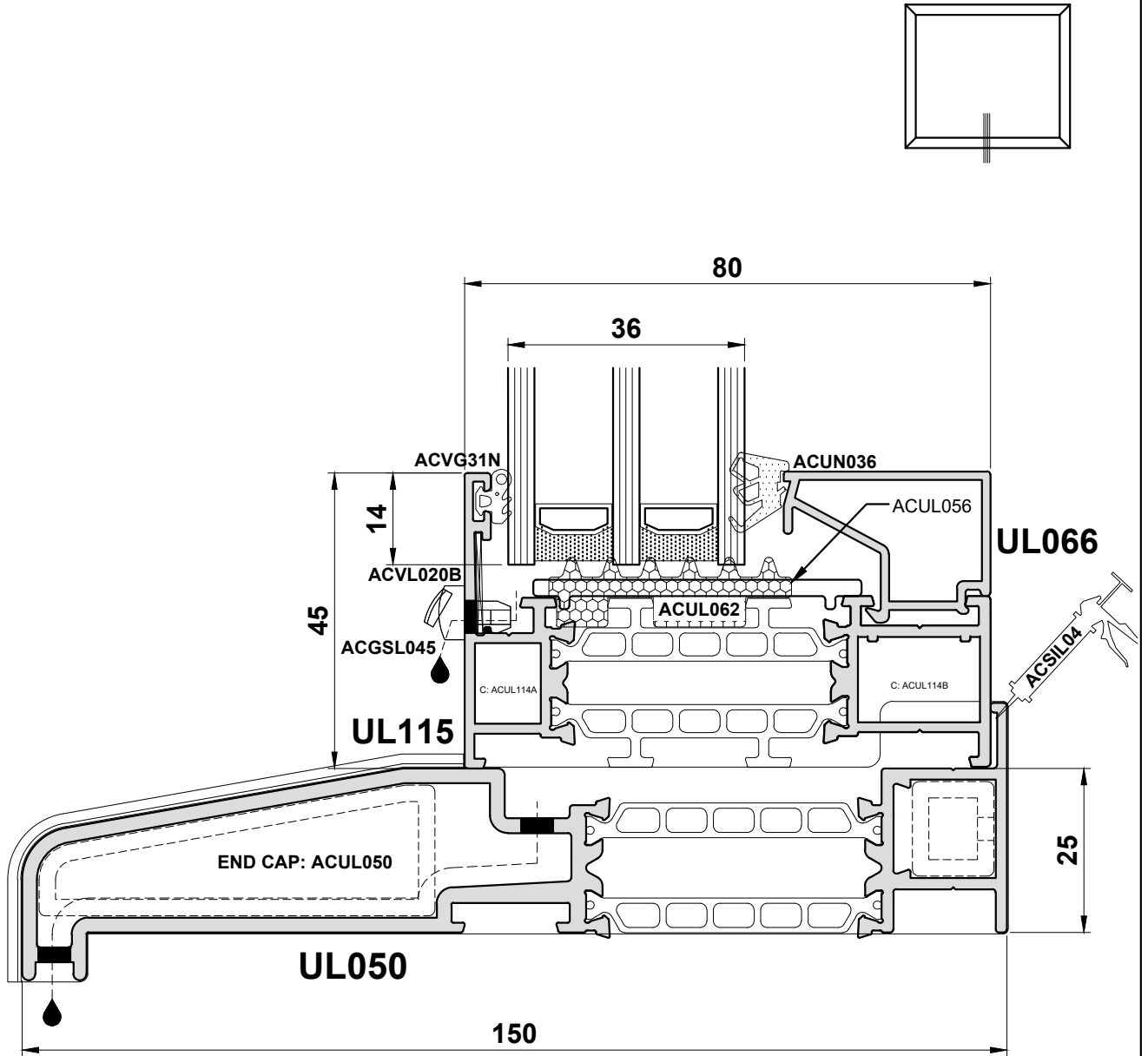

Do Not Scale From This Drawing

Detail 2

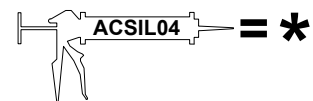
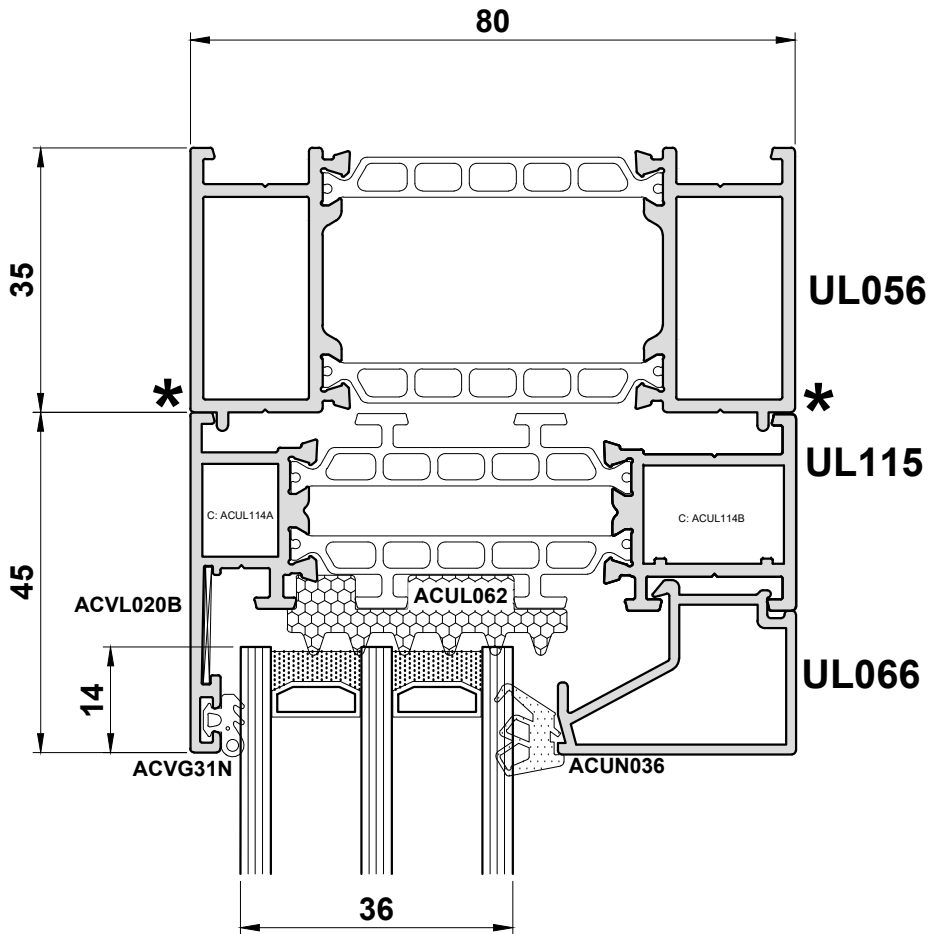
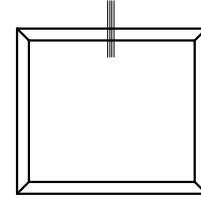

Do Not Scale From This Drawing

## Detail 3A

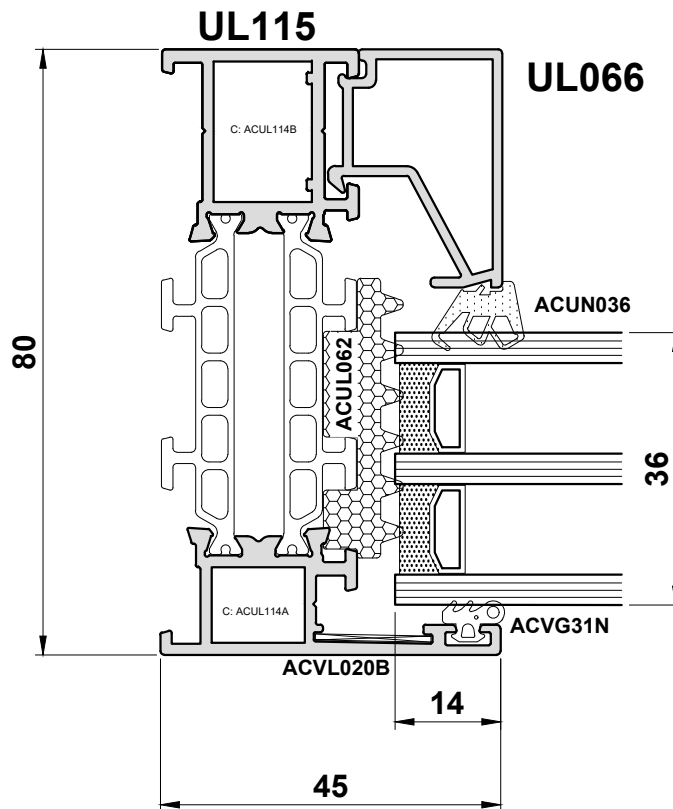
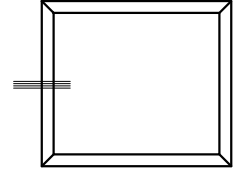

**Do Not Scale From This Drawing**

## Detail 3B

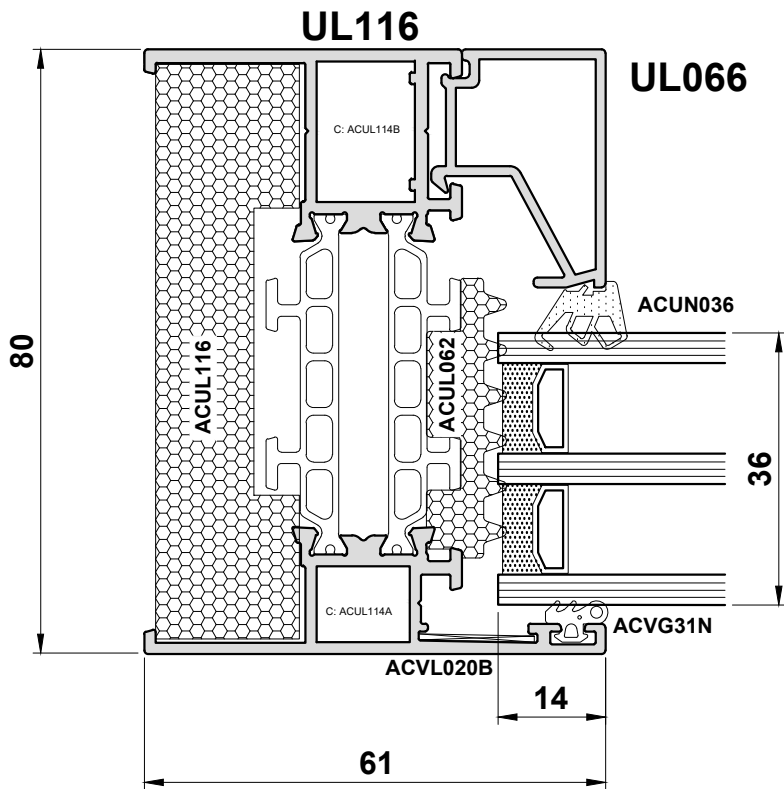
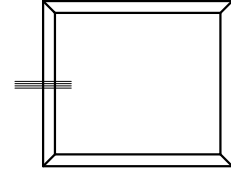

Do Not Scale From This Drawing

## Detail 4A

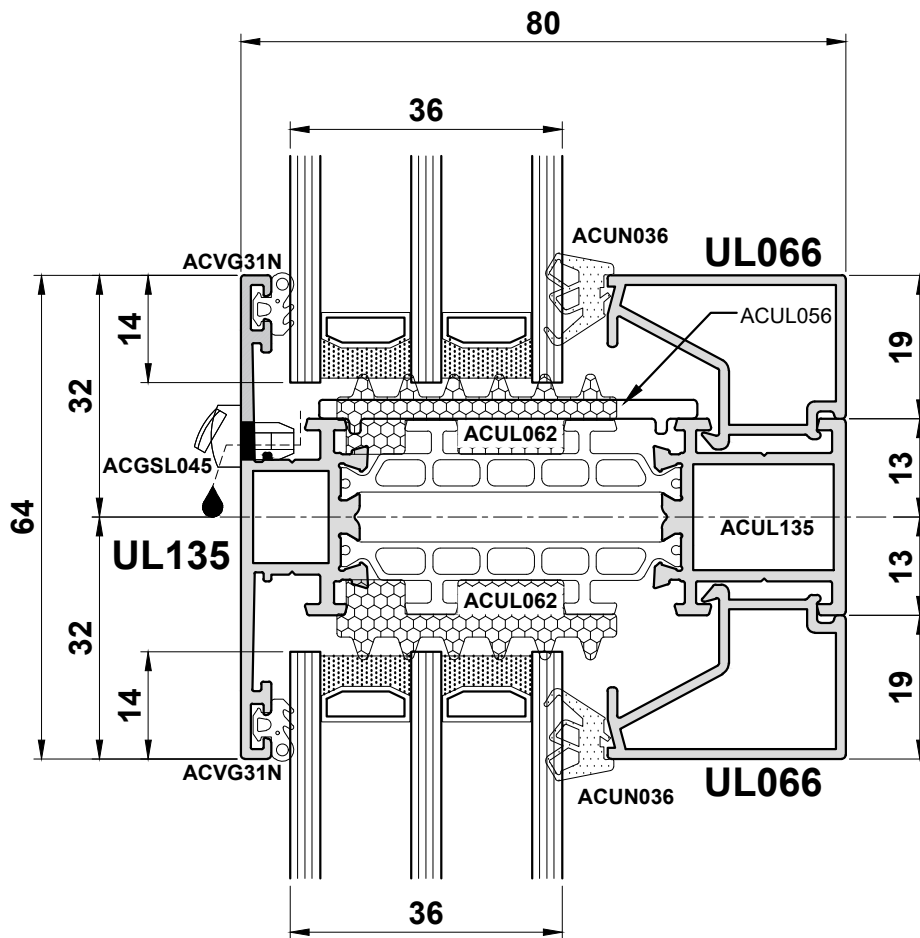

Do Not Scale From This Drawing

Detail 4B

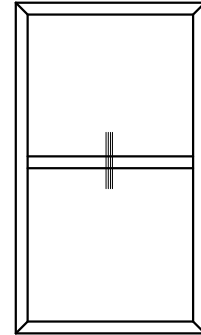
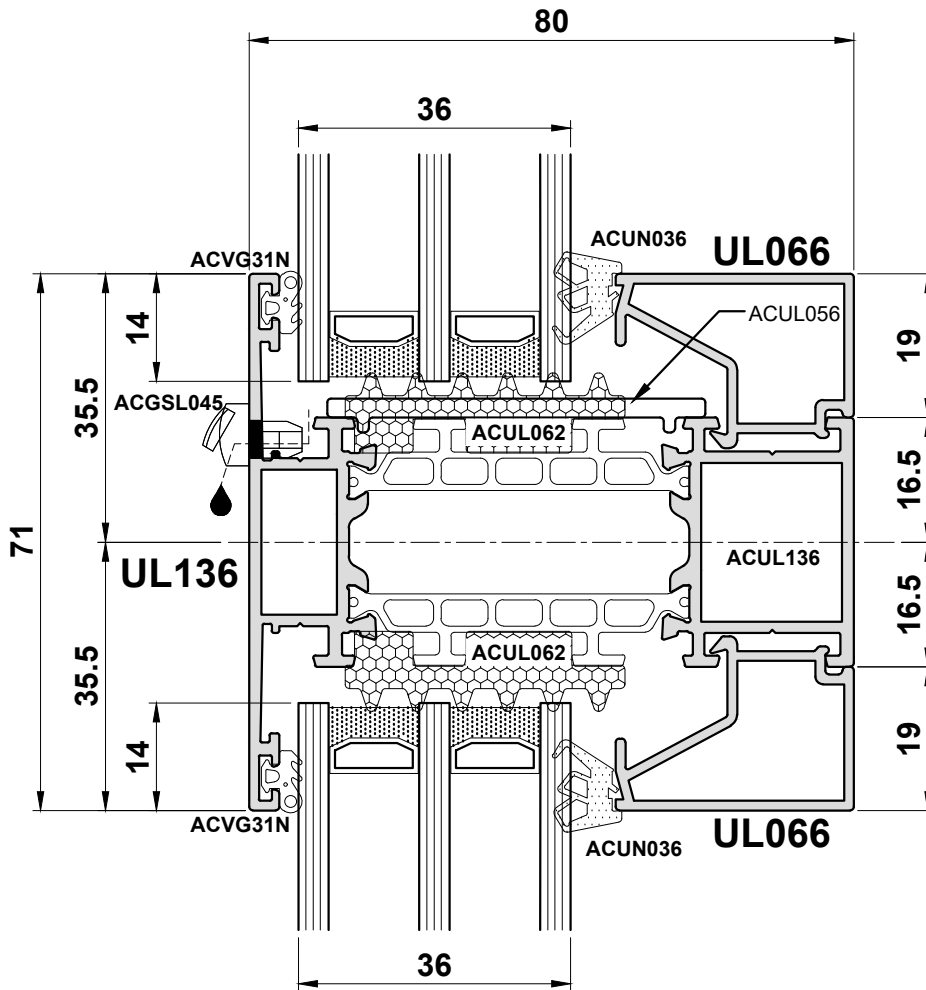

Do Not Scale From This Drawing

**Detail 5A**

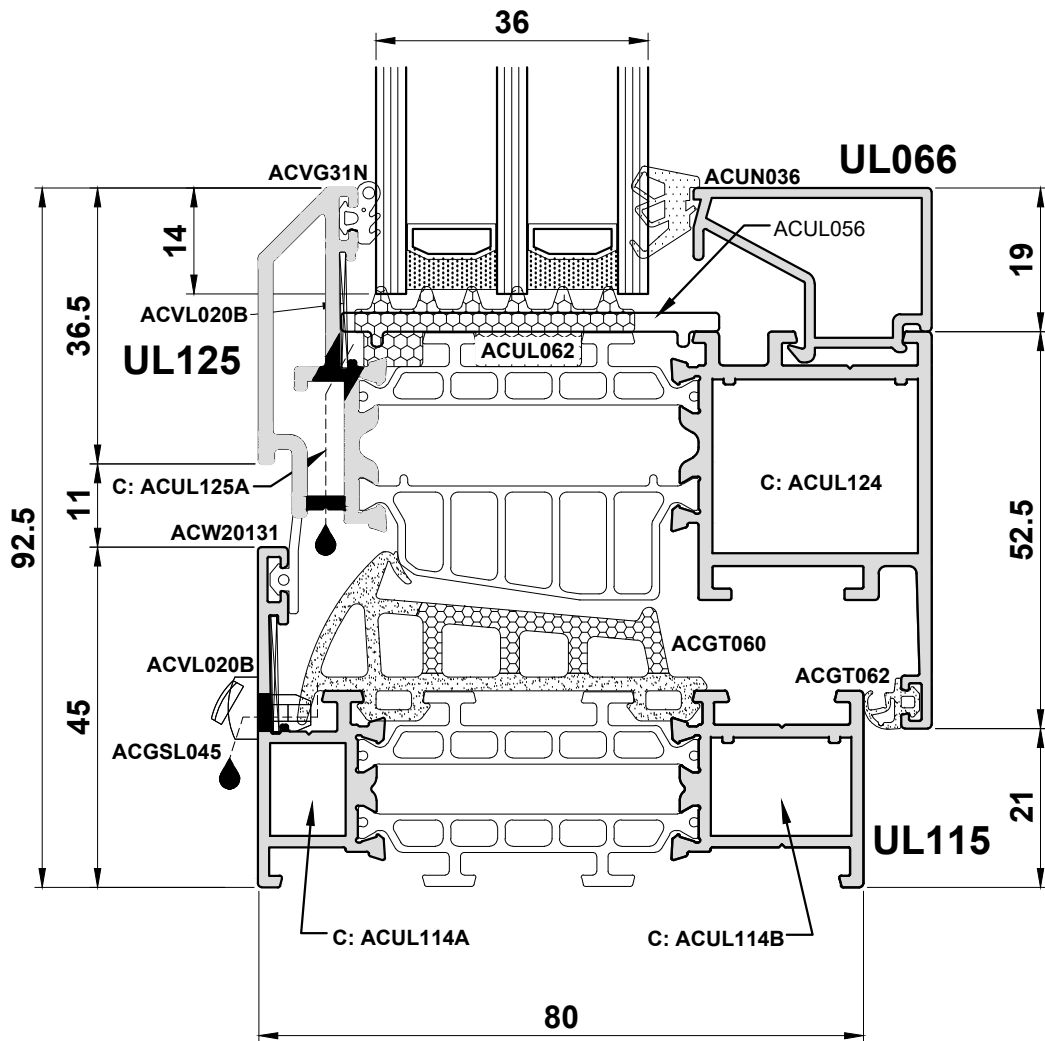
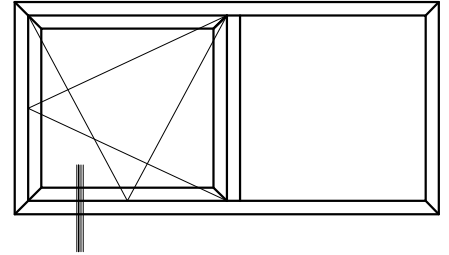

**Do Not Scale From This Drawing**

**Detail 5B**

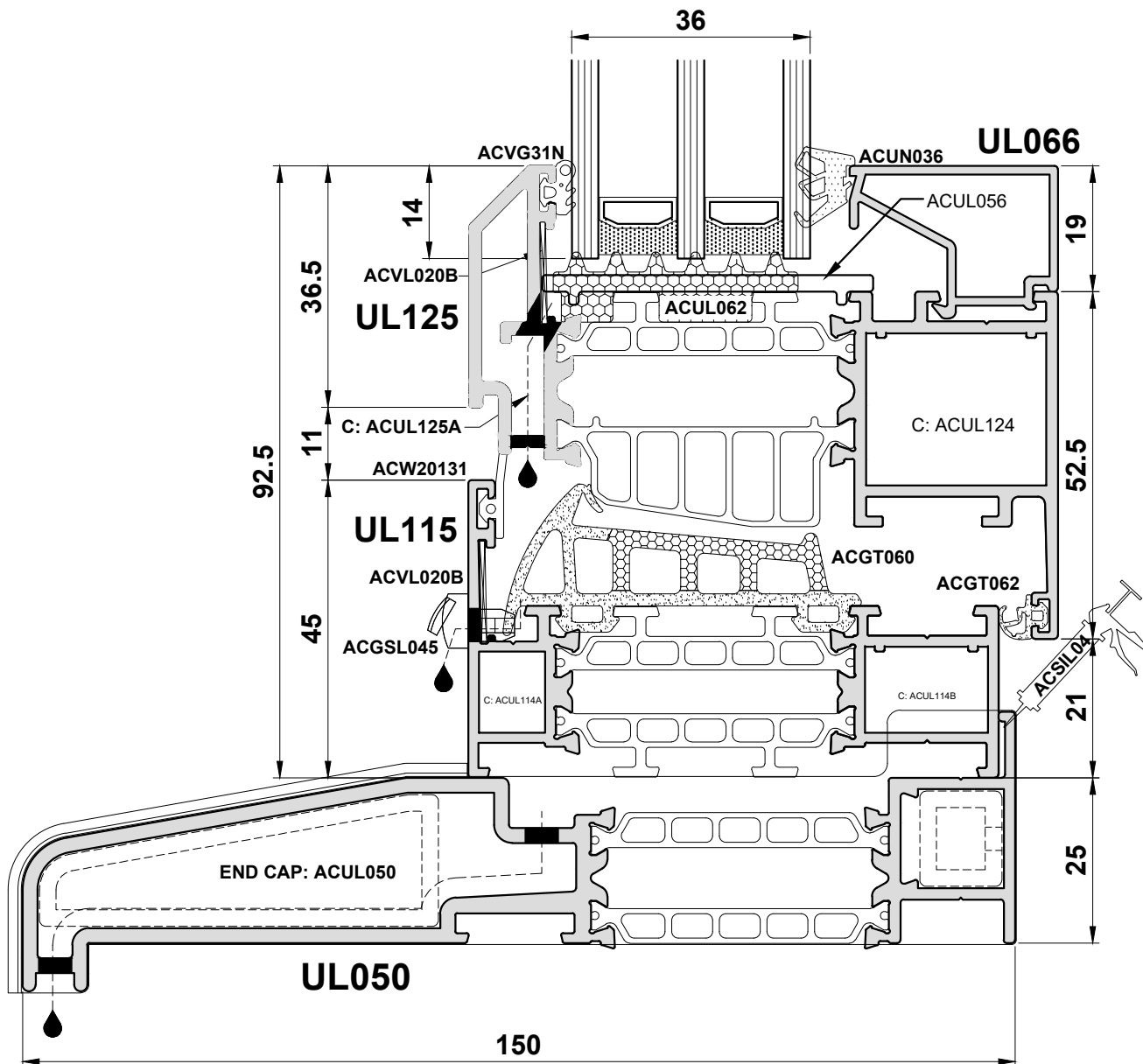
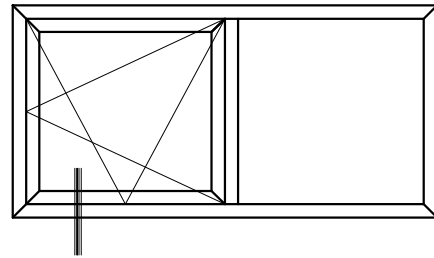

**Do Not Scale From This Drawing**



Detail 6A

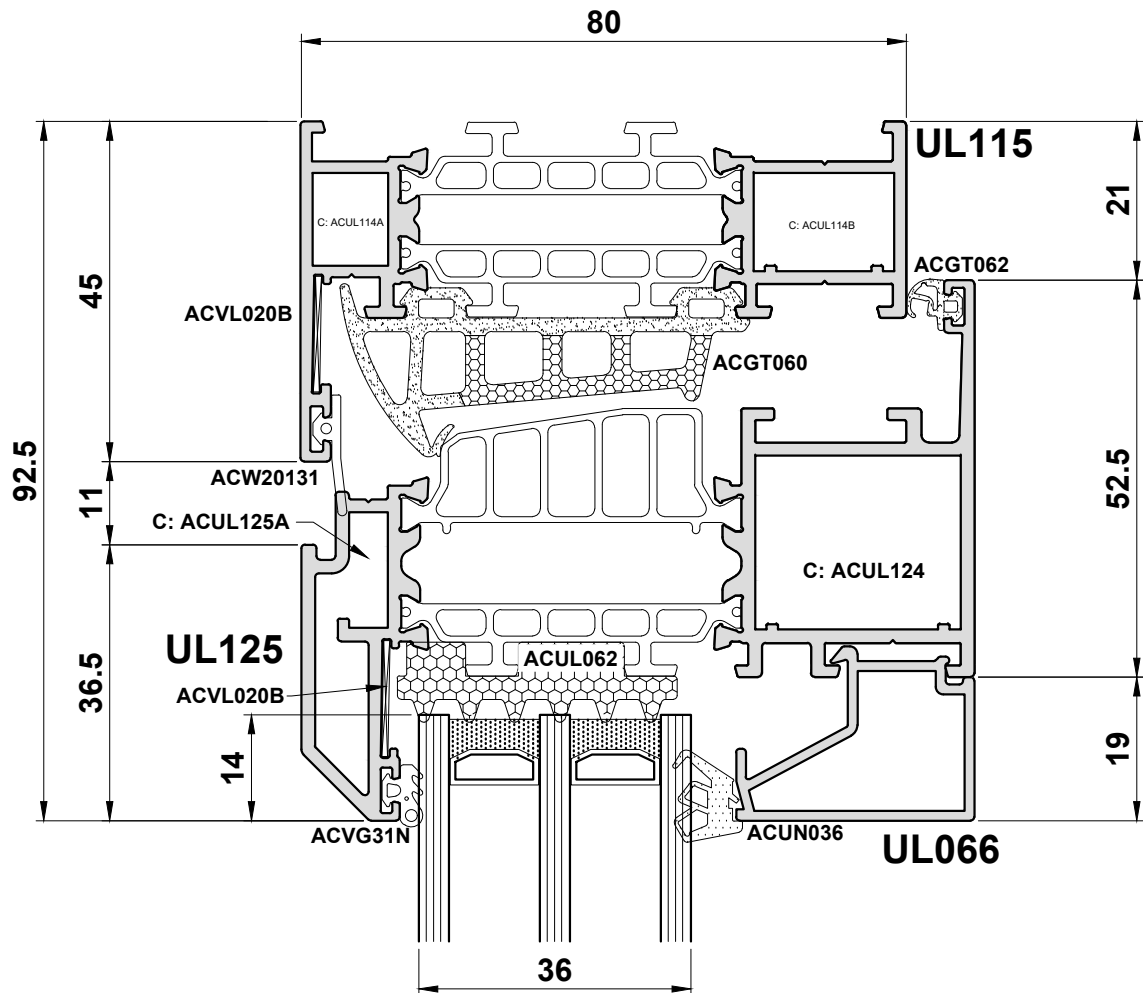
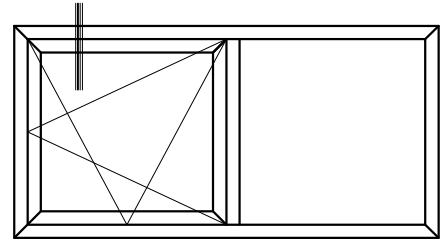

Do Not Scale From This Drawing

**Detail 6B**

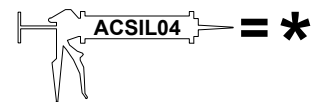
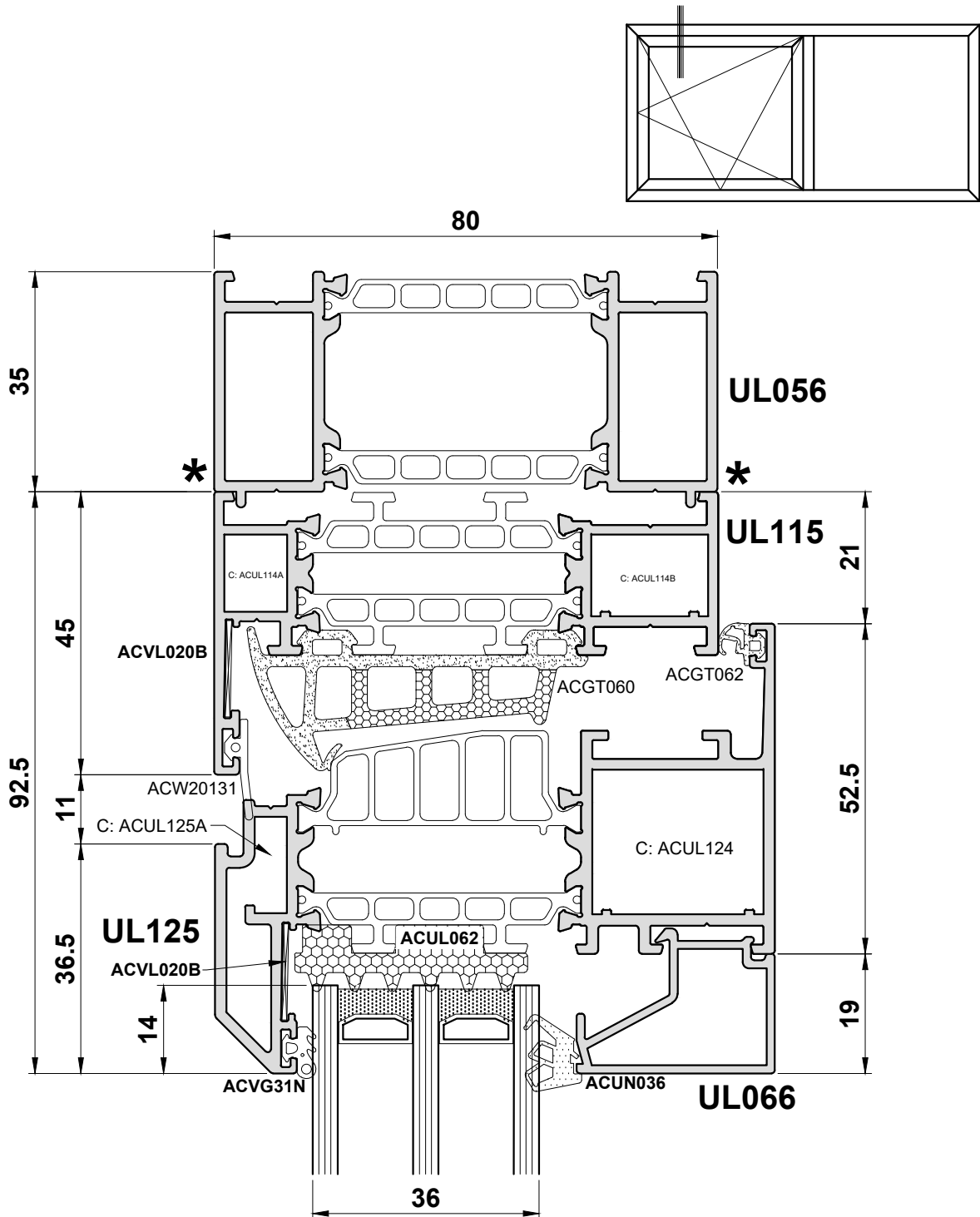

**Do Not Scale From This Drawing**

**Detail 7A**

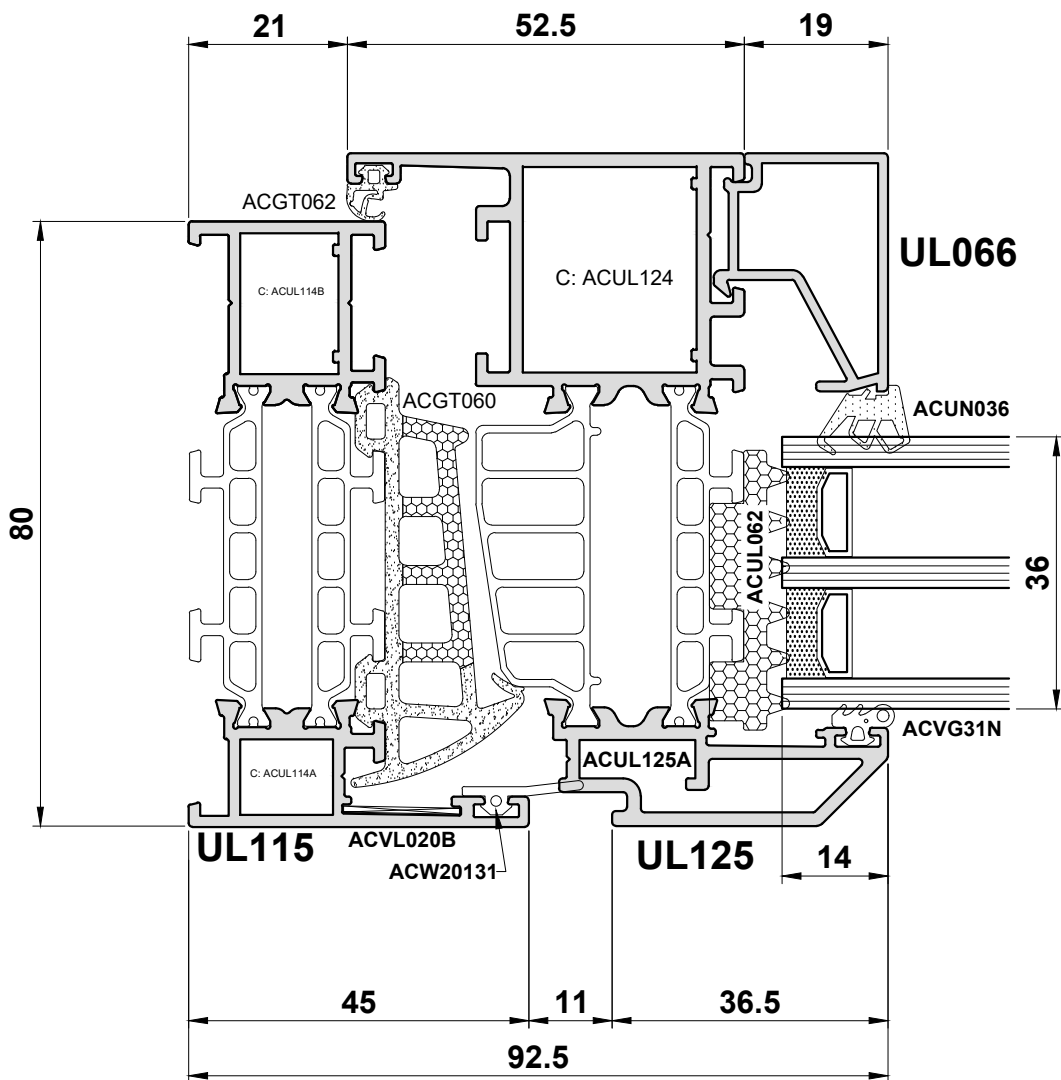
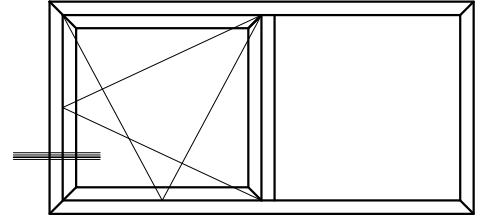

**Do Not Scale From This Drawing**

**Detail 7B**

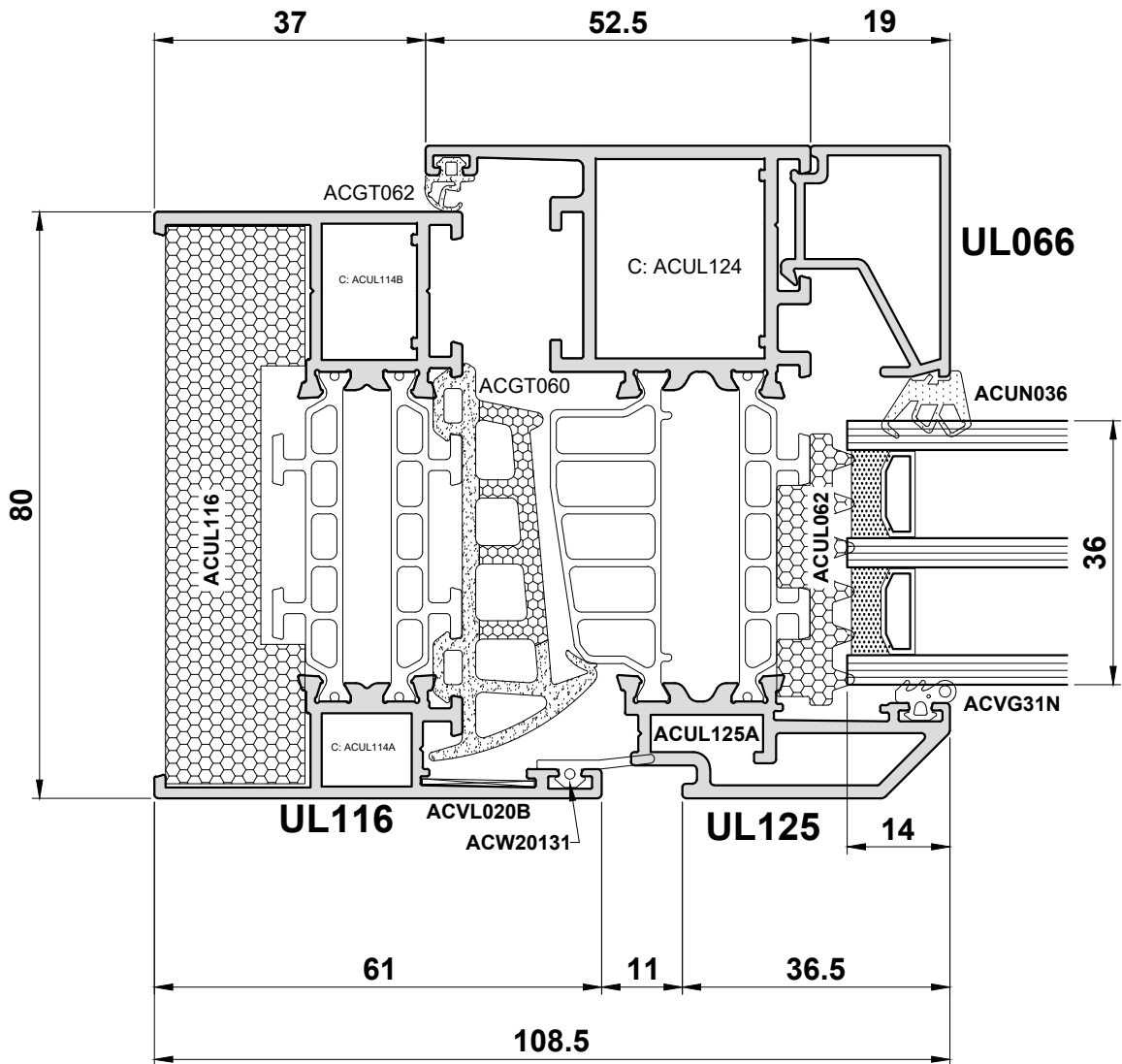
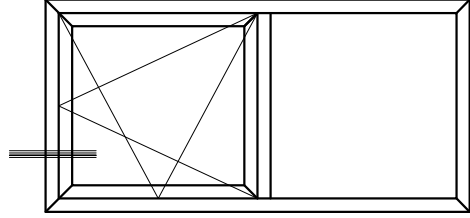

**Do Not Scale From This Drawing**

Detail 8

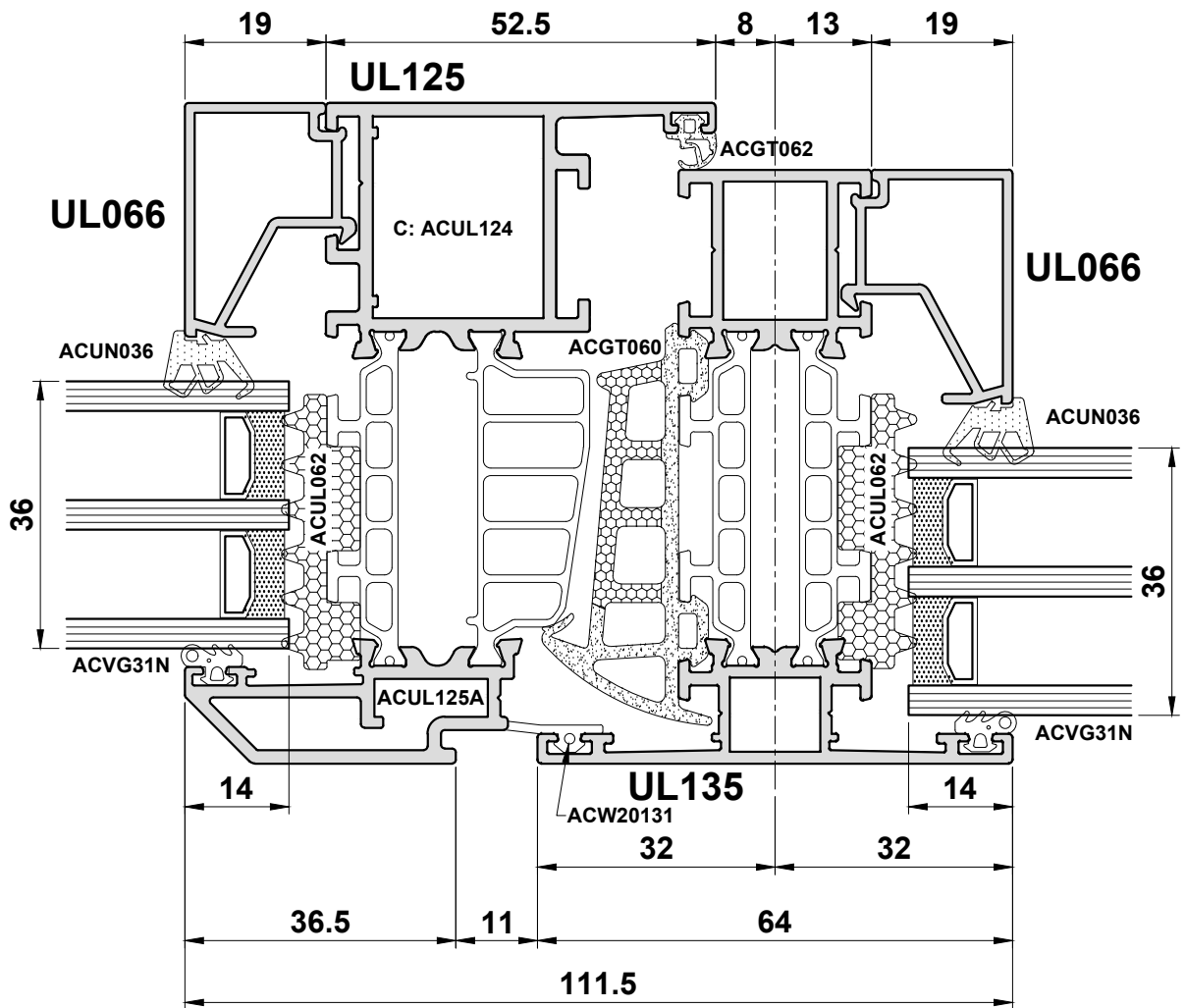
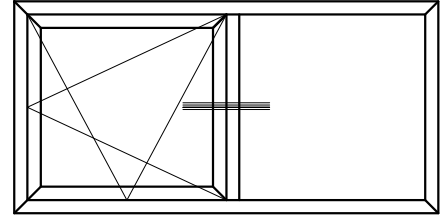

Do Not Scale From This Drawing

Detail 9

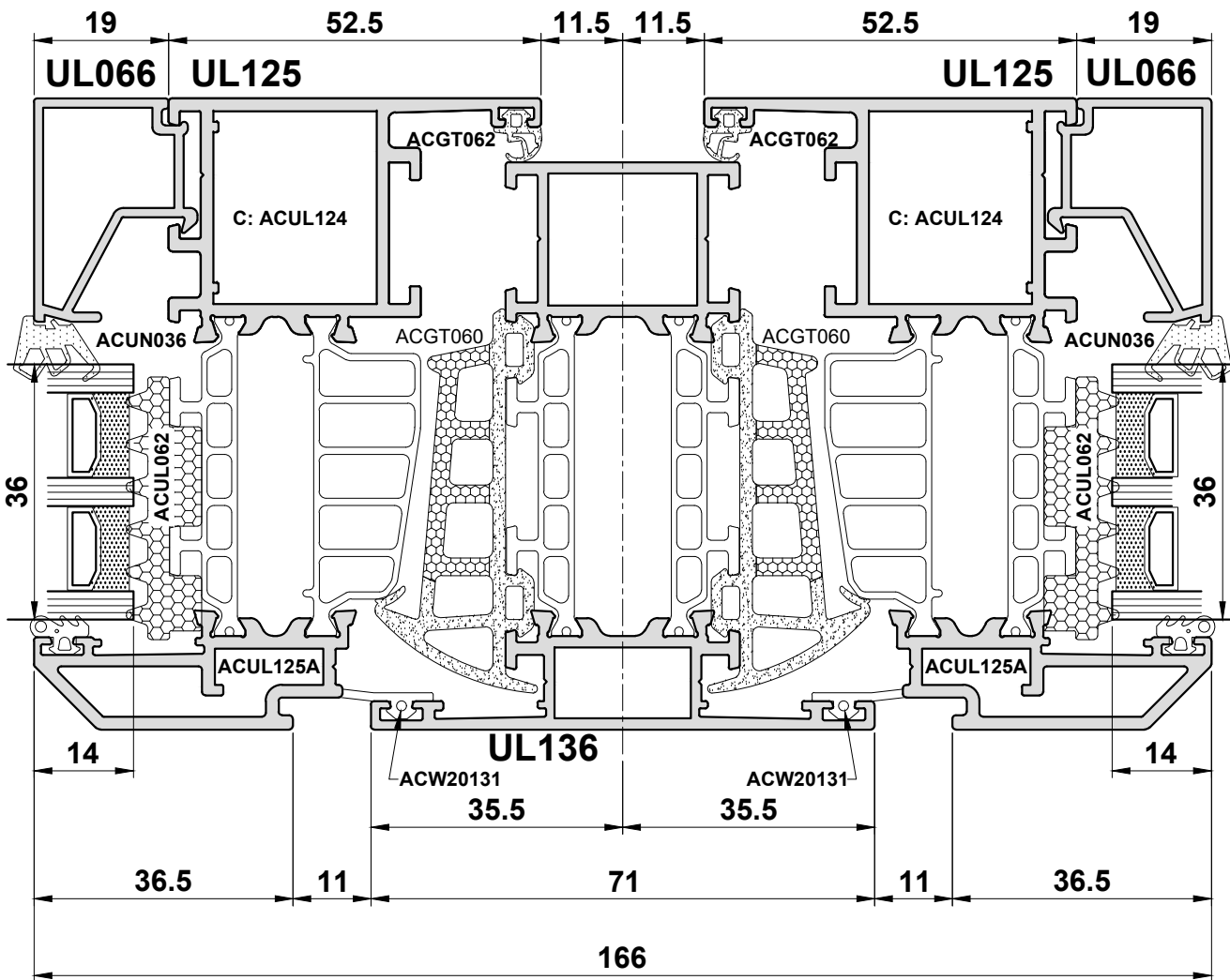
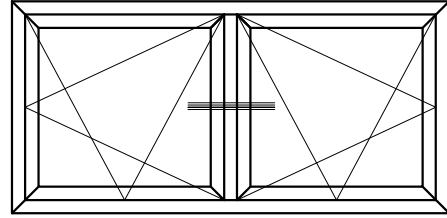

Do Not Scale From This Drawing

Detail 10

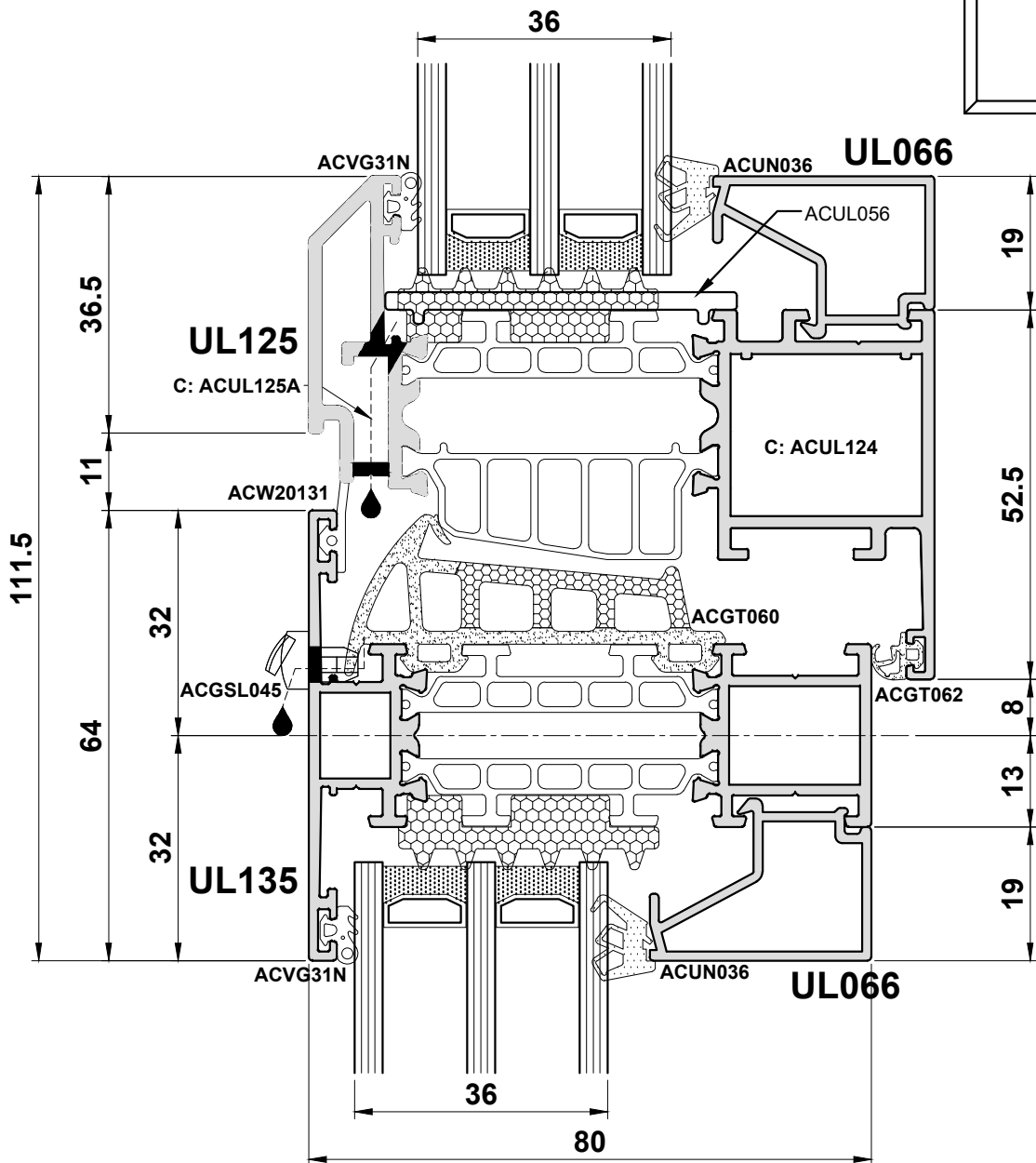

Do Not Scale From This Drawing

**Detail 11**

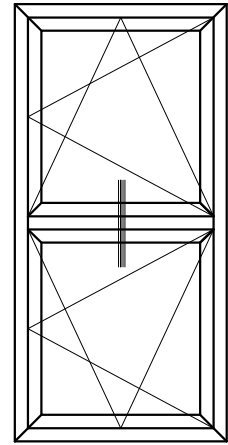
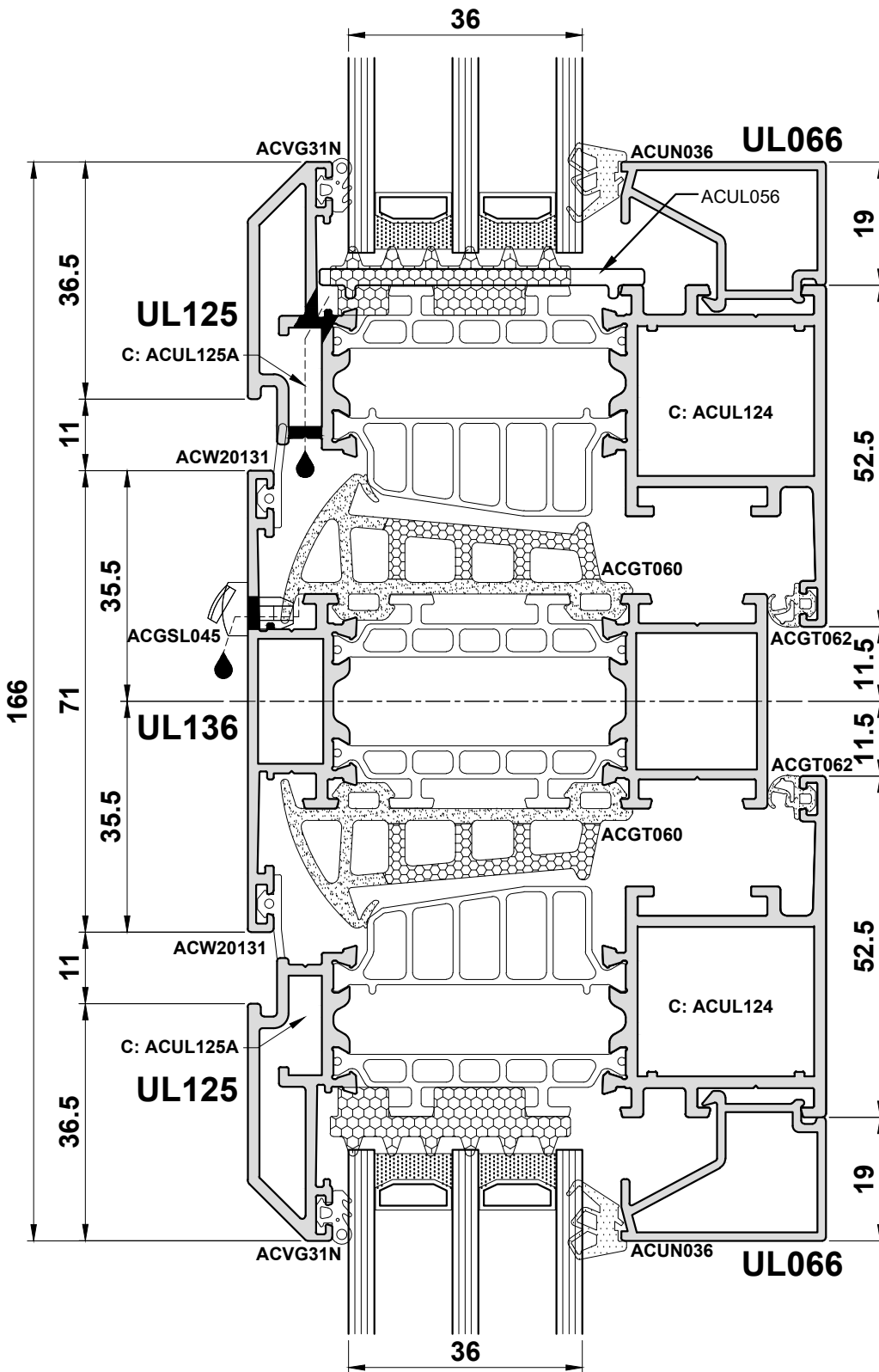

**Do Not Scale From This Drawing**



Detail 12

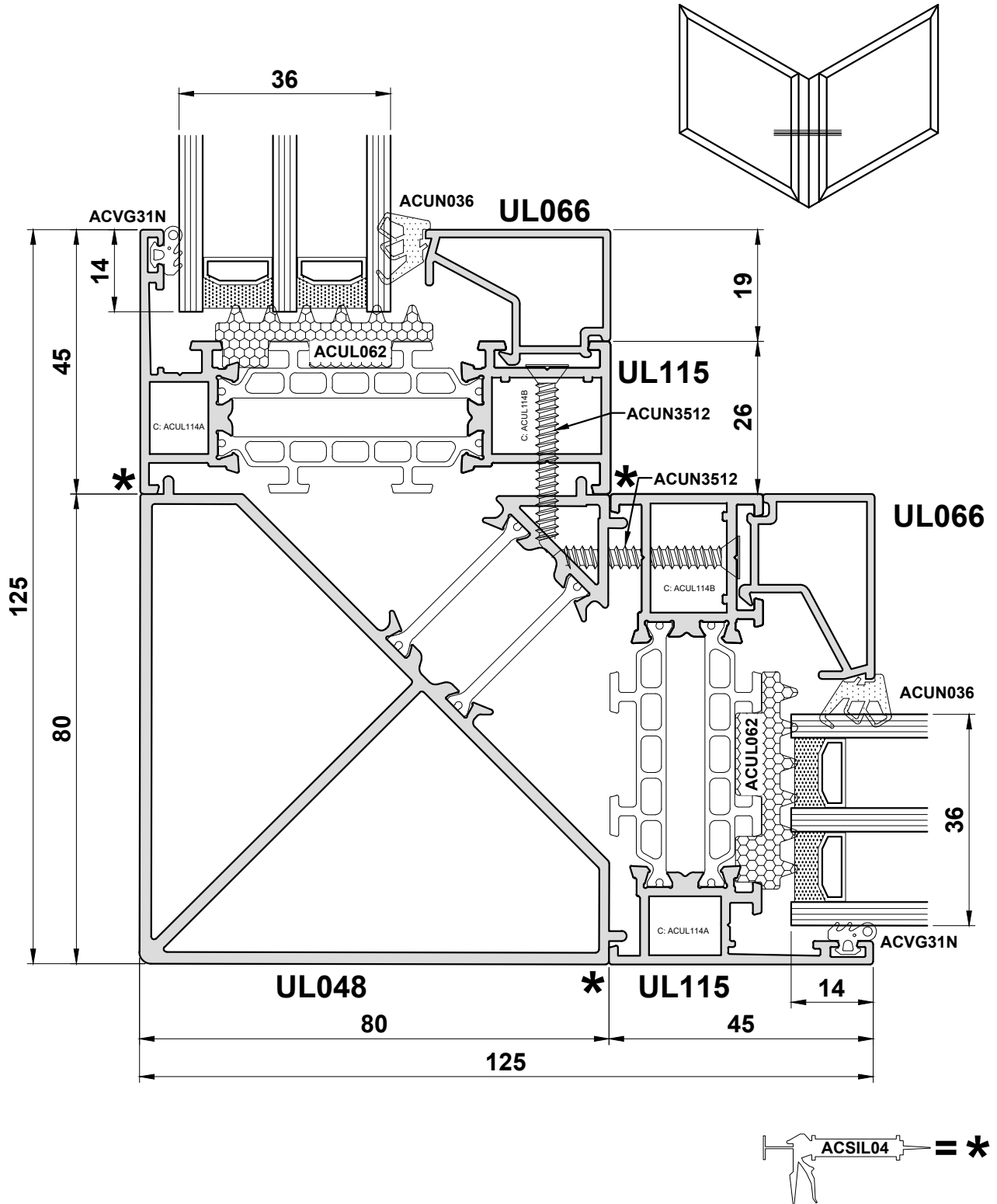

Do Not Scale From This Drawing

Detail 13

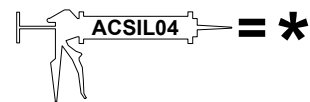
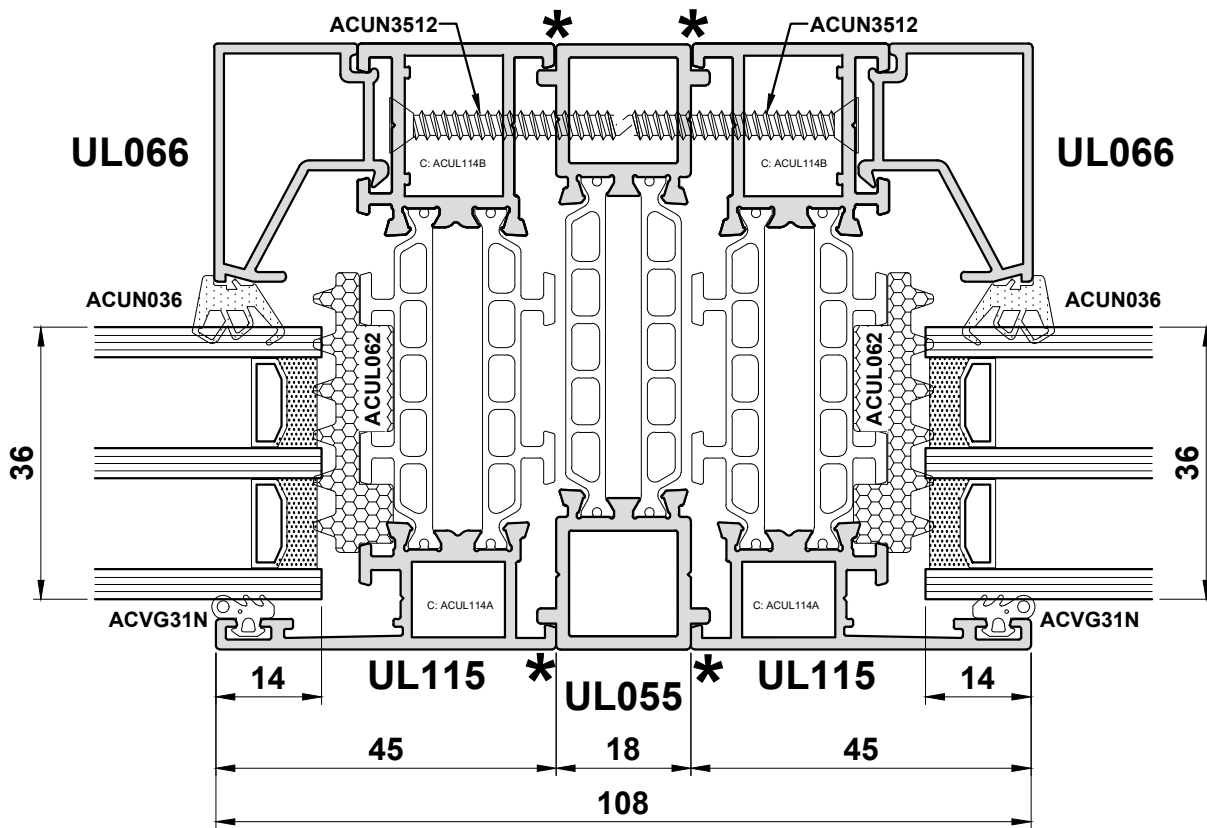
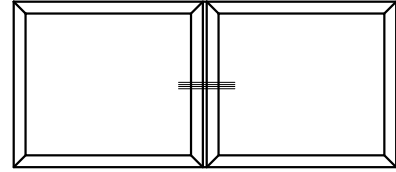

Do Not Scale From This Drawing

**Section D**

**Statics**

**Tilt & Turn**

**General Size Limitations are shown in section A.  
Please also consider maximum limits of accessories.**

**For Wind Loading Limitations, Please Contact  
The Technical Department - T: 01934 833100**

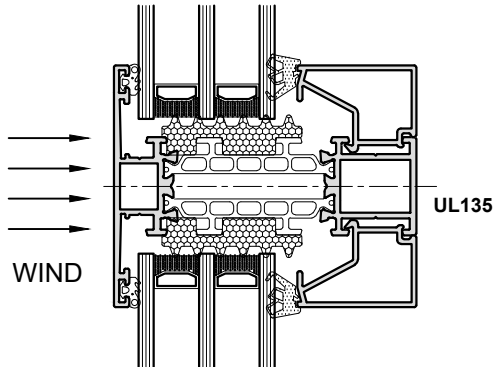

The position of the axes is an indication for the use and application of the moments of inertia ( $I_x$  and  $I_y$ ) and the section modulus ( $W_x$  and  $W_y$ ). We always choose the values of the axis perpendicular to the load to resist it.

- To resist the wind loads we use the values  $I_x$  and  $W_x$ .

**EXAMPLE**

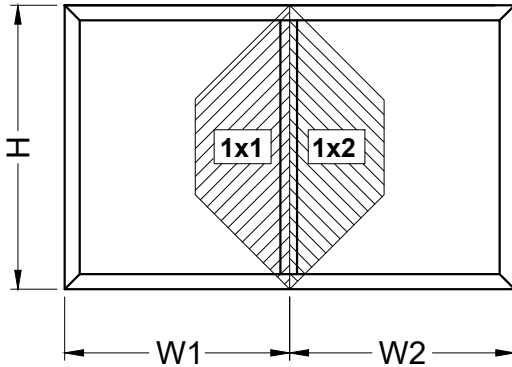

$H = 175\text{cm}$

$W1 = 120\text{cm}$

$W2 = 100\text{cm}$

$P = 1250\text{ Pa}$  (wind pressure)

- 1) Determine  $I_{xx}$  value for the stiles (if required) using the Specification Wizard

**$I_{xx} = 21.0\text{ cm}^4$**

- 2) Determine suitability

**OK**

Number	Picture	$I_x(\text{cm}^4)$ $w_x(\text{cm}^3)$	$I_y(\text{cm}^4)$ $w_y(\text{cm}^3)$
<b>UL135</b>		<b>40.68</b>	6.66
		8.56	2.08
<b>UL136</b>		47.68	10.88
		10.74	3.06

**Section E**



**Construction Drawings**

Corner Joint Details.....	E03
Corner Crimping.....	E04
Cill Drainage.....	E05
Window Drainage.....	E06
Tilt & Turn Outer Frame & Sash.....	E07-E08
Tilt & Turn Overview.....	E09
ACUN3140.....	E10
Mullion/Transom Detail	E11
Glazing Chart.....	E12

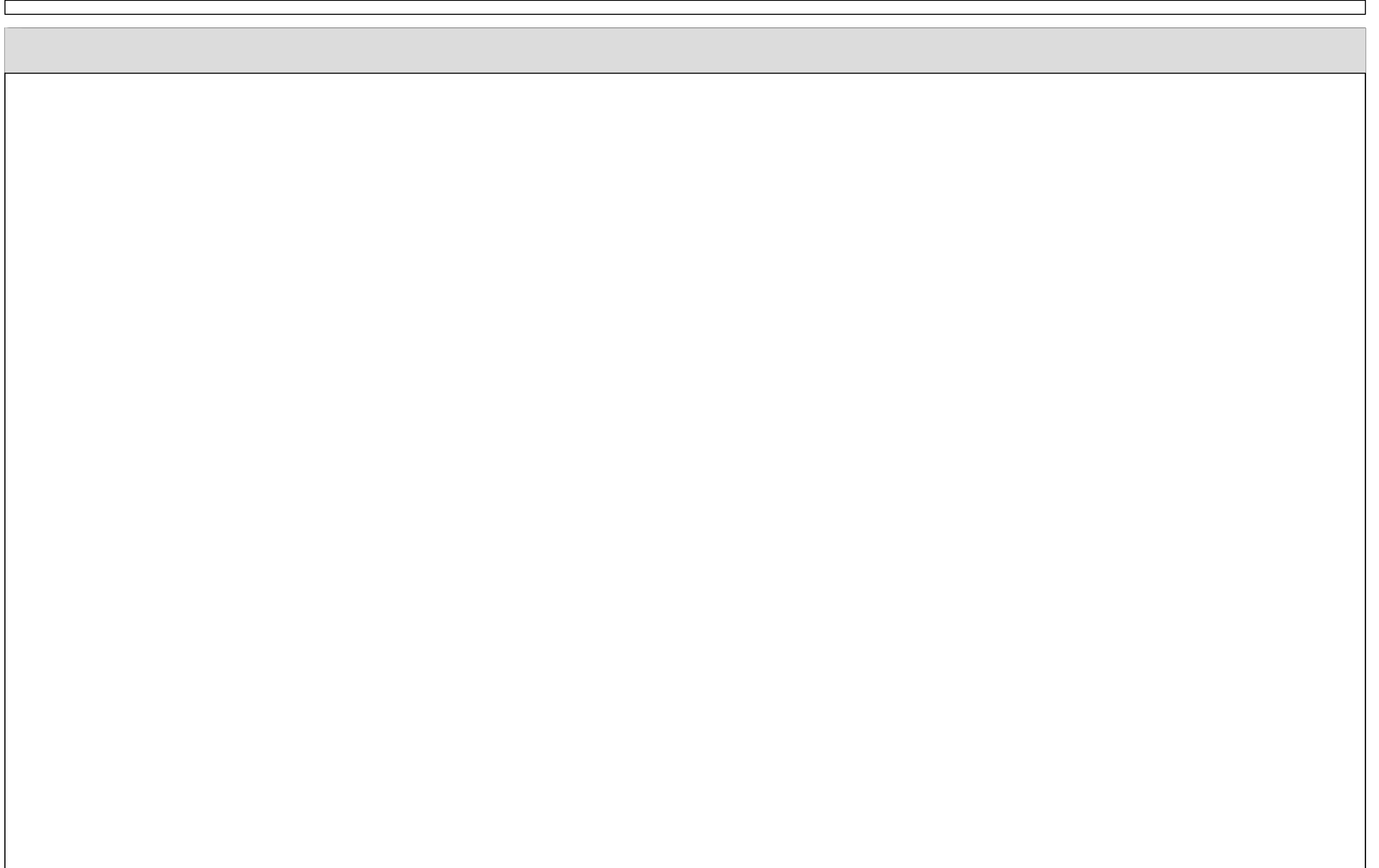

**Corner Joint Details**

**Notes**

1. Degrease mitre sections
2. Cover mitred faces with ACSIL04
3. Apply ACSIL013 to cleat chamber
4. Apply ACSIL04 to any fractures formed by crimping to make watertight

**Table 1**

KL Colour	Sealant Part Number
Black	ACSIL04BL
White	ACSIL04WP
Clear	ACSIL04CL
KL001	ACSIL04KL001
KL002	ACSIL04KL002
KL003	ACSIL04KL003
KL004	ACSIL04KL004
KL005	ACSIL04KL005
KL006	ACSIL04KL006
KL007	ACSIL04KL007
KL010	ACSIL04KL010
KL011	ACSIL04KL011
KL012	ACSIL04KL012
KL013	ACSIL04KL013

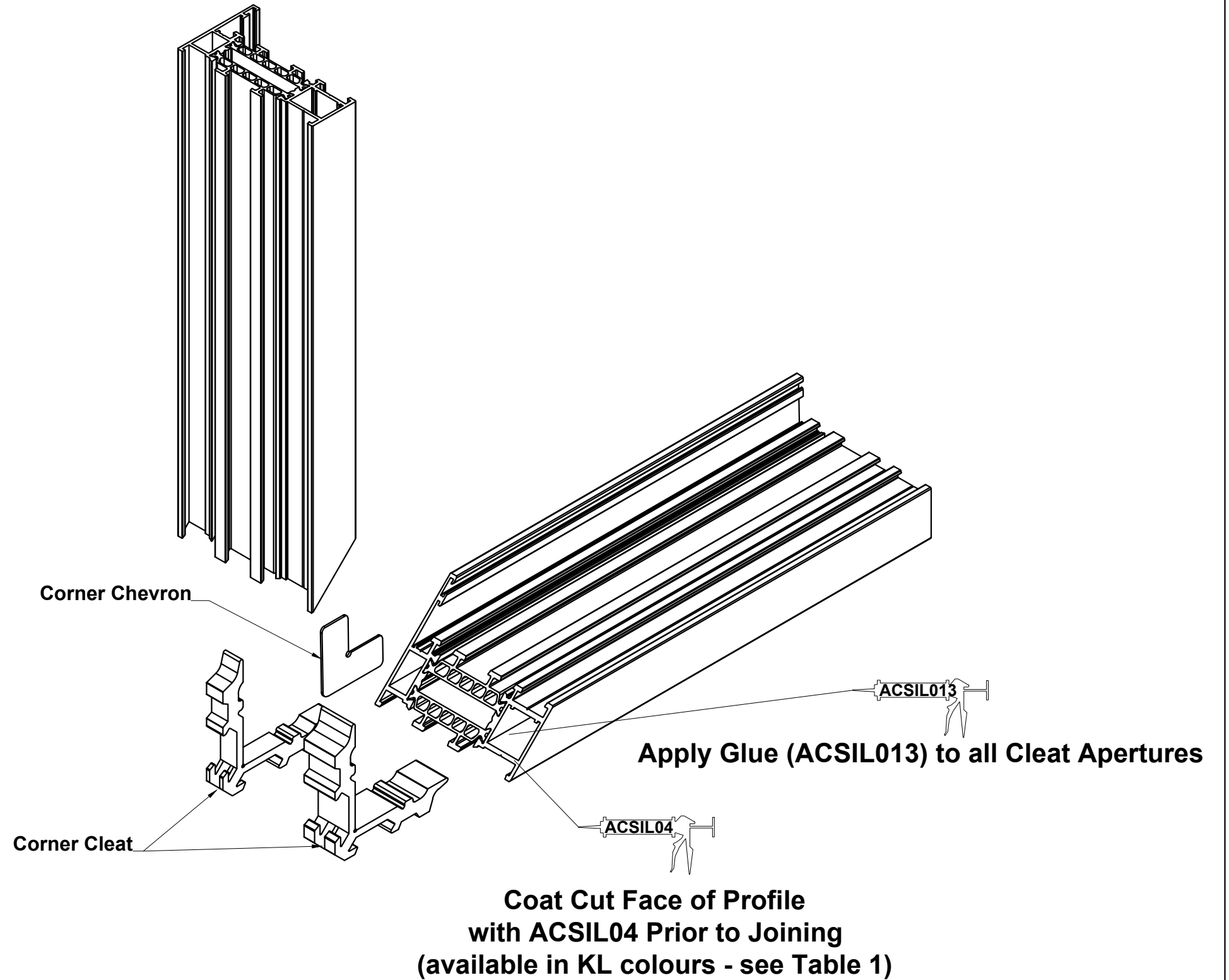

Do Not Scale From This Drawing

Corner Crimping

Manual Crimper = WUT024HSZA

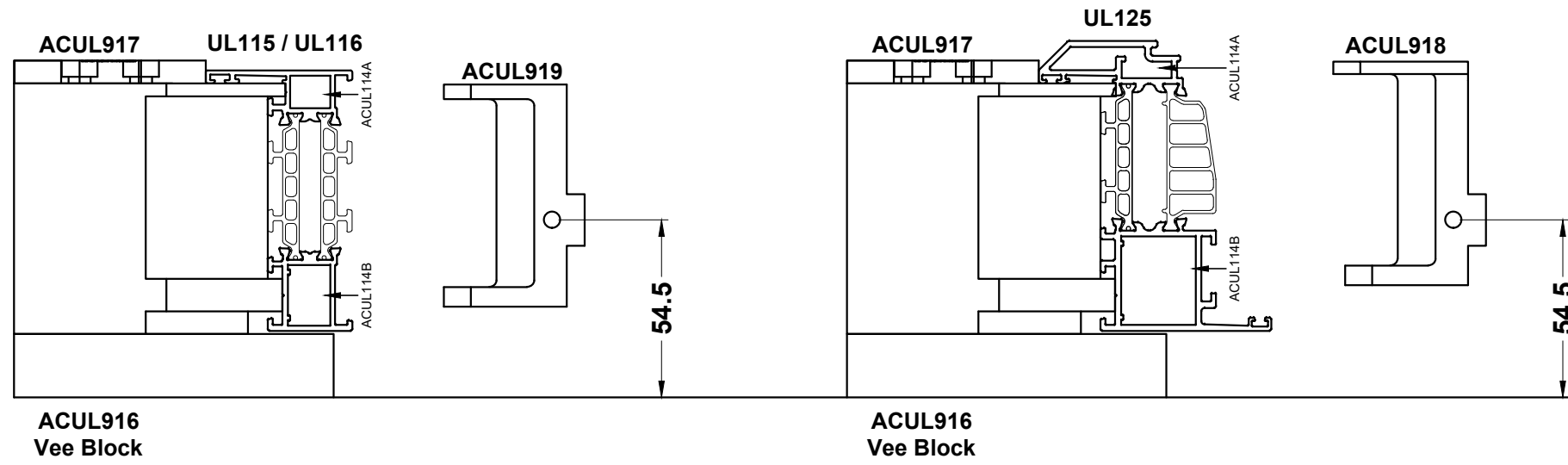

Do Not Scale From This Drawing



**Cill Drainage**

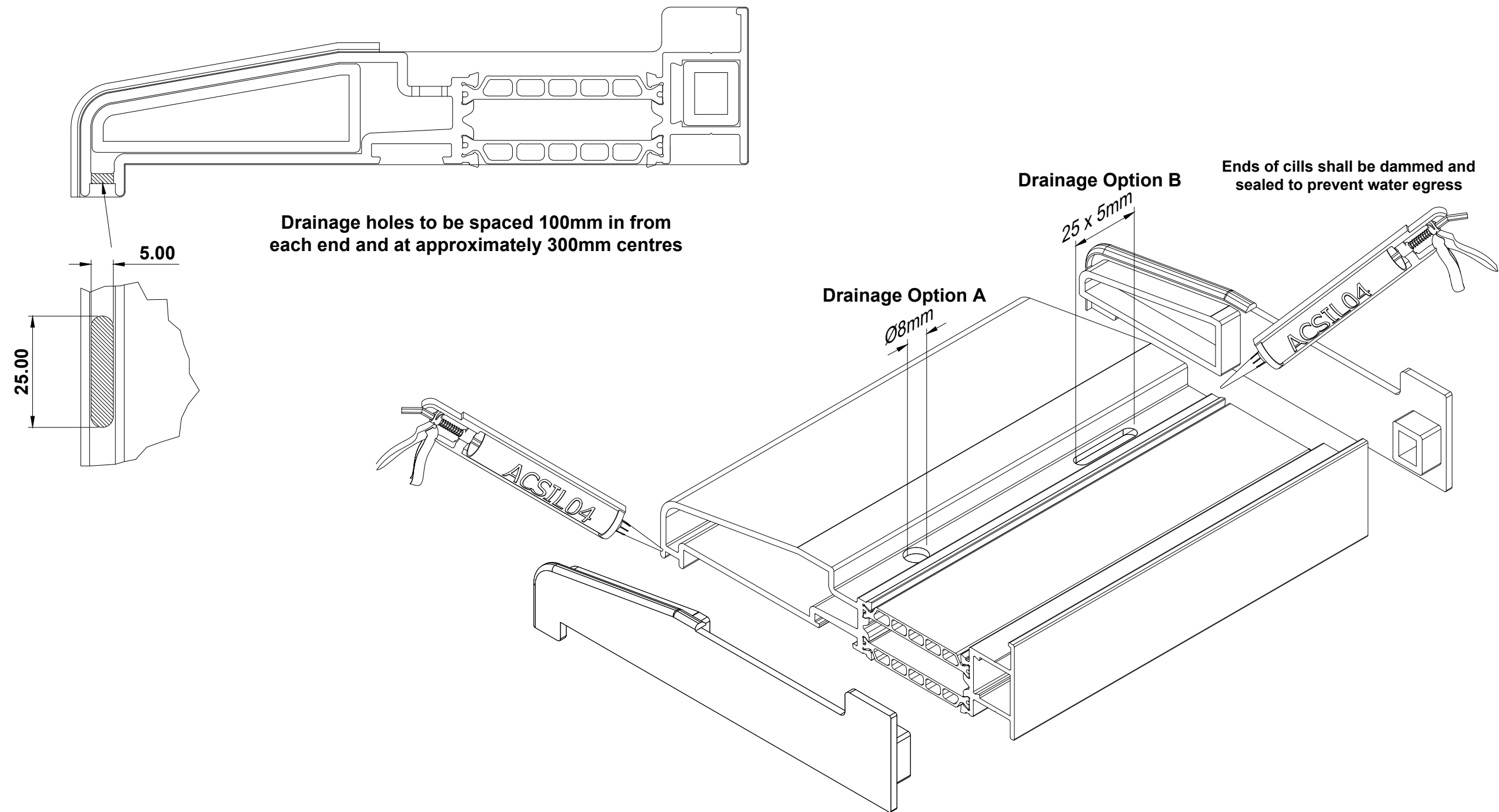

**Do Not Scale From This Drawing**

Window Drainage

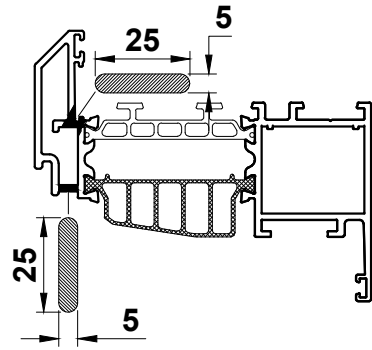

**A.**  
**Sash Drainage**

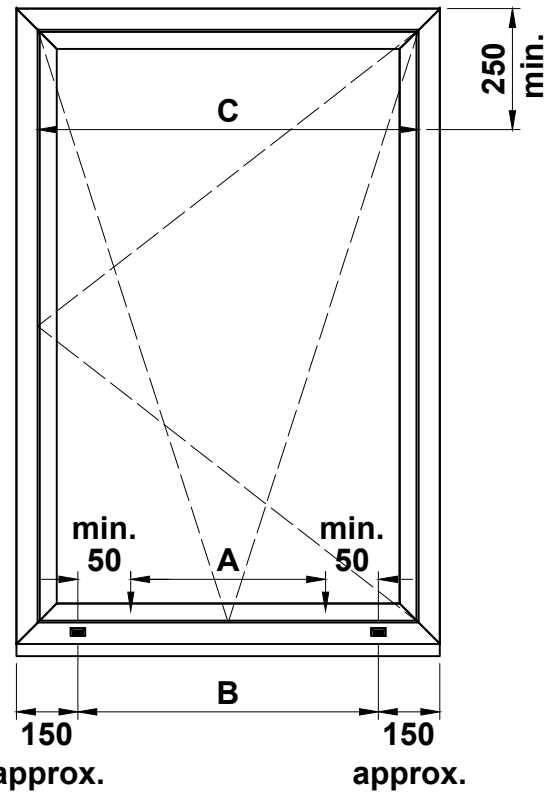

**C.**  
**Pressure  
Equalization**

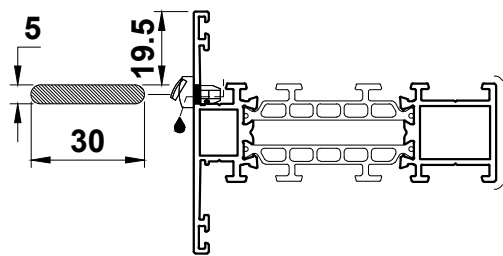
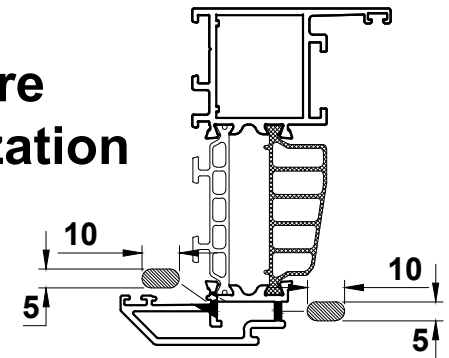

**B1.**  
**Transom Drainage**

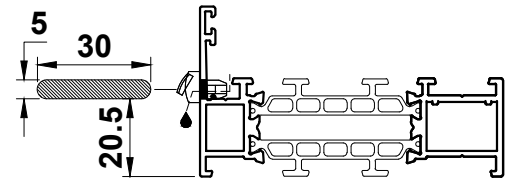

**B2.**  
**Cill Drainage**

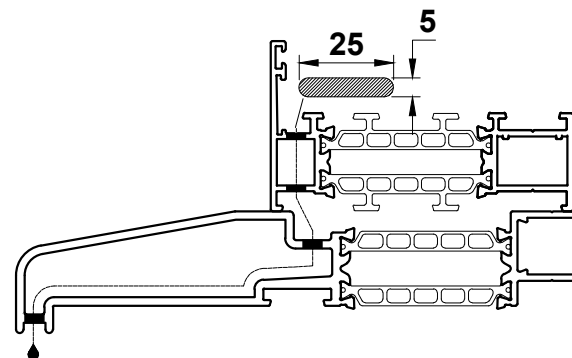

**B3.**  
**Alternative  
Cill Drainage**

Do Not Scale From This Drawing

Outer Frame Gasket & Sash Corner Prep

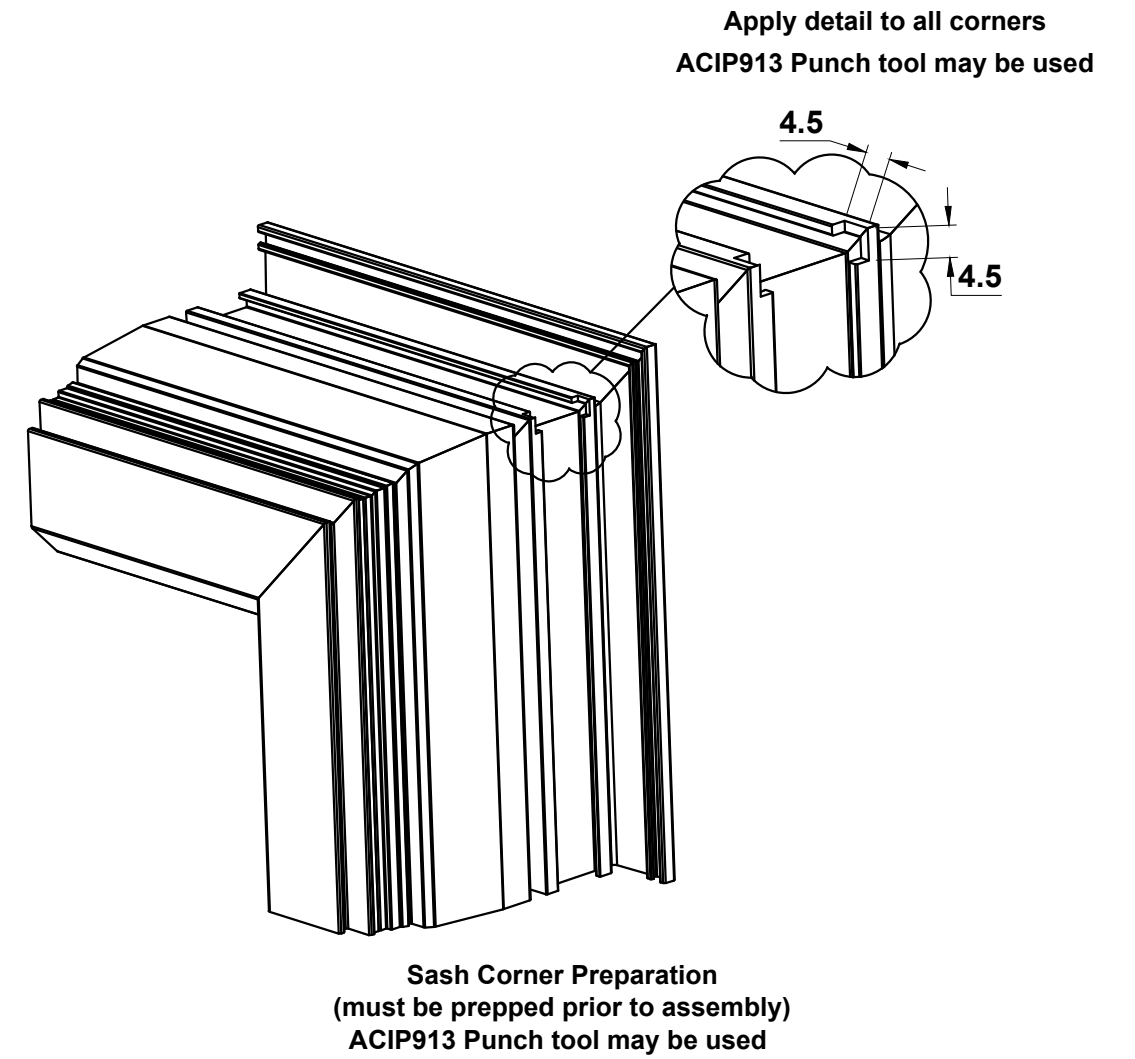
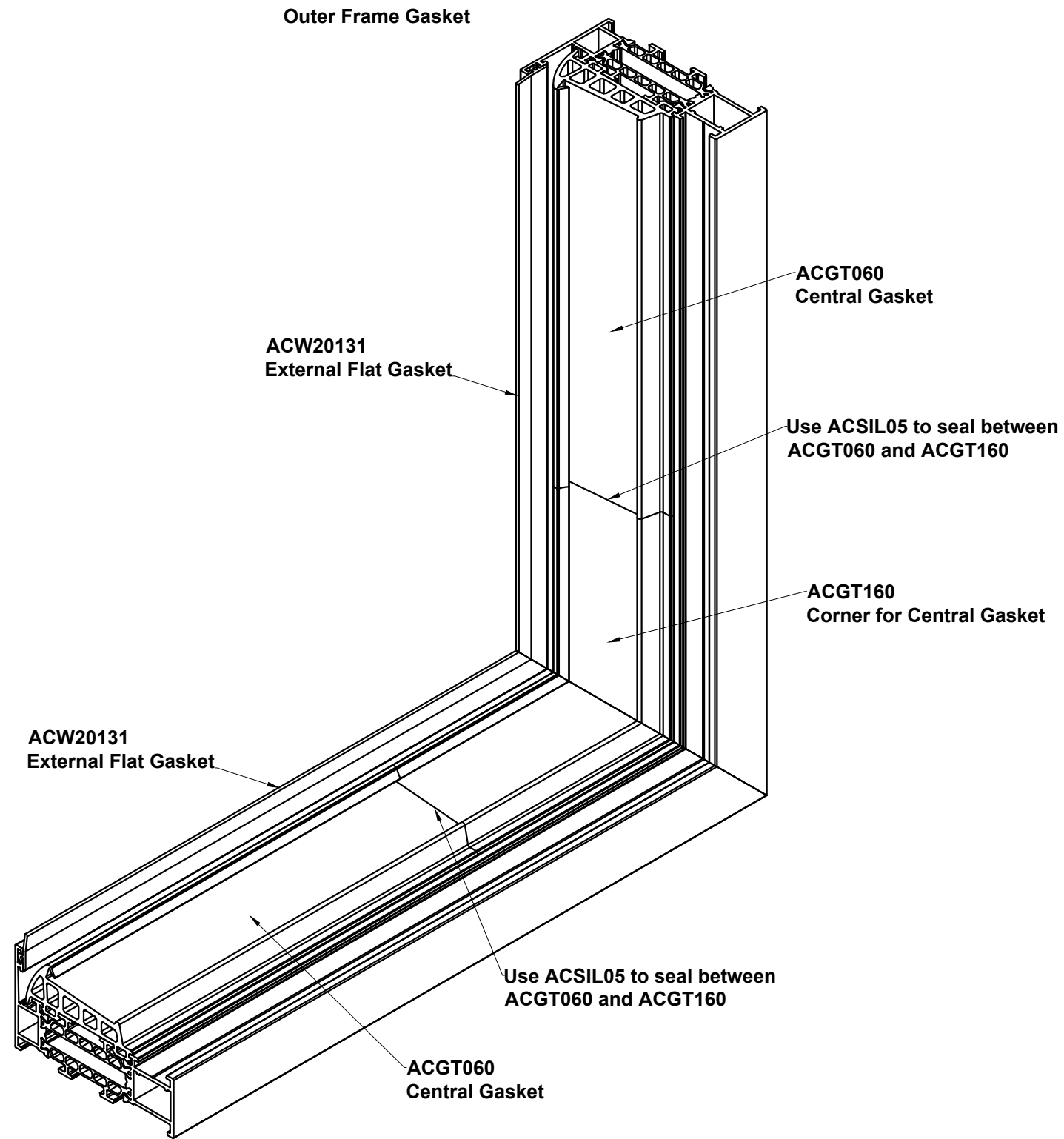

Do Not Scale From This Drawing

Standard Handle Machining

FORK DRIVE

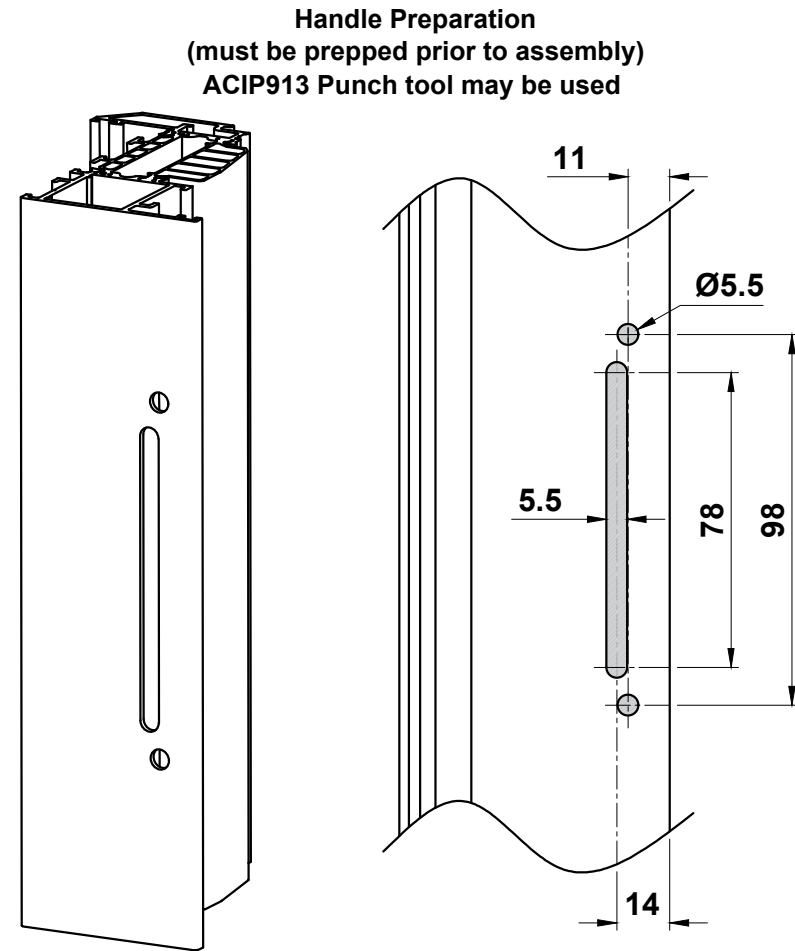

SPINDLE DRIVE

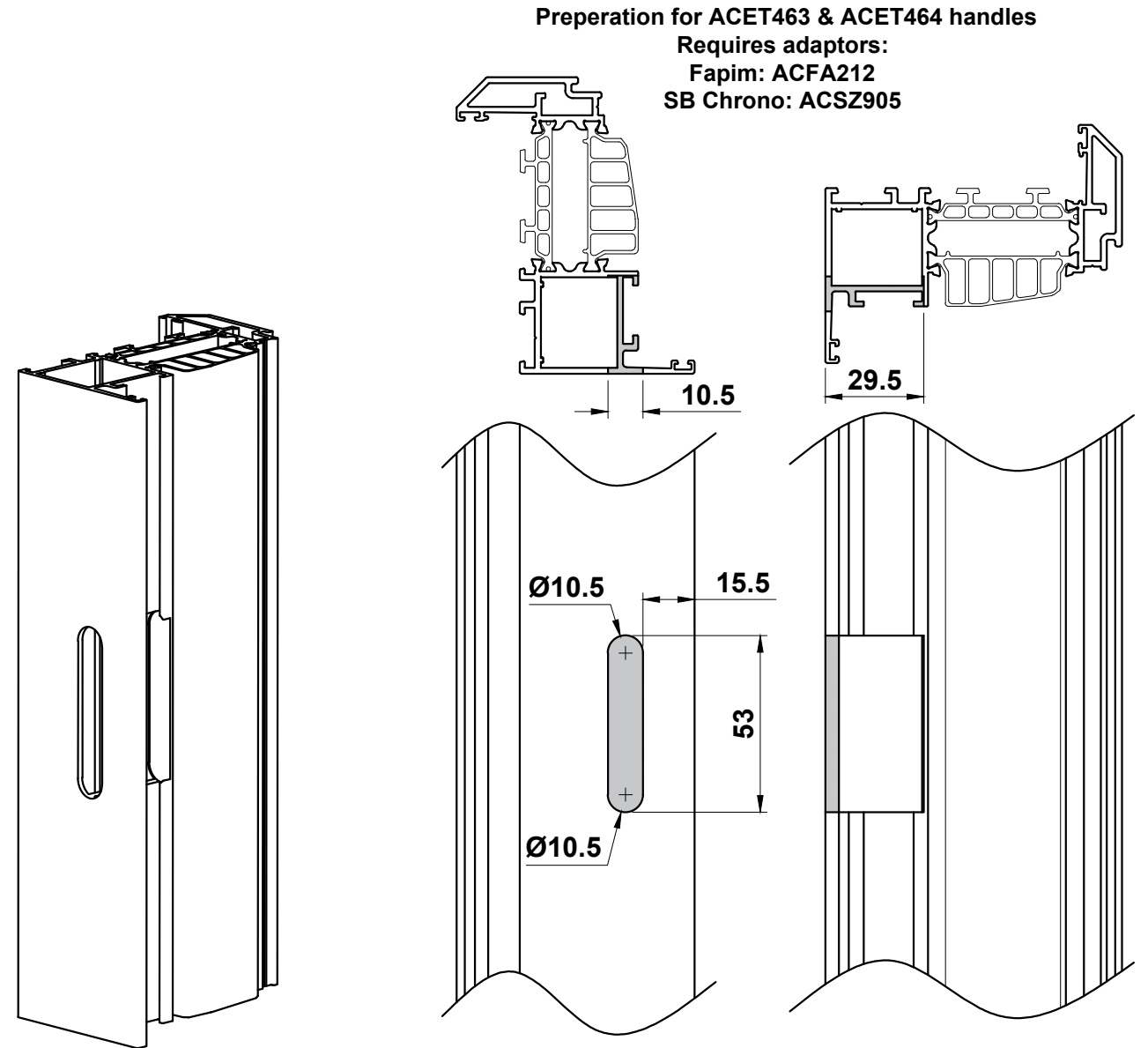

Do Not Scale From This Drawing

Tilt & Turn Overview

Fapim Tilt & Turn Hardware

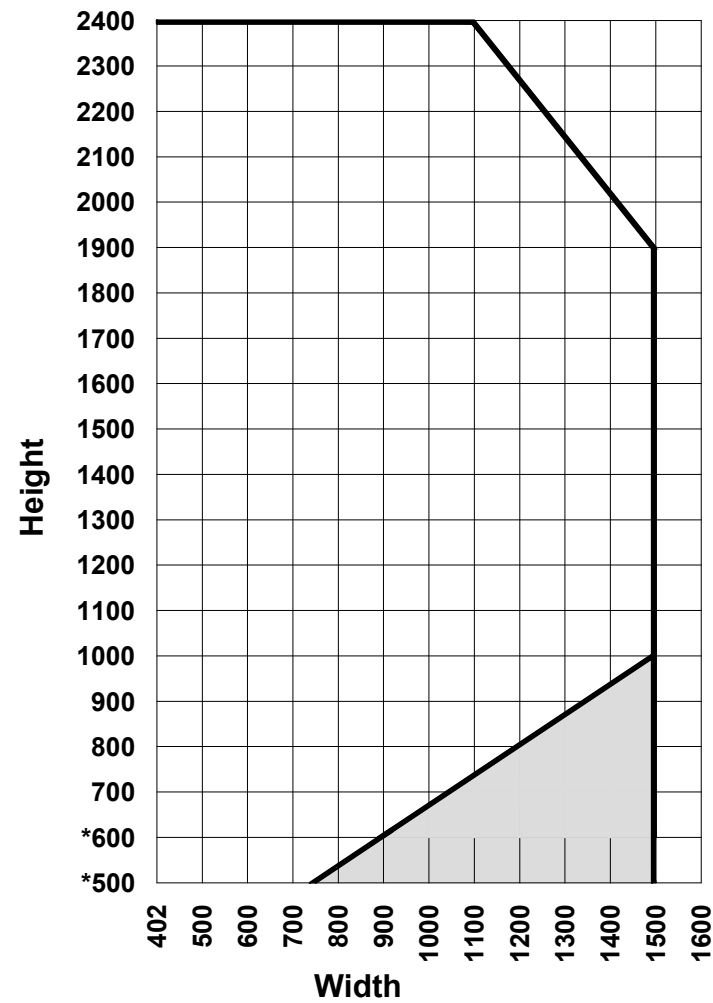

Sobinco Tilt & Turn Hardware

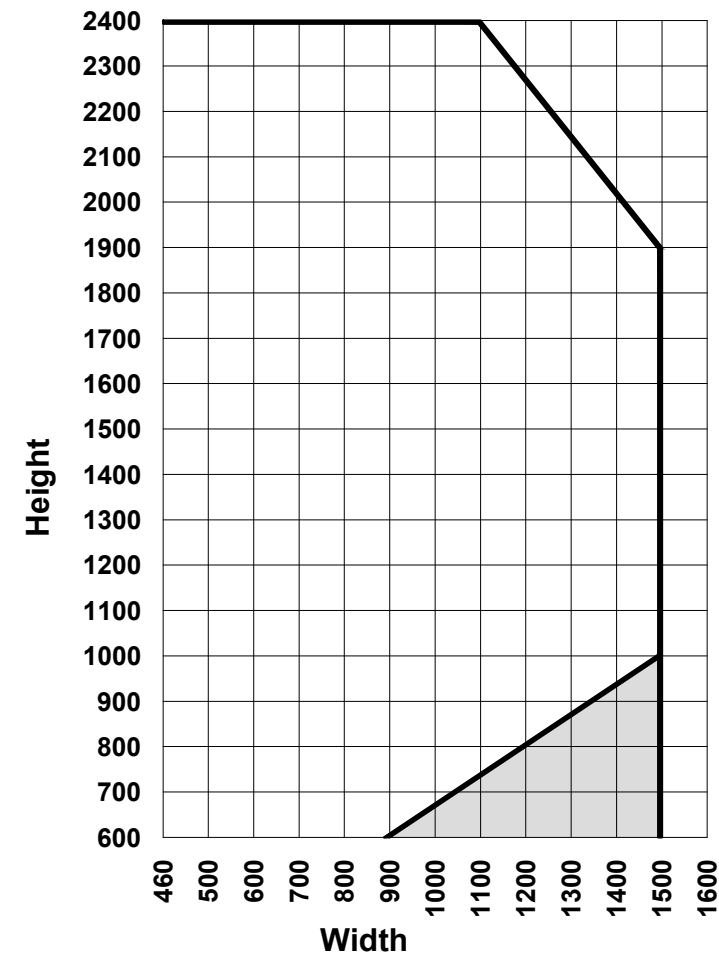

Important Note:  
For PAS24 use Sobinco Safe Invision

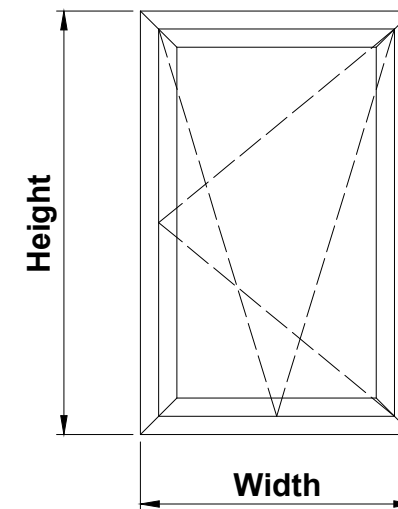

Important Notes:

1. The size limitations of the chosen tilt & turn hardware must be adhered to
2. The width of the sash cannot be more than 1.5 times the height
3. Maximum sash weight = 90kg
4. Please refer to the tilt & turn hardware manuals for the latest information.

Please Note:

When using UL115 outer frame, we recommend using the Chrono Invision tilt & turn gear to avoid issue with the internal render. Alternatively, extension section UL056 maybe used.  
Please see the SB Chrono manual or the Fapim manual for full gearing details

**ACUN3140 Hinge**

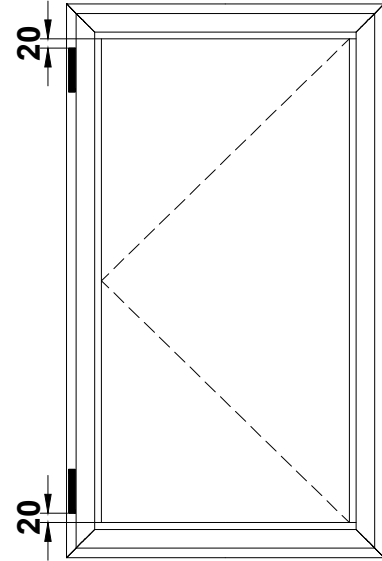

2 Hinge Locations

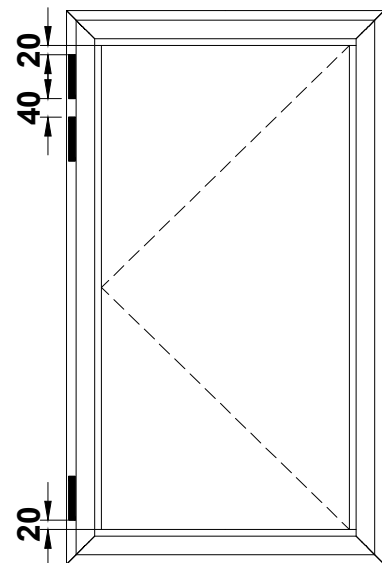

3 Hinge Locations

**ACUN3140 - Hinge Limitations**

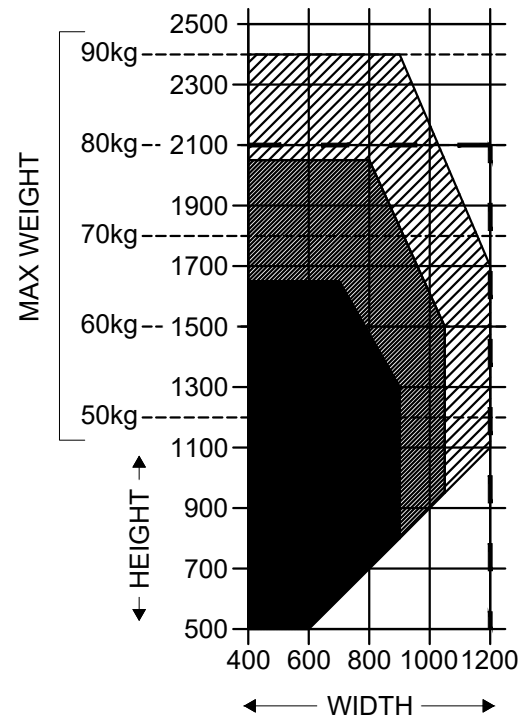

FOR BOTTOM OR SIDE HUNG OPEN IN WINDOWS. (hardware by others)

**Please note:**  
Sash and Hinge Limitations are different.

Anything fabricated outside of Smart Systems Ltd. sash limitations will not be covered by Kitemark.

Smart Systems Ltd. sash size limitations

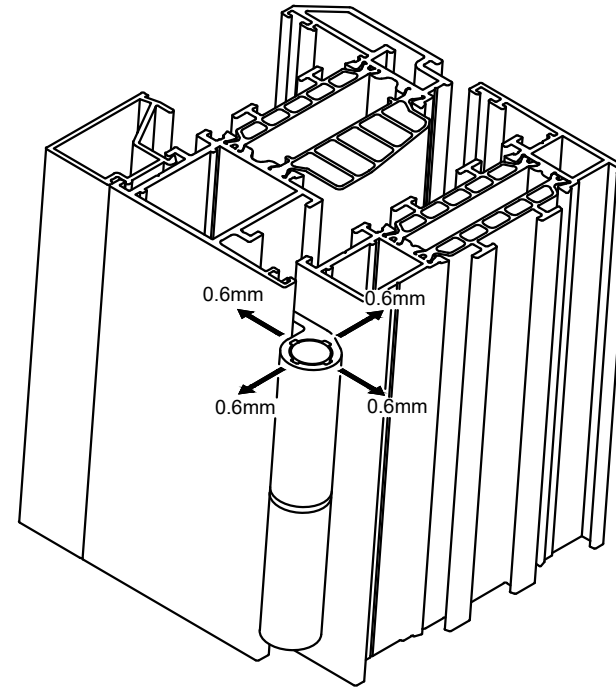

**ACUN3140 - Hinge Assembly**

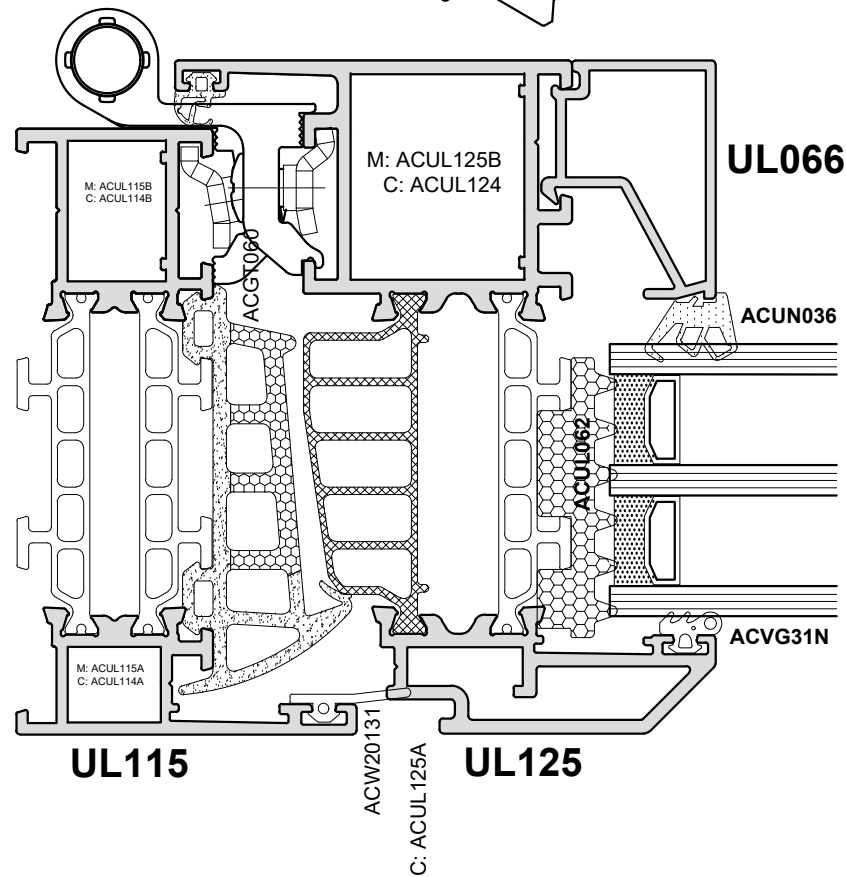
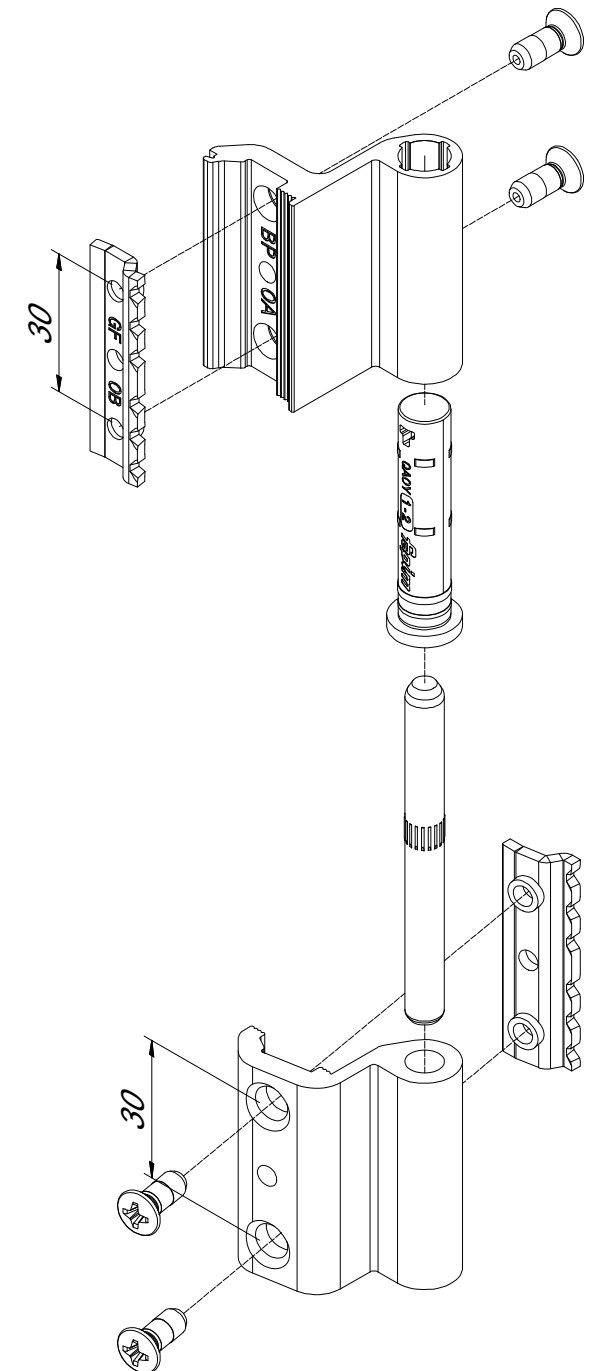

**Do Not Scale From This Drawing**

Mullion/Transom Detail

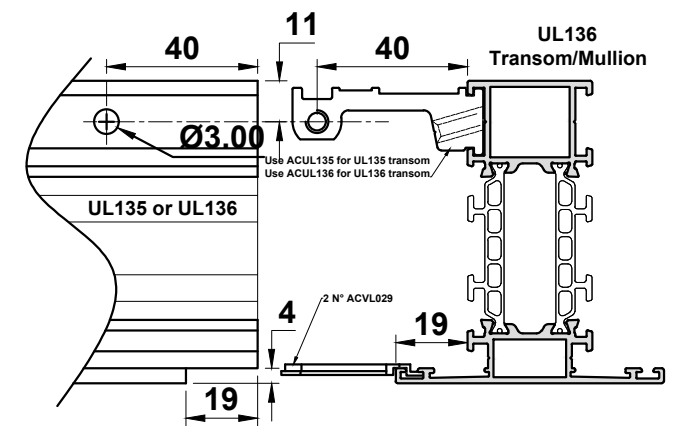
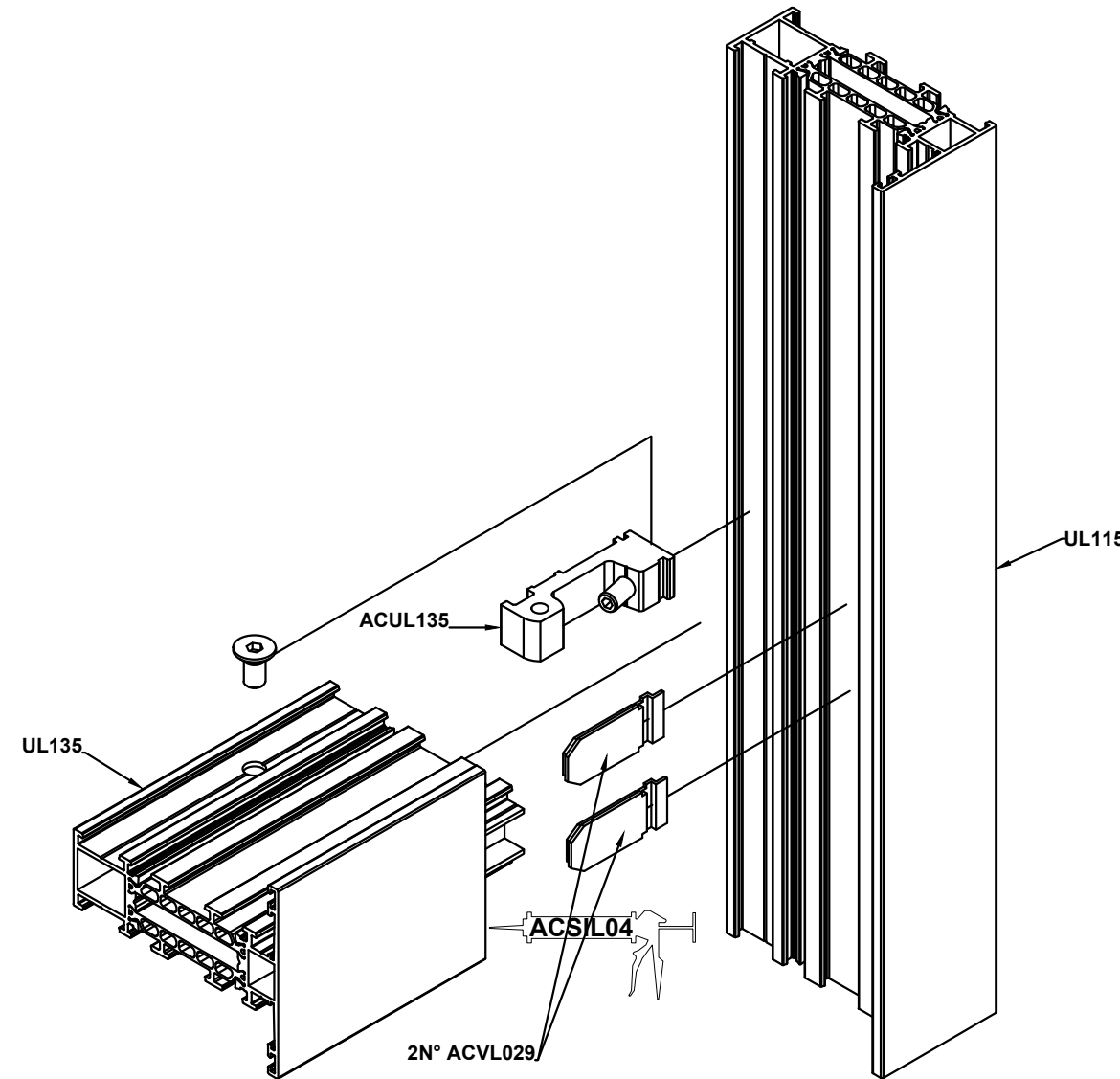
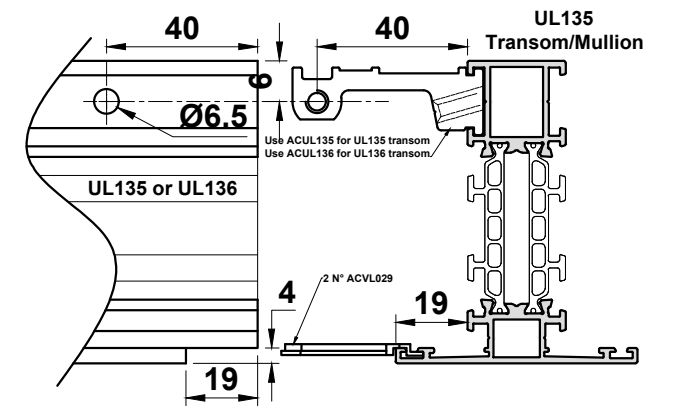
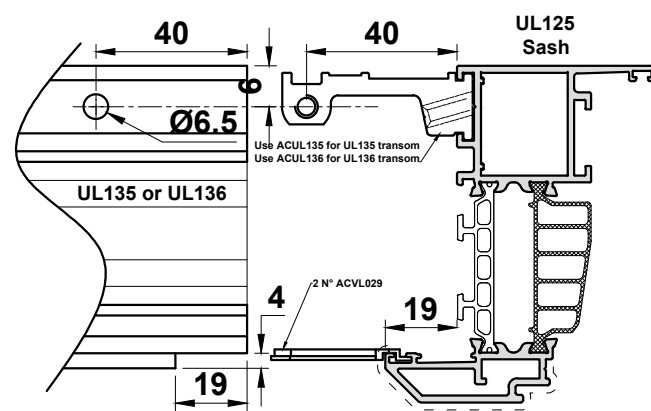
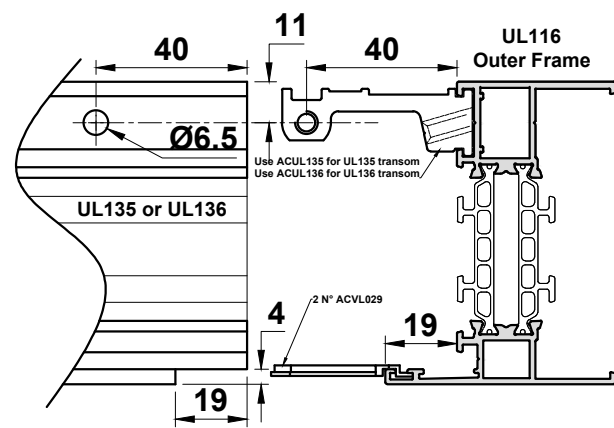
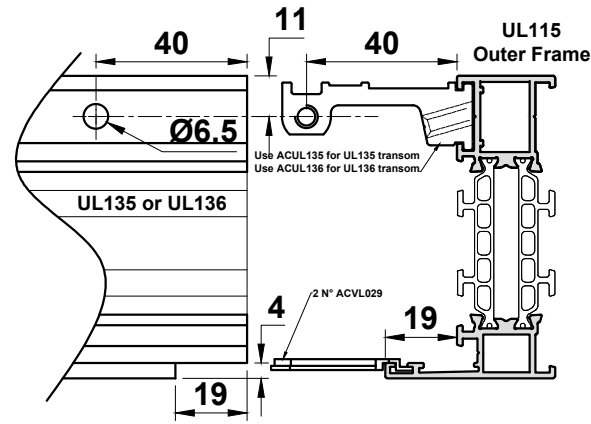

**Note:**  
End mill cutters can be ordered through Smart Systems Ltd.  
Please contact the Technical Department for an order form.  
Standard delivery is 2-3 weeks approx.

Do Not Scale From This Drawing

Glazing Chart

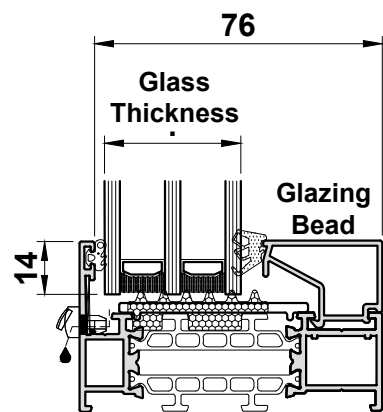
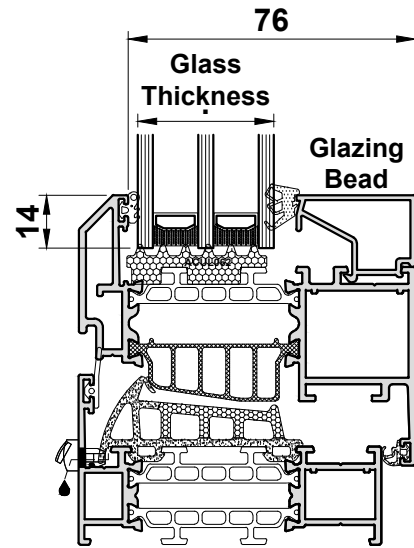

Glass Thickness	External Gasket	Internal Gasket	Glazing Bead
22	ACVG31N	ACUN036	UL063
23	ACVG31N	ACUN036	UL063
24	ACVG31N	ACUN033	UL063
25	ACVG31N	ACUN033	UL063
26	ACVG31N	ACUN036	UL064
27	ACVG31N	ACUN036	UL064
28	ACVG31N	ACUN033	UL064
29	ACVG31N	ACUN033	UL064
30	ACVG31N	ACUN036	UL065
31	ACVG31N	ACUN036	UL065
32	ACVG31N	ACUN033	UL065
33	ACVG31N	ACUN033	UL065
36	ACVG31N	ACUN036	UL066
37	ACVG31N	ACUN033	UL066
38	ACVG31N	ACUN033	UL066
39	ACVG31N	ACUN033	UL066
40	ACVG31N	ACUN036	UL067
41	ACVG31N	ACUN036	UL067
42	ACVG31N	ACUN033	UL067
43	ACVG31N	ACUN033	UL067
45	ACVG31N	ACUN036	UL068
46	ACVG31N	ACUN036	UL068
47	ACVG31N	ACUN033	UL068
48	ACVG31N	ACUN033	UL068
49	ACVG31N	ACUN036	UL069
50	ACVG31N	ACUN036	UL069
51	ACVG31N	ACUN033	UL069
52	ACVG31N	ACUN033	UL069

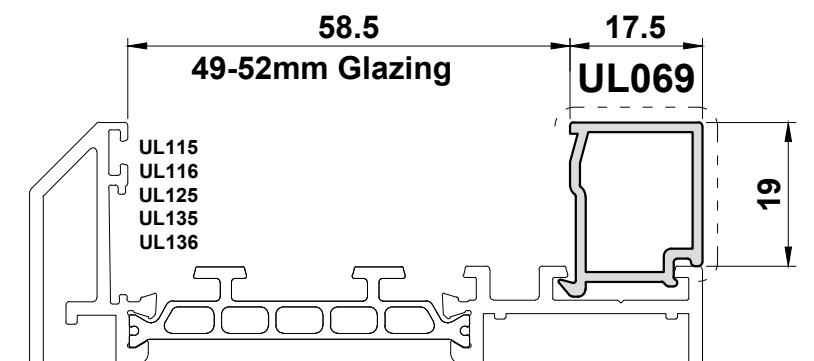
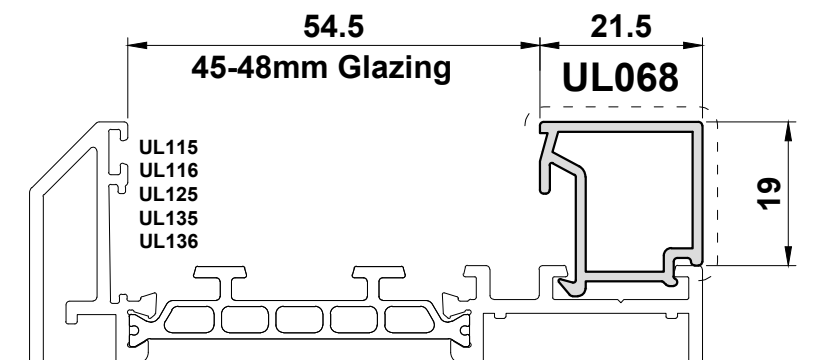
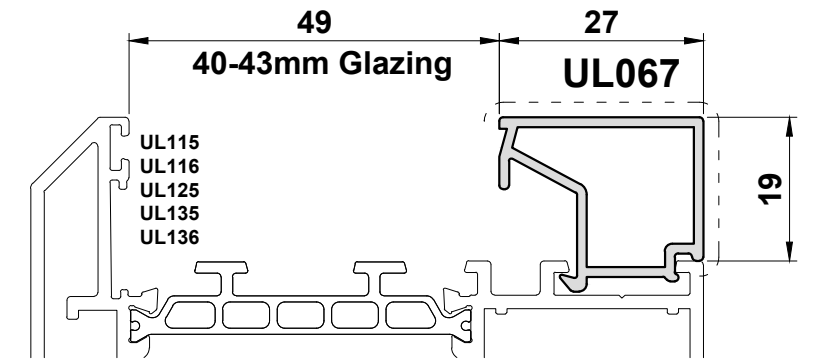
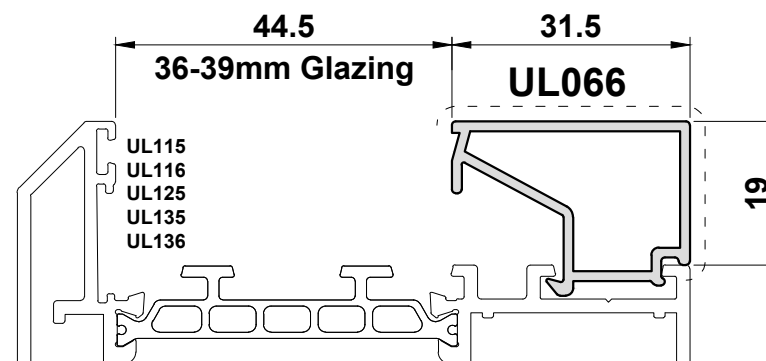
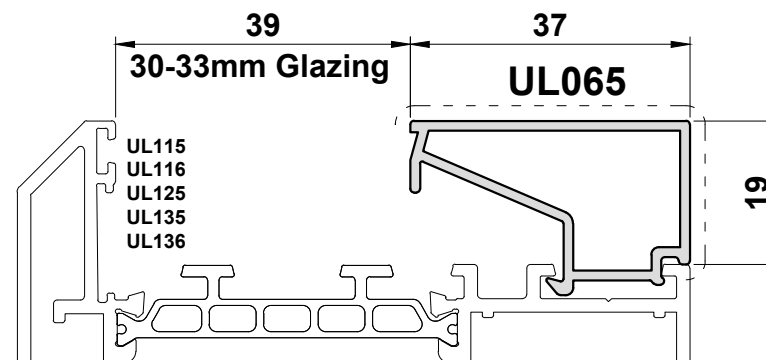
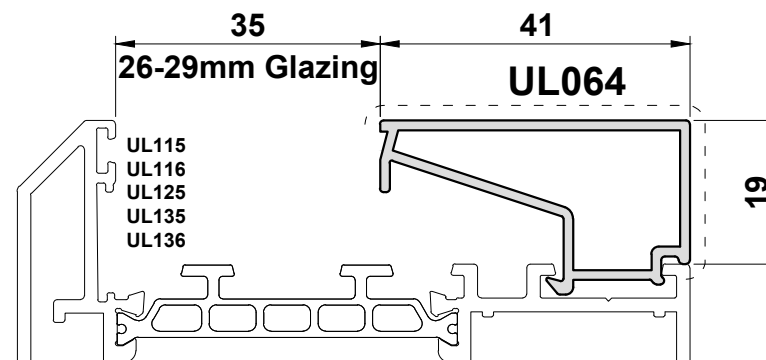
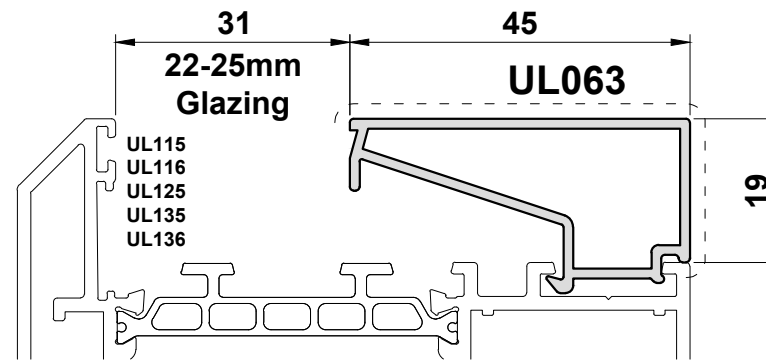

Do Not Scale From This Drawing



**Section F**









Sawing Tables

Cutting information..... F03 - F14

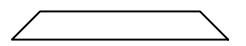
**Section F**

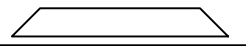
**Cutting Information**

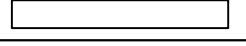
Sections

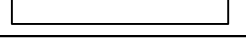
UL115		2		W
UL115		2		H
Bead		2		W-52
Bead		2		H-90

**Glass**  
W - 62 X H - 62

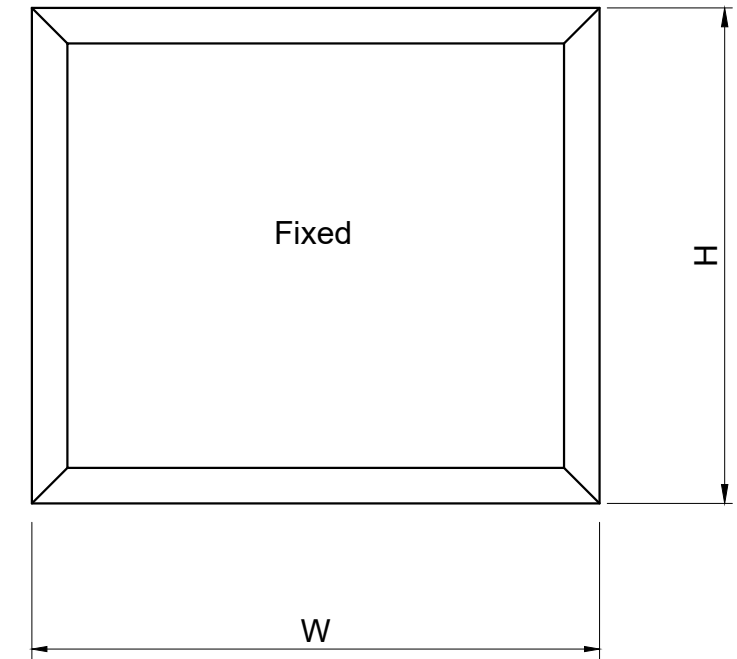

Accessories



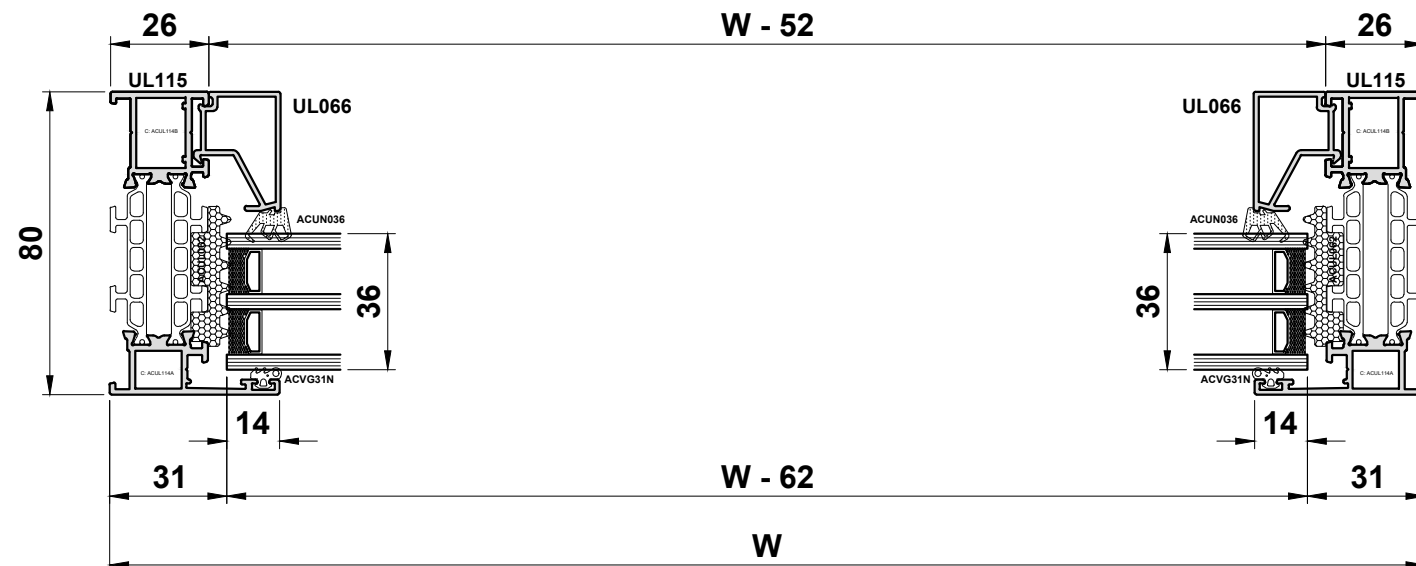
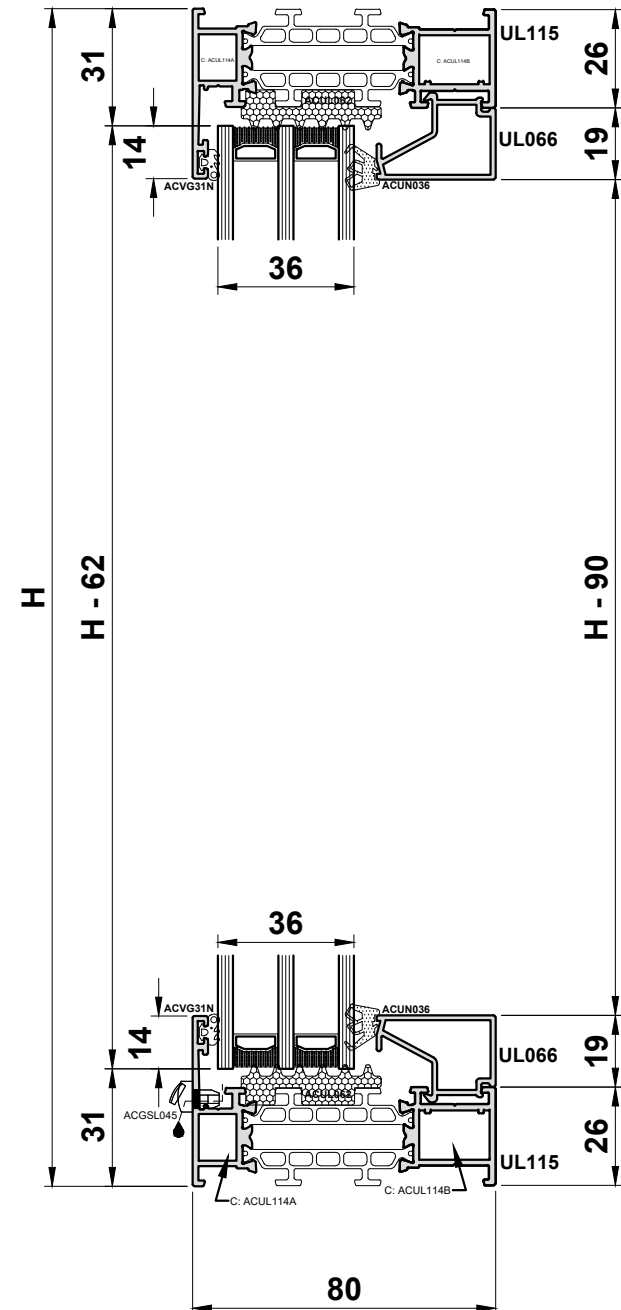





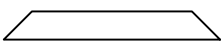

ACUN020	4	Corner Chevron
ACUL114A	4	Outerframe Cleat
ACUL114B	4	Outerframe Cleat
ACVG31N	2 X (W+H)	E Gasket
ACUN036	2 X (W+H)	Wedge Gasket
ACGSL045	2	Drainage Cap

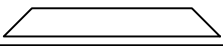

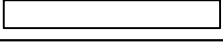
Do Not Scale From This Drawing

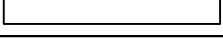
**Cutting Information**

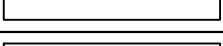
Sections

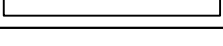
UL115		2		W
UL115		2		H
UL135		1		W-52
Bead		2		W-52
Bead		2		H1-77
Bead		2		H2-77

Glass	
A	W - 62 X H1 - 49
B	W - 62 X H2 - 49

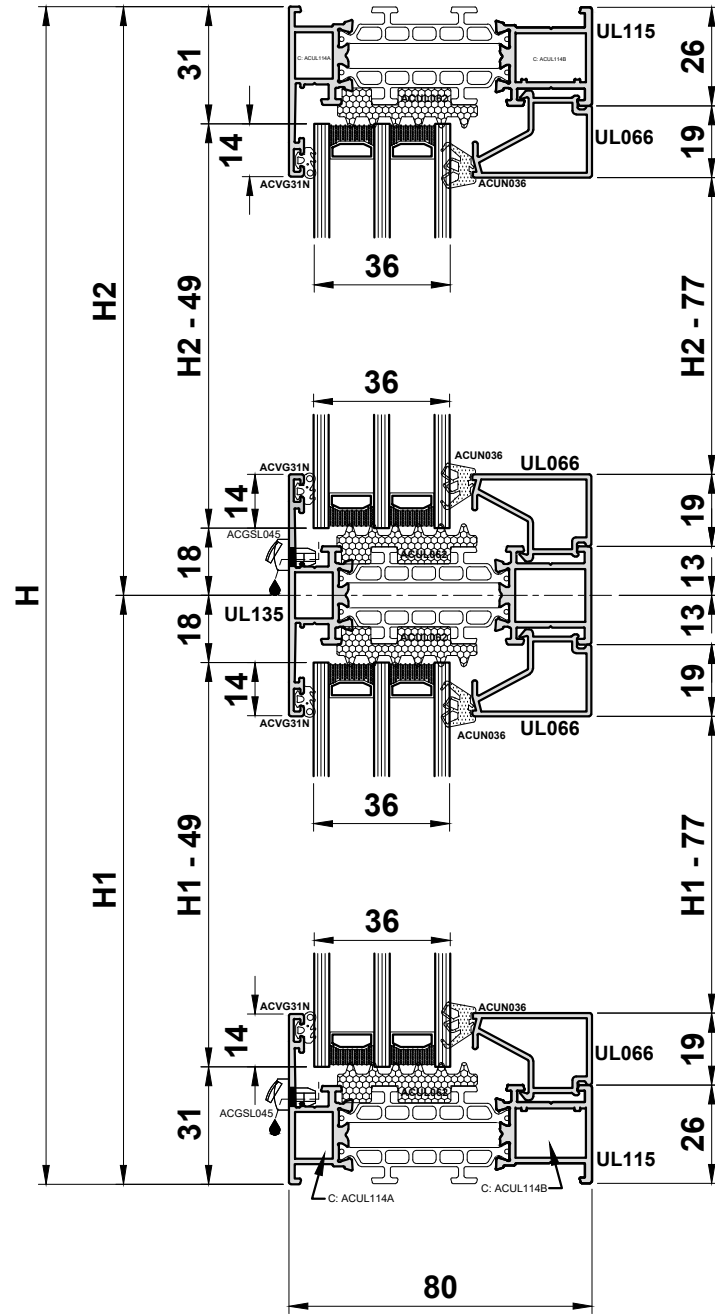
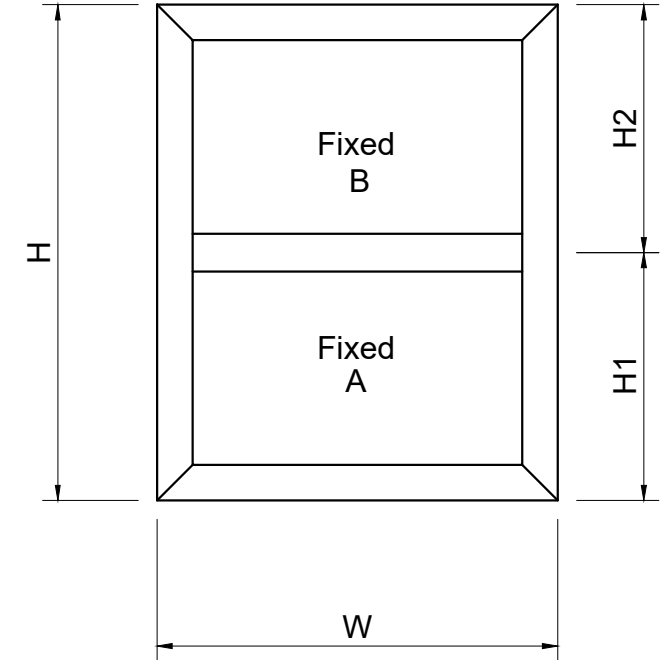

Accessories

ACUN020	4	Corner Chevron
ACUL114A	4	Outerframe Cleat
ACUL114B	4	Outerframe Cleat
ACUL135	2	Transom Cleat
ACVL029	4	Strengthening Piece
ACVG31N	4 X W + 2 X H	E Gasket
ACUN036	4 X W + 2 X H	Wedge Gasket
ACGSL045	4	Drainage Cap

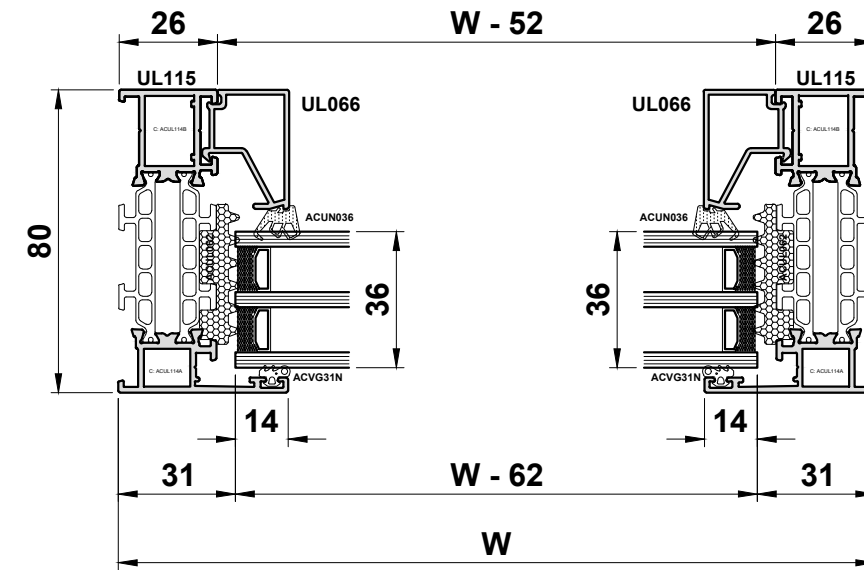

Do Not Scale From This Drawing

**Cutting Information**

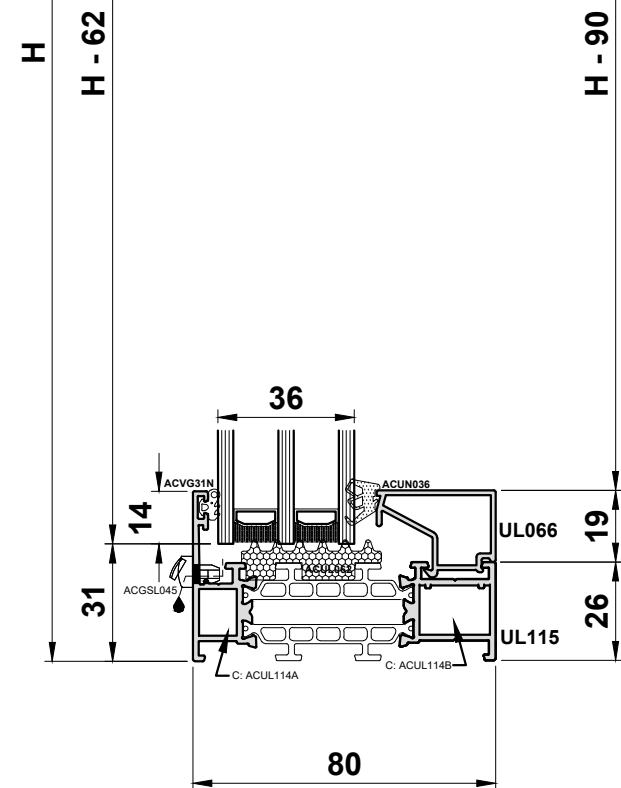
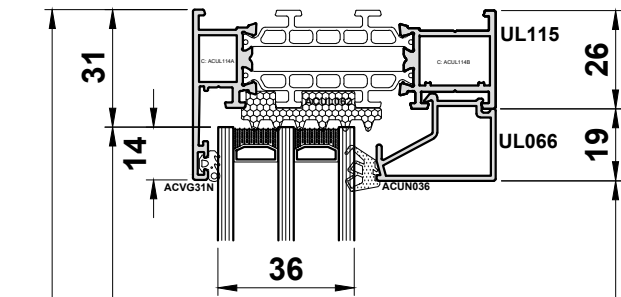

Sections

UL115		2		W
UL115		2		H
UL136		1		H-52
Bead		2		W1-42.5
Bead		2		W2-42.5
Bead		4		H-90

Glass	
A	W1 - 52.5 X H - 62
B	W2 - 52.5 X H - 62

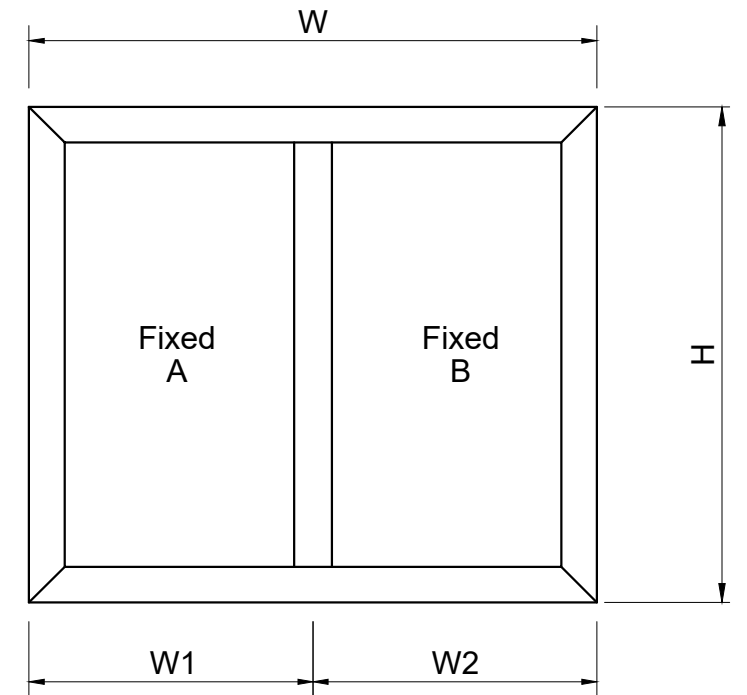

Accessories



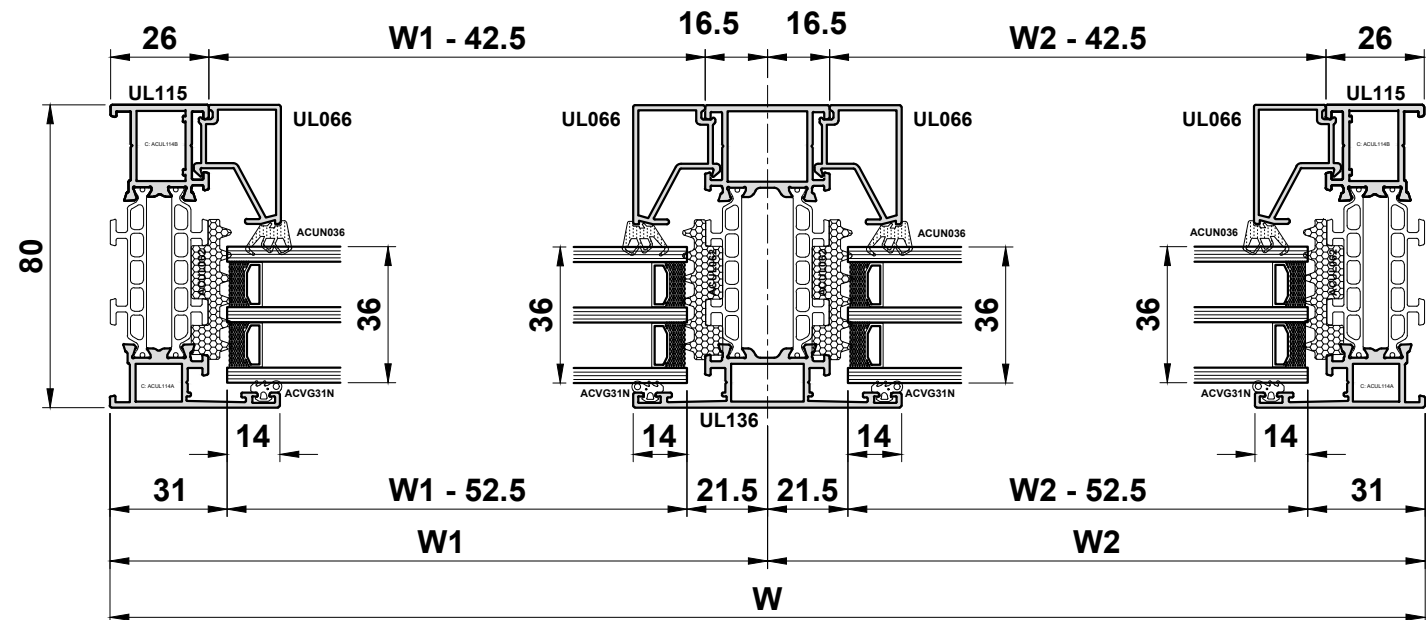





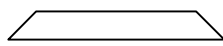

ACUN020	4	Corner Chevron
ACUL114A	4	Outerframe Cleat
ACUL114B	4	Outerframe Cleat
ACUL136	2	Mullion Cleat
ACVL029	4	Strengthening Piece
ACVG31N	2 X W + 4 X H	E Gasket
ACUN036	2 X W + 4 X H	Wedge Gasket
ACGSL045	4	Drainage Cap

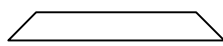

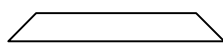
Do Not Scale From This Drawing

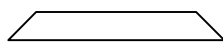
Cutting Information

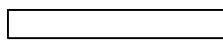
Sections

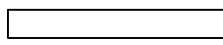
UL115		2		W
UL115		2		H
UL125		2		W-42
UL125		2		H-42
Bead		2		W-147
Bead		2		H-185

Accessories

ACUN020	8	Corner Chevron
ACUL114A	4	Outerframe Cleat
ACUL114B	4	Outerframe Cleat
ACUL124	4	Sash Cleat
ACUL125A	4	Sash Cleat
ACW20131	2 X (W+H)	External Flat Gasket
ACGT060	2 X (W+H)	Central Gasket
ACGT160	4	Central Gasket Corner
ACGT062	2 X (W+H)	5mm Flipper Gasket
ACUL062	2 X (W+H)	Glazing Foam
ACVG31N	2 X (W+H)	E Gasket
ACUN036	2 X (W+H)	Wedge Gasket
ACGSL045	2	Drainage Cap

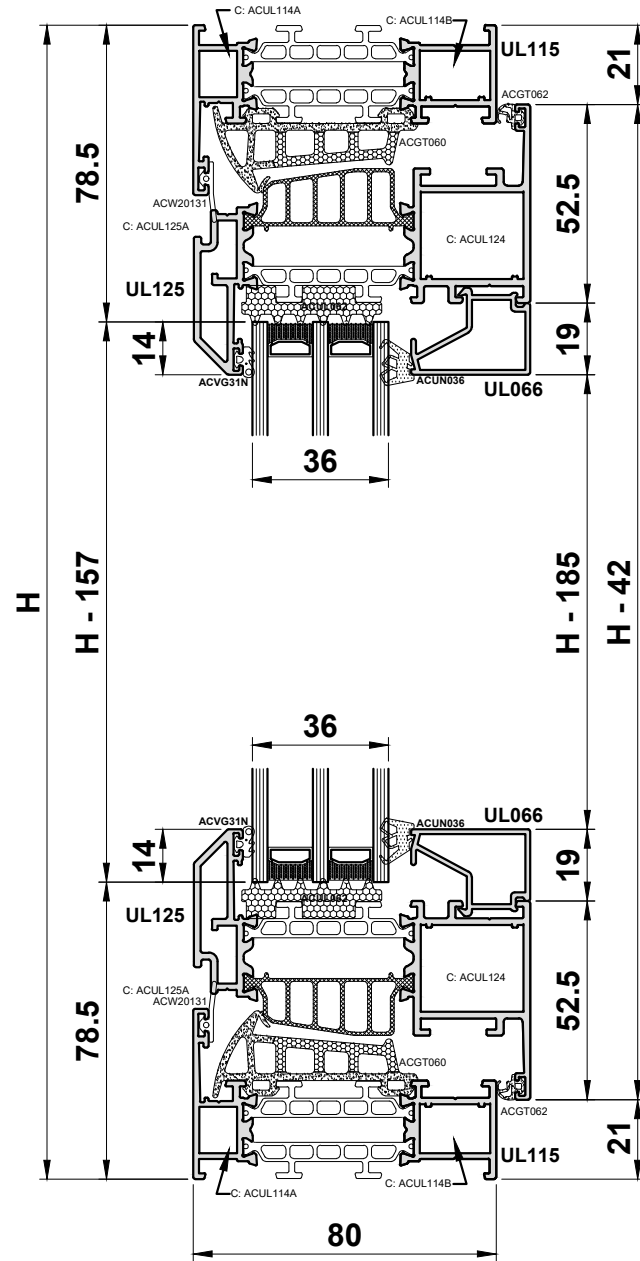
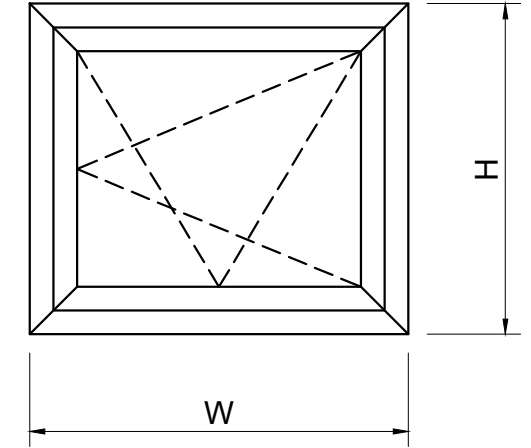

**Glass**  
W - 157 X H - 157

Please refer to the SB Chrono or Fapin manual for tilt & turn hardware.

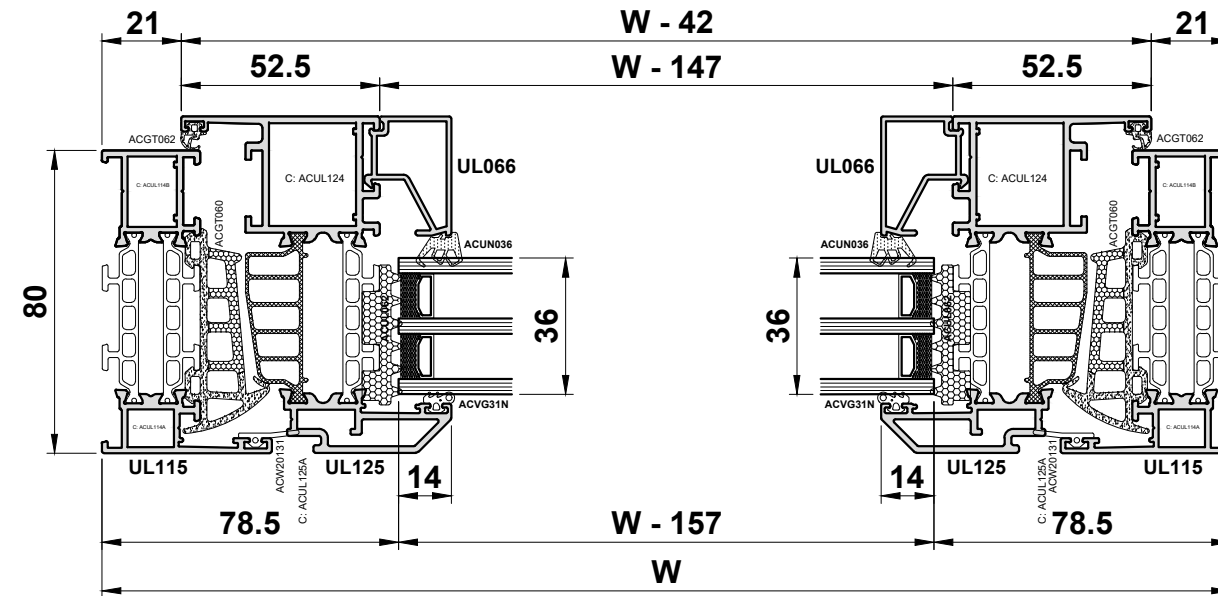

Do Not Scale From This Drawing

Cutting Information

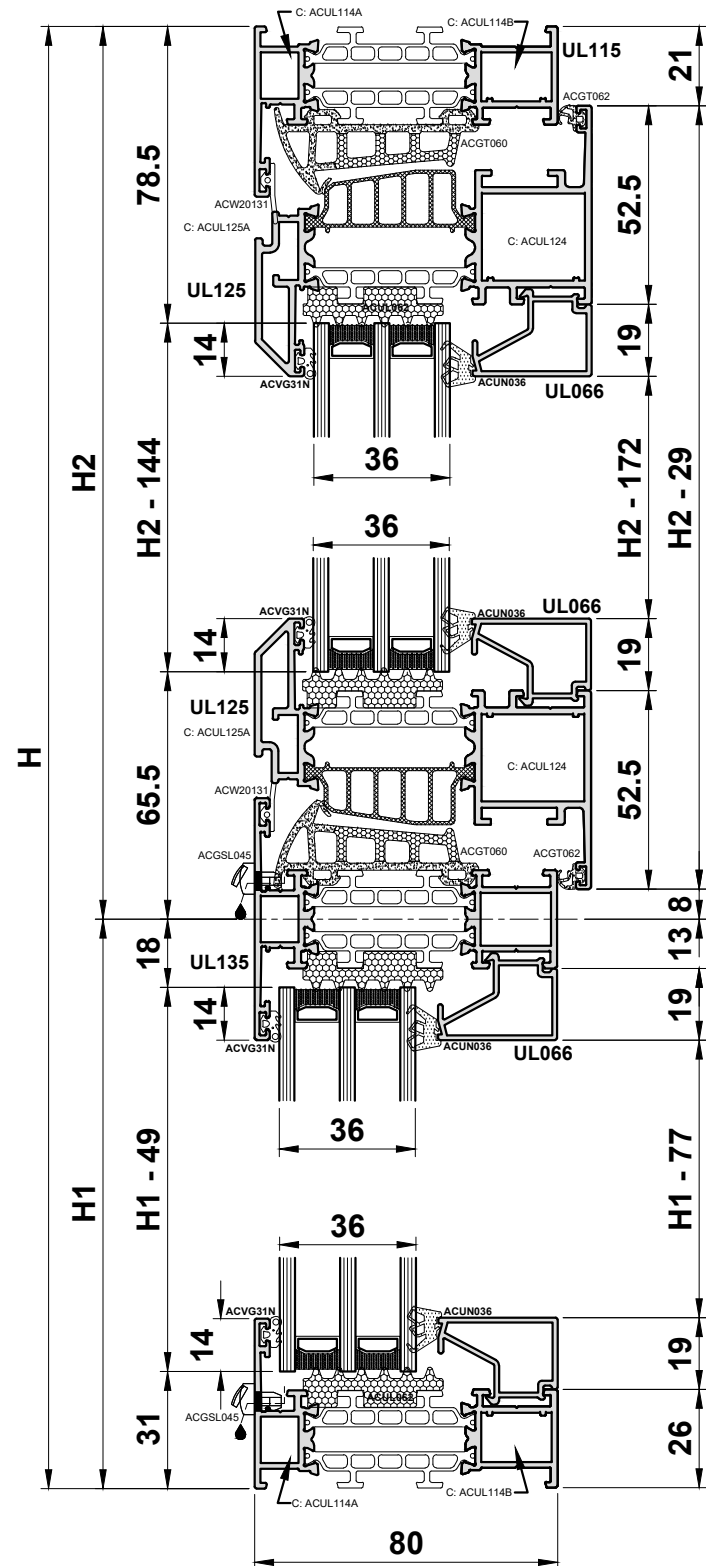

Sections

UL115		2		W
UL115		2		H
UL125		2		W-42
UL125		2		H2-29
UL135		1		W-52
Bead		2		W-147
Bead		2		W-52
Bead		2		H1-77
Bead		2		H2-172

Glass

A	W - 62 X H1 - 49
B	W - 157 X H2 - 144

Accessories

ACUN020	8	Corner Chevron
ACUL114A	4	Outerframe Cleat
ACUL114B	4	Outerframe Cleat
ACUL124	4	Sash Cleat
ACUL125A	4	Sash Cleat
ACUL135	2	Transom Cleat
ACVL029	4	Strengthening Piece
ACW20131	2 X (W+H2)	External Flat Gasket
ACGT060	2 X (W+H2)	Central Gasket
ACGT160	4	Central Gasket Corner
ACGT062	2 X (W+H2)	5mm Flipper Gasket
ACUL062	4 X W + 2 X H	Glazing Foam
ACVG31N	4 X W + 2 X H	E Gasket
ACUN036	4 X W + 2 X H	Wedge Gasket
ACGSL045	4	Drainage Cap

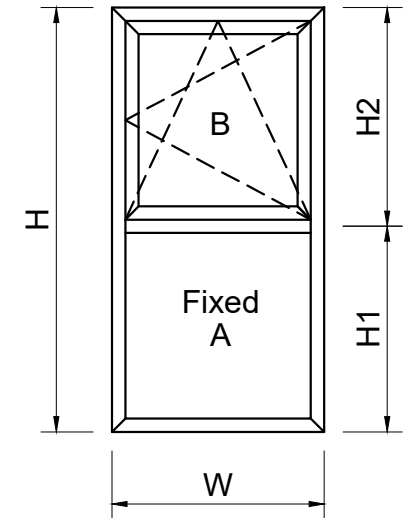

Please refer to the SB Chrono or Fapin manual for tilt & turn hardware.

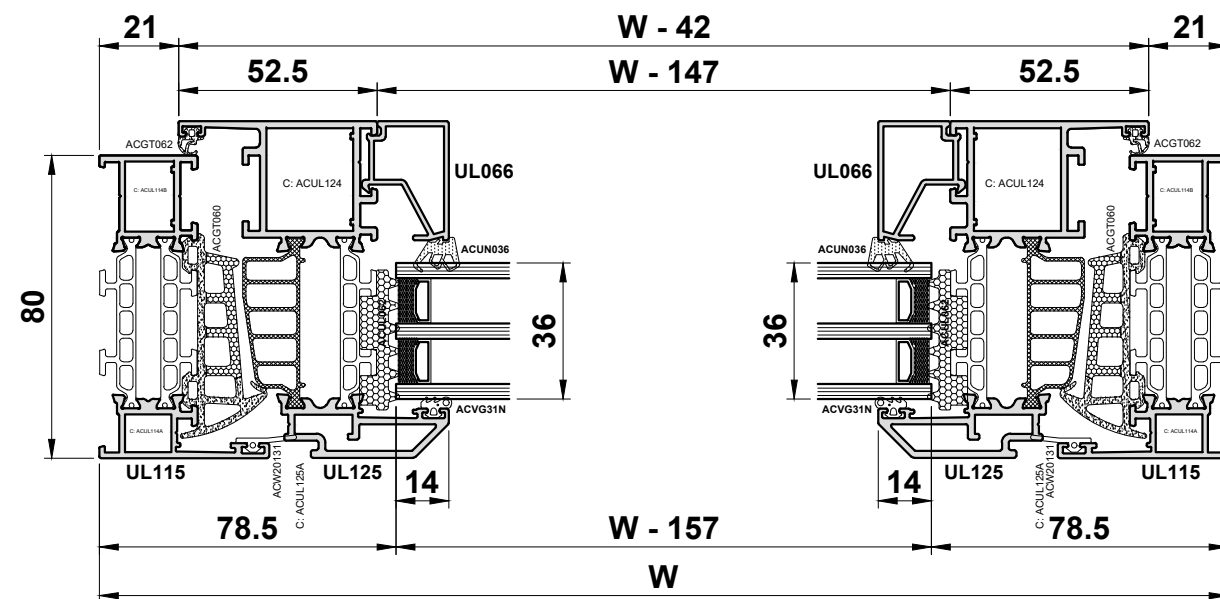

Do Not Scale From This Drawing

**Cutting Information**

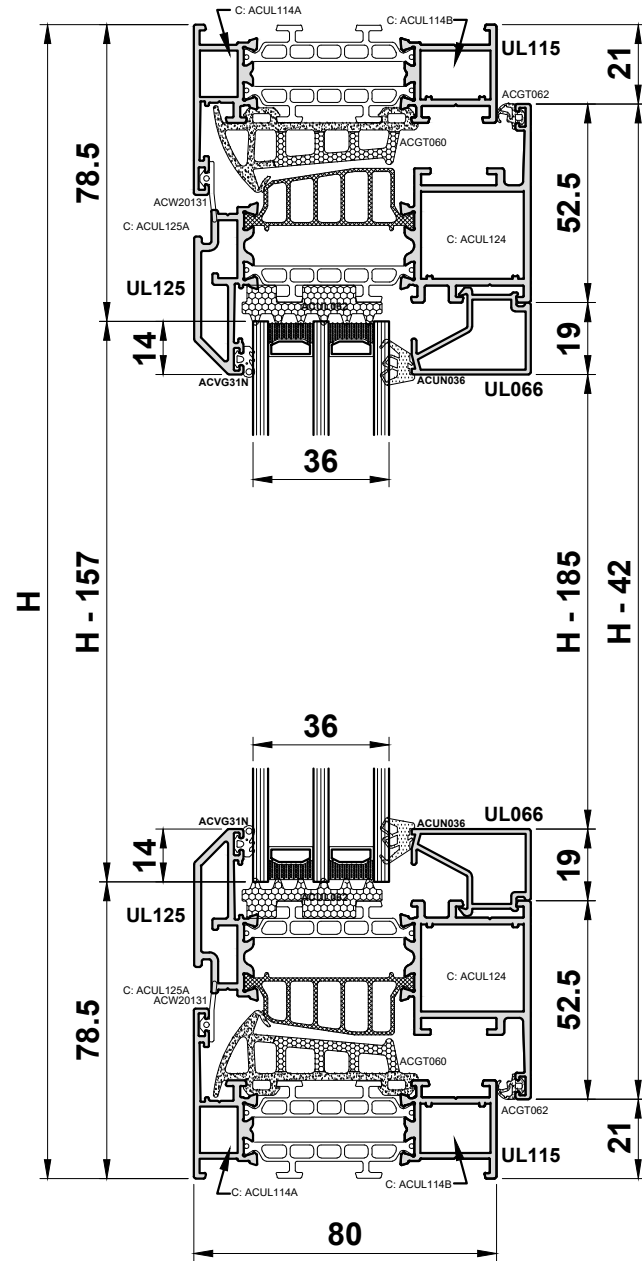

**Sections**

UL115		2		W
UL115		2		H
UL125		2		W1-32.5
UL125		2		W2-32.5
UL125		4		H-42
UL136		1		H-52
Bead		2		W1-137.5
Bead		2		W2-137.5
Bead		4		H-185

**Glass**

A	<b>W1 - 147.5 X H - 157</b>
B	<b>W2 - 147.5 X H - 157</b>

**Accessories**

ACUN020	12	Corner Chevron
ACUL114A	4	Outerframe Cleat
ACUL114B	4	Outerframe Cleat
ACUL124	8	Sash Cleat
ACUL125A	8	Sash Cleat
ACUL136	2	Mullion Cleat
ACVL029	4	Strengthening Piece
ACW20131	2 X W + 4 X H	External Flat Gasket
ACGT060	2 X W + 4 X H	Central Gasket
ACGT160	8	Central Gasket Corner
ACGT062	2 X W + 4 X H	5mm Flipper Gasket
ACUL062	2 X W + 4 X H	Glazing Foam
ACVG31N	2 X W + 4 X H	E Gasket
ACUN036	2 X W + 4 X H	Wedge Gasket
ACGSL045	4	Drainage Cap

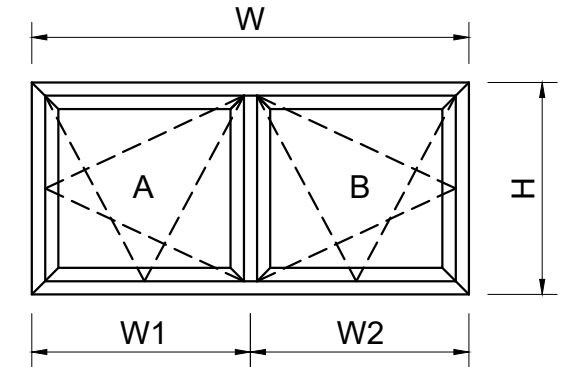

Please refer to the SB Chrono or Fapin manual for tilt & turn hardware.

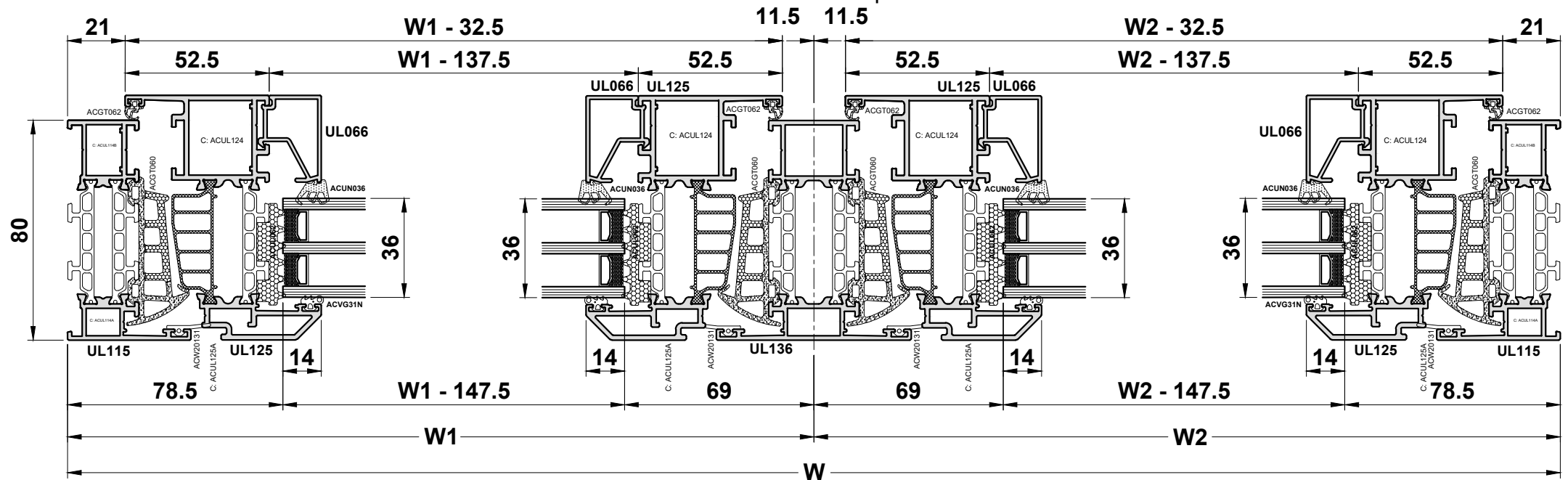







**Do Not Scale From This Drawing**

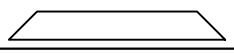

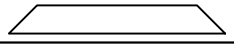
**Cutting Information**

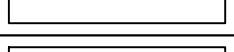
Sections

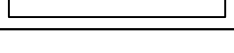
UL116		2		W
UL116		2		H
Bead		2		W-84
Bead		2		H-122

**Glass**  
**W - 94 X H - 94**

Accessories

ACUN020	4	Corner Chevron
ACUL114A	4	Outerframe Cleat
ACUL114B	4	Outerframe Cleat
ACVG31N	2 X (W+H)	E Gasket
ACUN036	2 X (W+H)	Wedge Gasket
ACGSL045	2	Drainage Cap
ACUL116	2 X (W+H)	Perimeter Foam

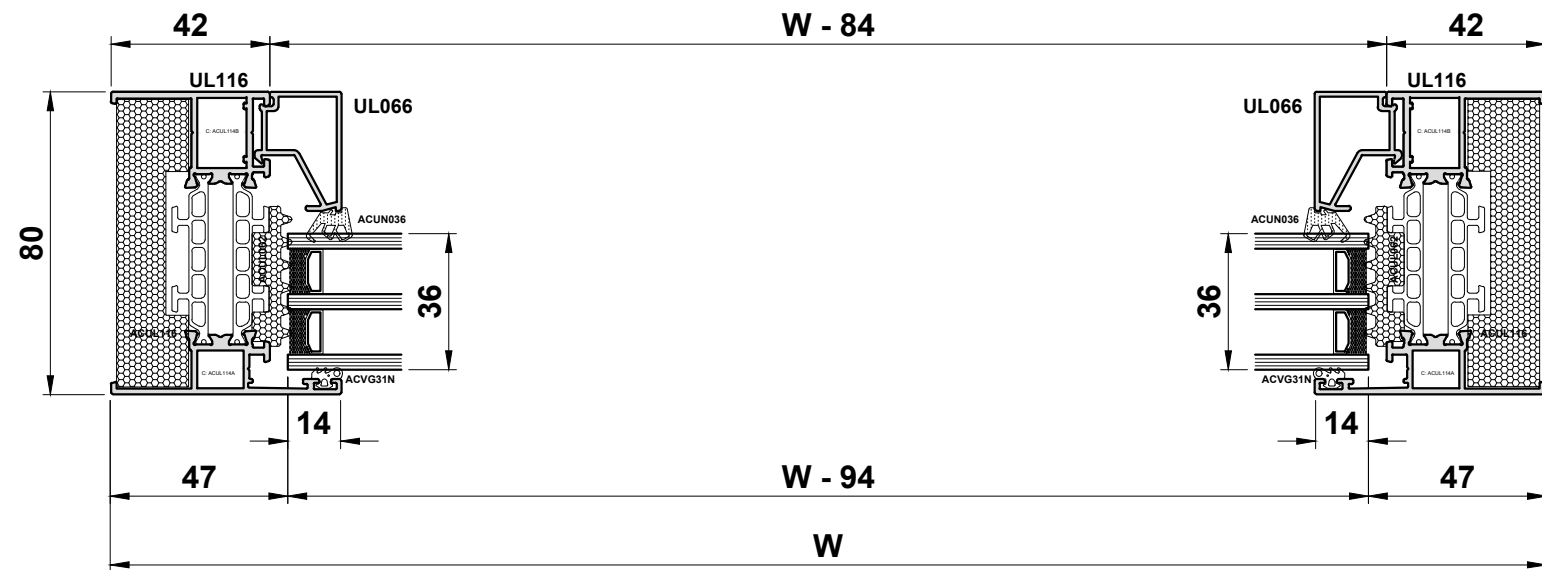
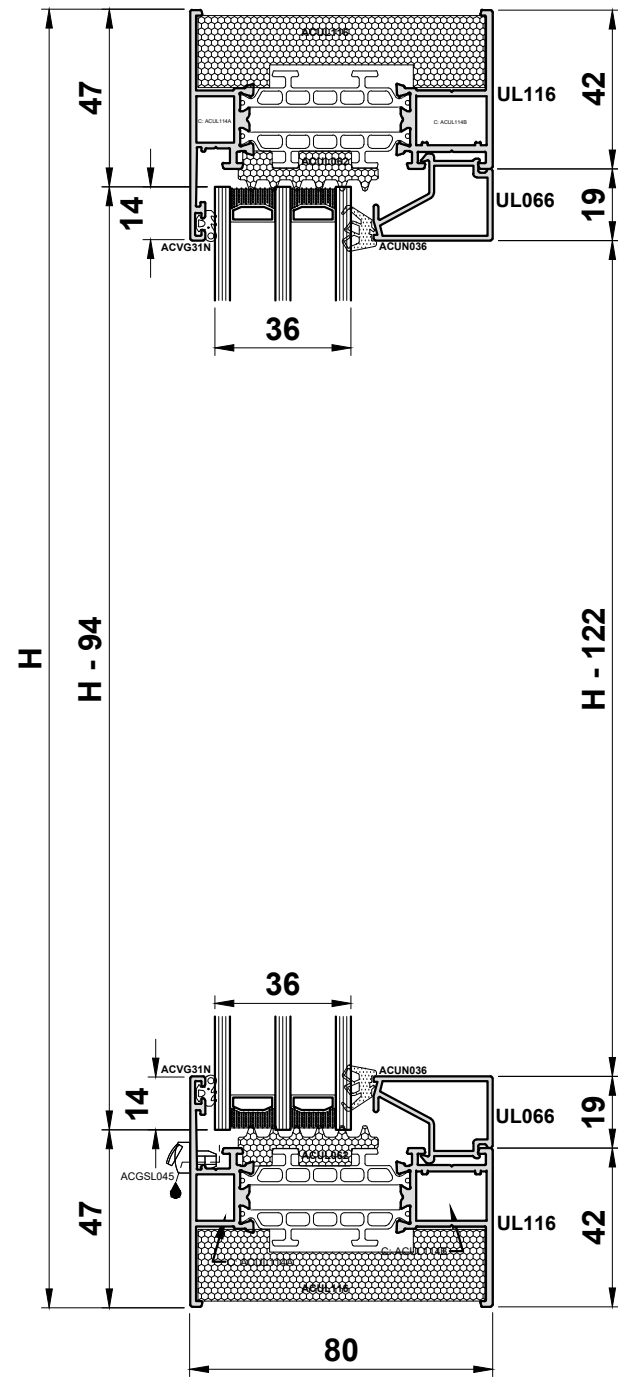
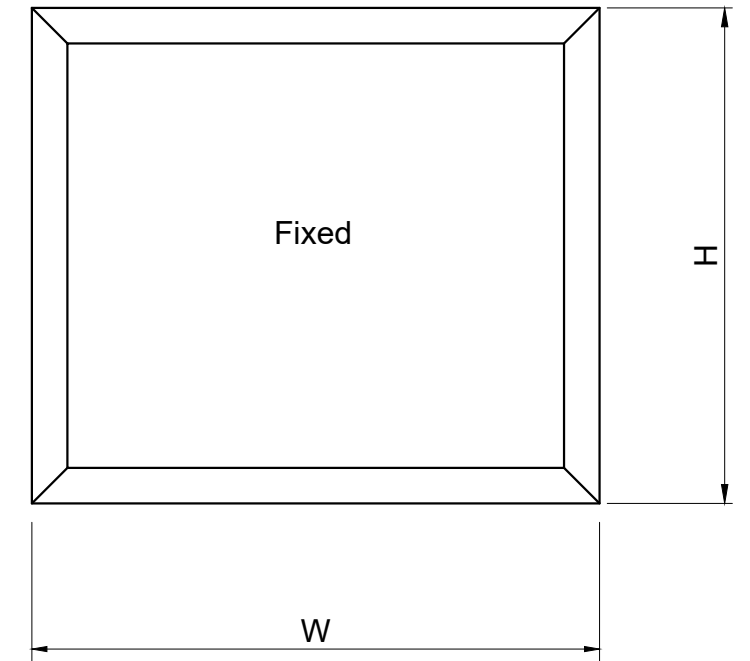

**Do Not Scale From This Drawing**

**Cutting Information**

Sections

UL116		2		W
UL116		2		H
UL135		1		W-84
Bead		2		W-84
Bead		2		H1-93
Bead		2		H2-93

Glass	
A	W - 94 X H1 - 65
B	W - 94 X H2 - 65

Accessories



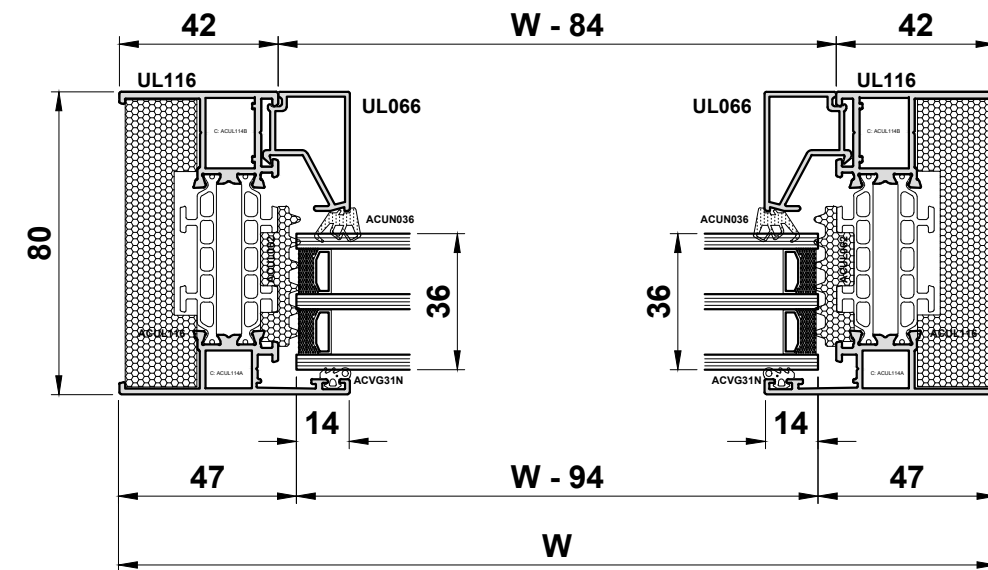
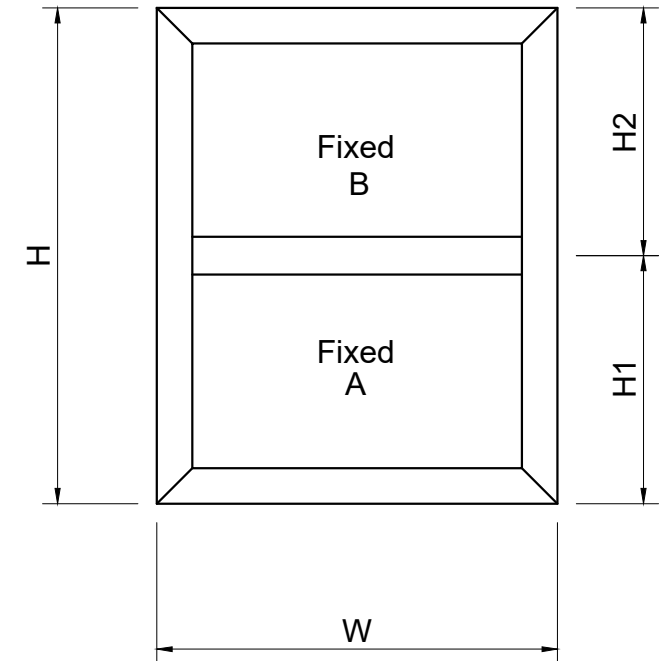
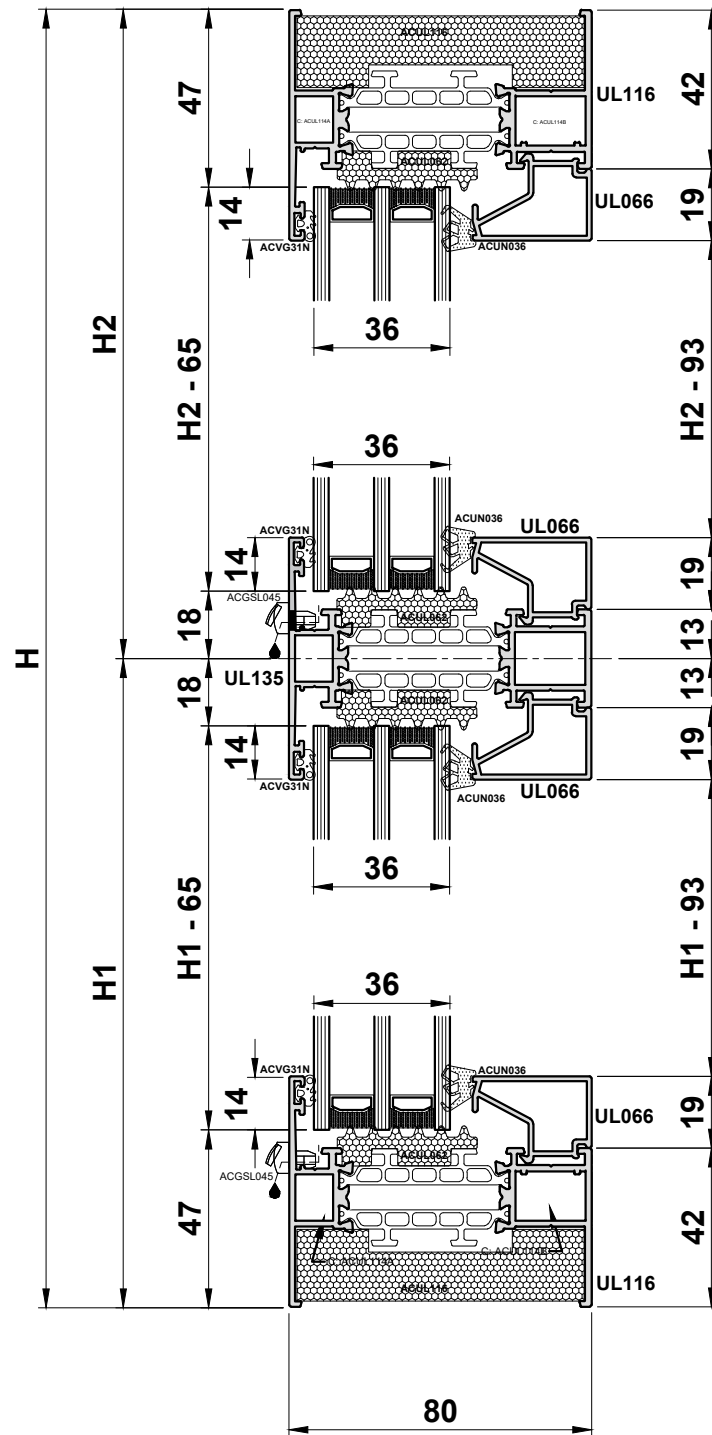





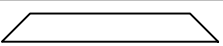

ACUN020	4	Corner Chevron
ACUL114A	4	Outerframe Cleat
ACUL114B	4	Outerframe Cleat
ACUL135	2	Transom Cleat
ACVL029	4	Strengthening Piece
ACVG31N	4 X W + 2 X H	E Gasket
ACUN036	4 X W + 2 X H	Wedge Gasket
ACGSL045	4	Drainage Cap
ACUL116	2 X (W+H)	Perimeter Foam

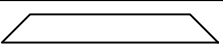

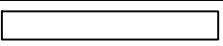
Do Not Scale From This Drawing

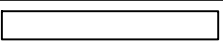
**Cutting Information**

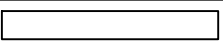
**Sections**

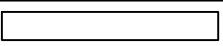
UL116		2		W
UL116		2		H
UL136		1		H-84
Bead		2		W1-58.5
Bead		2		W2-58.5
Bead		4		H-122

Glass	
A	W1 - 68.5 X H - 94
B	W2 - 68.5 X H - 94

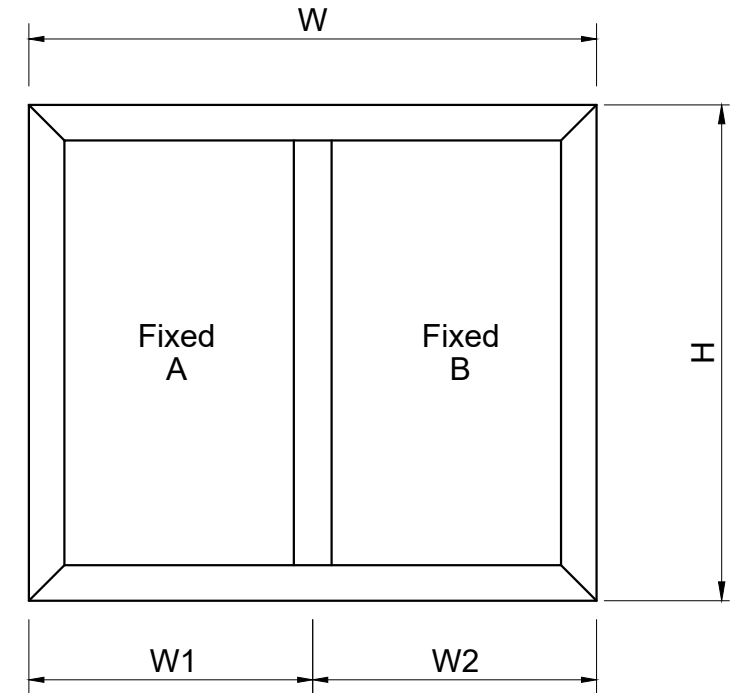

**Accessories**

ACUN020	4	Corner Chevron
ACUL114A	4	Outerframe Cleat
ACUL114B	4	Outerframe Cleat
ACUL136	2	Mullion Cleat
ACVL029	4	Strengthening Piece
ACVG31N	2 X W + 4 X H	E Gasket
ACUN036	2 X W + 4 X H	Wedge Gasket
ACGSL045	4	Drainage Cap
ACUL116	2 X (W+H)	Perimeter Foam

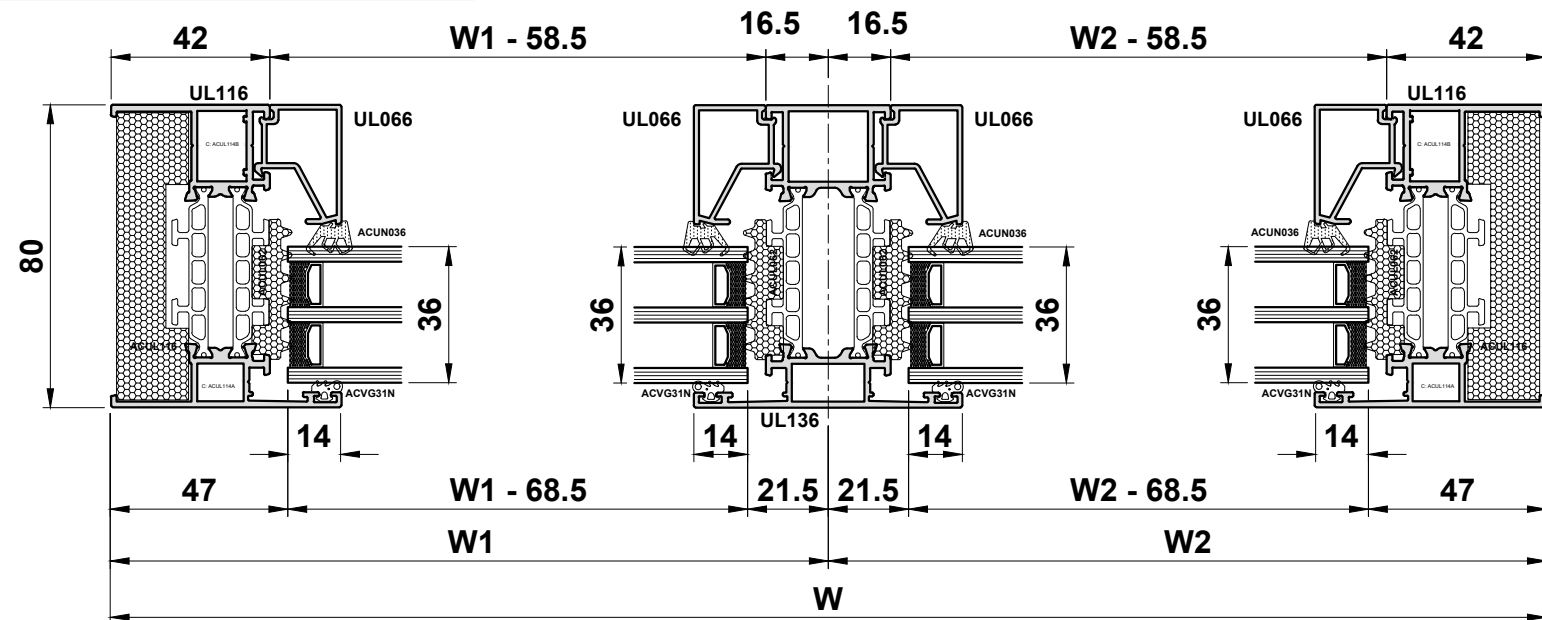
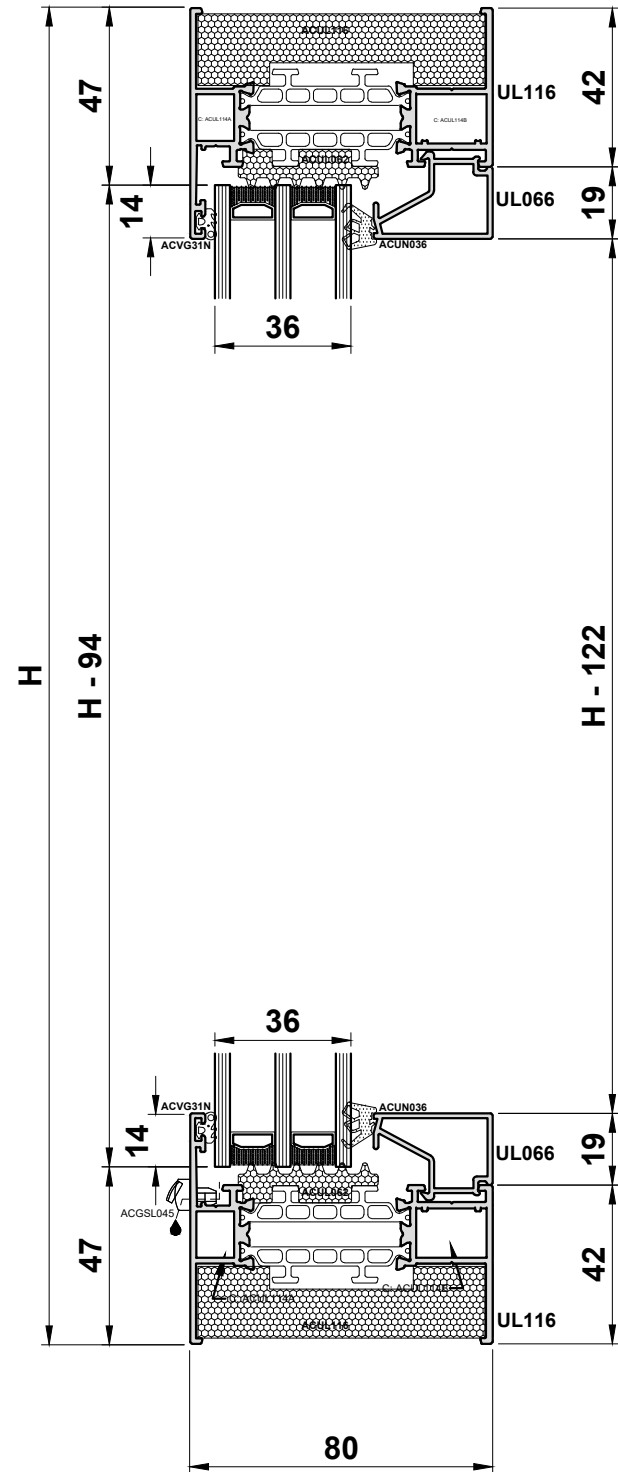

**Do Not Scale From This Drawing**

**Cutting Information**

Sections

UL116		2		W
UL116		2		H
UL125		2		W-74
UL125		2		H-74
Bead		2		W-179
Bead		2		H-217

Accessories

ACUN020	8	Corner Chevron
ACUL114A	4	Outerframe Cleat
ACUL114B	4	Outerframe Cleat
ACUL124	4	Sash Cleat
ACUL125A	4	Sash Cleat
ACW20131	2 X (W+H)	External Flat Gasket
ACGT060	2 X (W+H)	Central Gasket
ACGT160	4	Central Gasket Corner
ACGT062	2 X (W+H)	5mm Flipper Gasket
ACUL062	2 X (W+H)	Glazing Foam
ACVG31N	2 X (W+H)	E Gasket
ACUN036	2 X (W+H)	Wedge Gasket
ACGSL045	2	Drainage Cap
ACUL116	2 X (W+H)	Perimeter Foam

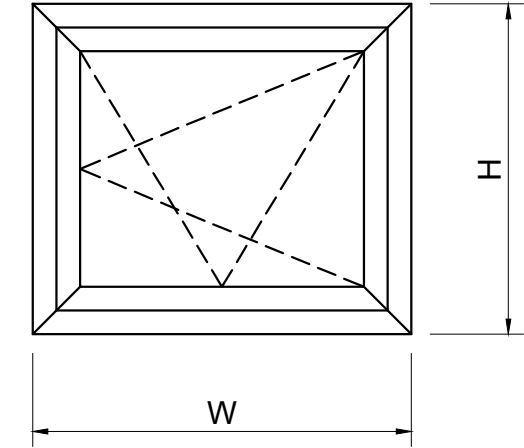

**Glass**  
**W - 189 X H - 189**

Please refer to the SB Chrono or Fapin manual for tilt & turn hardware.

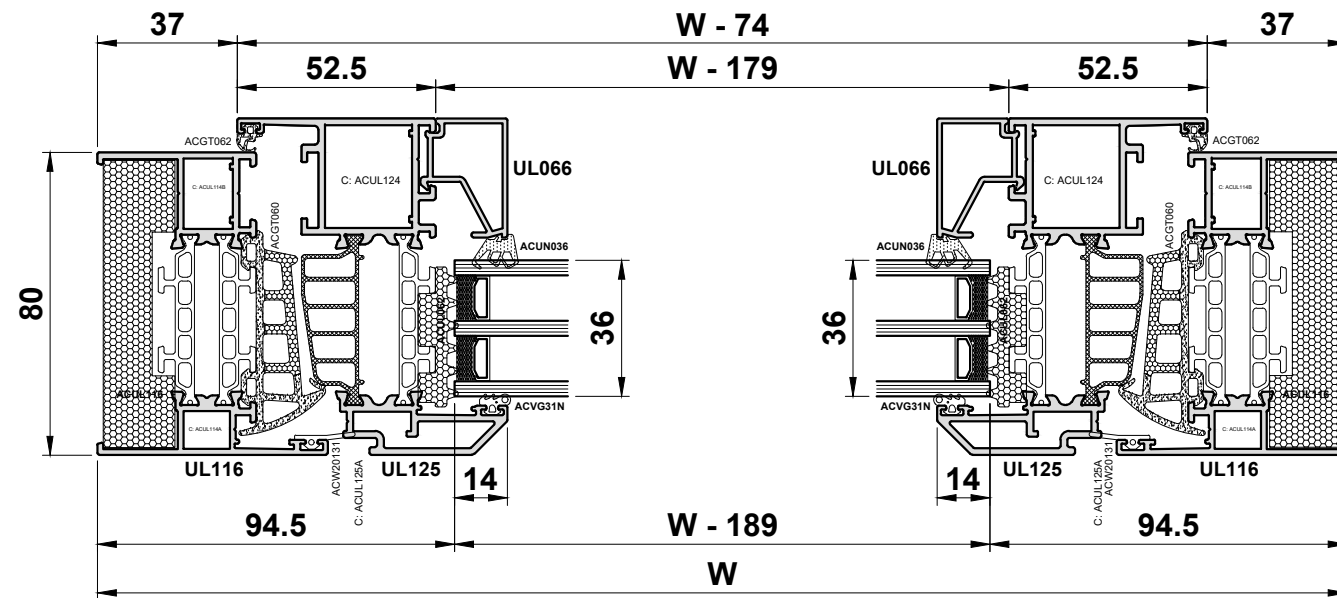
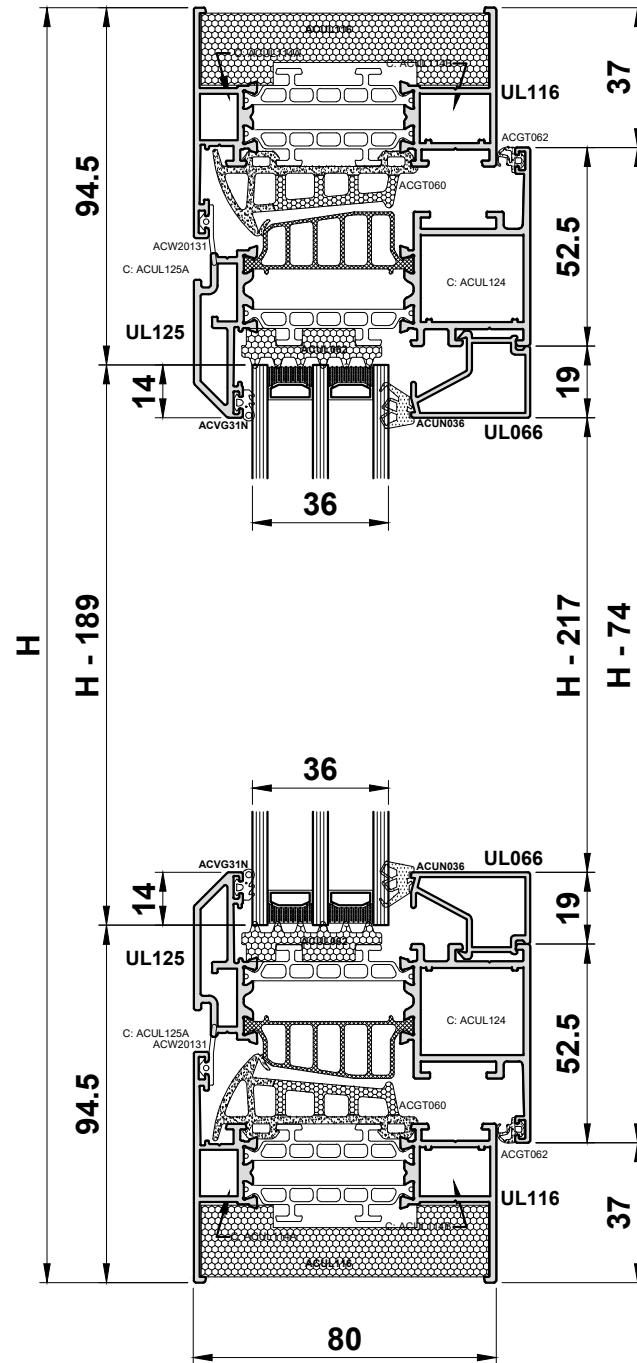

**Do Not Scale From This Drawing**

**Cutting Information**

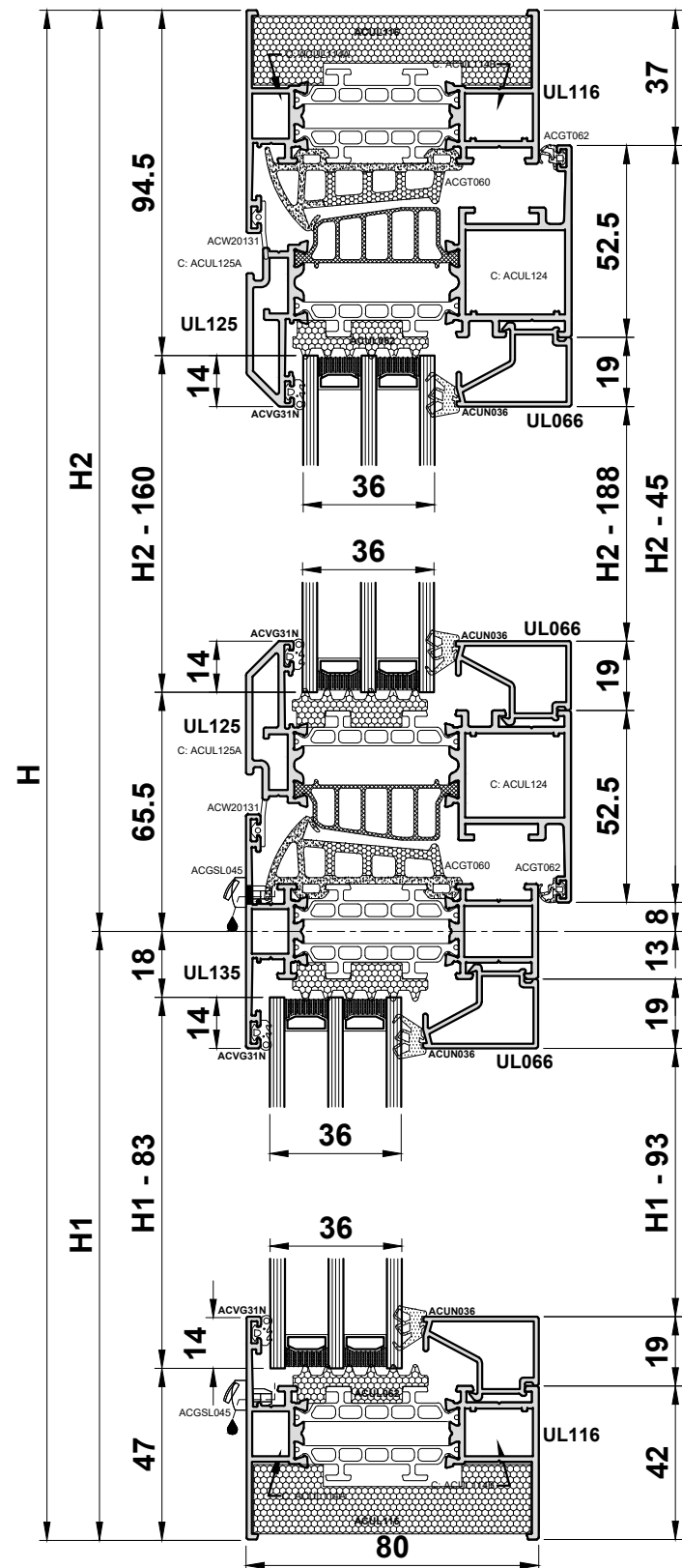

**Sections**

UL116		2		W
UL116		2		H
UL125		2		W-74
UL125		2		H2-45
UL135		1		W-84
Bead		2		W-179
Bead		2		W-84
Bead		2		H1-93
Bead		2		H2-188

**Glass**

A	W - 94 X H1 - 83
B	W - 189 X H2 - 160

**Accessories**

ACUN020	8	Corner Chevron
ACUL114A	4	Outerframe Cleat
ACUL114B	4	Outerframe Cleat
ACUL124	4	Sash Cleat
ACUL125A	4	Sash Cleat
ACUL135	2	Transom Cleat
ACVL029	4	Strengthening Piece
ACW20131	2 X (W+H2)	External Flat Gasket
ACGT060	2 X (W+H2)	Central Gasket
ACGT160	4	Central Gasket Corner
ACGT062	2 X (W+H2)	5mm Flipper Gasket
ACUL062	4 X W + 2 X H	Glazing Foam
ACVG31N	4 X W + 2 X H	E Gasket
ACUN036	4 X W + 2 X H	Wedge Gasket
ACGSL045	4	Drainage Cap
ACUL116	2 X (W+H)	Perimeter Foam

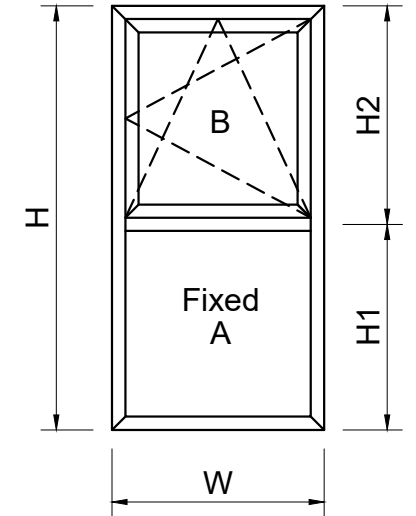

Please refer to the SB Chrono or Fapin manual for tilt & turn hardware.

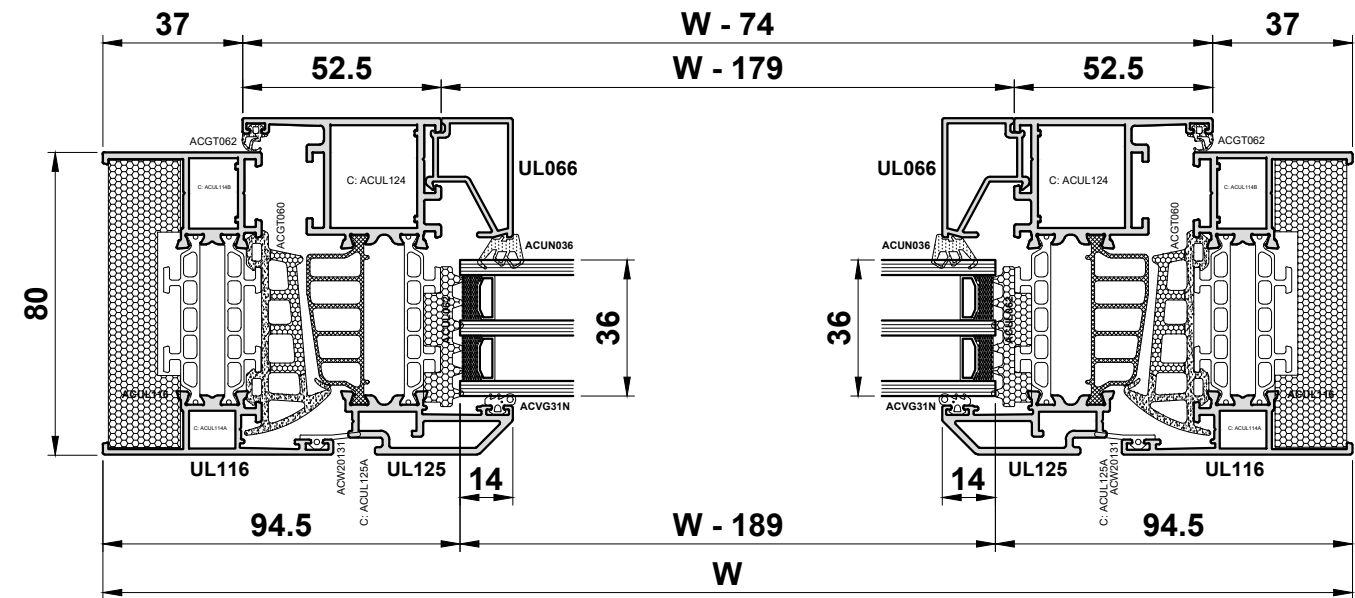

**Do Not Scale From This Drawing**

**Cutting Information**

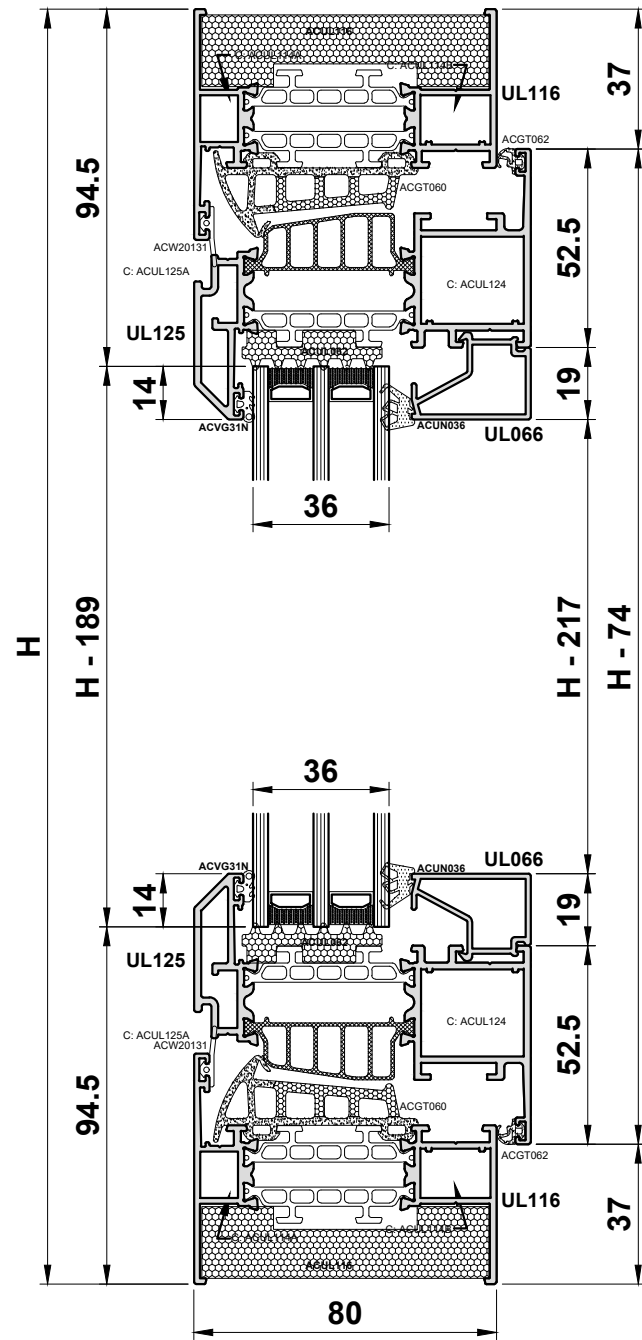

**Sections**

UL116		2		W
UL116		2		H
UL125		2		W1-48.5
UL125		2		W2-48.5
UL125		4		H-74
UL136		1		H-84
Bead		2		W1-153.5
Bead		2		W2-153.5
Bead		4		H-217

**Accessories**

ACUN020	12	Corner Chevron
ACUL114A	4	Outerframe Cleat
ACUL114B	4	Outerframe Cleat
ACUL124	8	Sash Cleat
ACUL125A	8	Sash Cleat
ACUL136	2	Mullion Cleat
ACVL029	4	Strengthening Piece
ACW20131	2 X W + 4 X H	External Flat Gasket
ACGT060	2 X W + 4 X H	Central Gasket
ACGT160	8	Central Gasket Corner
ACGT062	2 X W + 4 X H	5mm Flipper Gasket
ACUL062	2 X W + 4 X H	Glazing Foam
ACVG31N	2 X W + 4 X H	E Gasket
ACUN036	2 X W + 4 X H	Wedge Gasket
ACGSL045	4	Drainage Cap
ACUL116	2 X (W+H)	Perimeter Foam

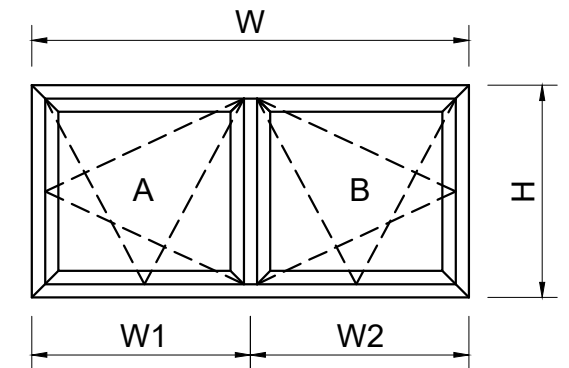

Glass	
A	W1 - 163.5 X H - 189
B	W2 - 163.5 X H - 189

Please refer to the SB Chrono or Fapin manual for tilt & turn hardware.

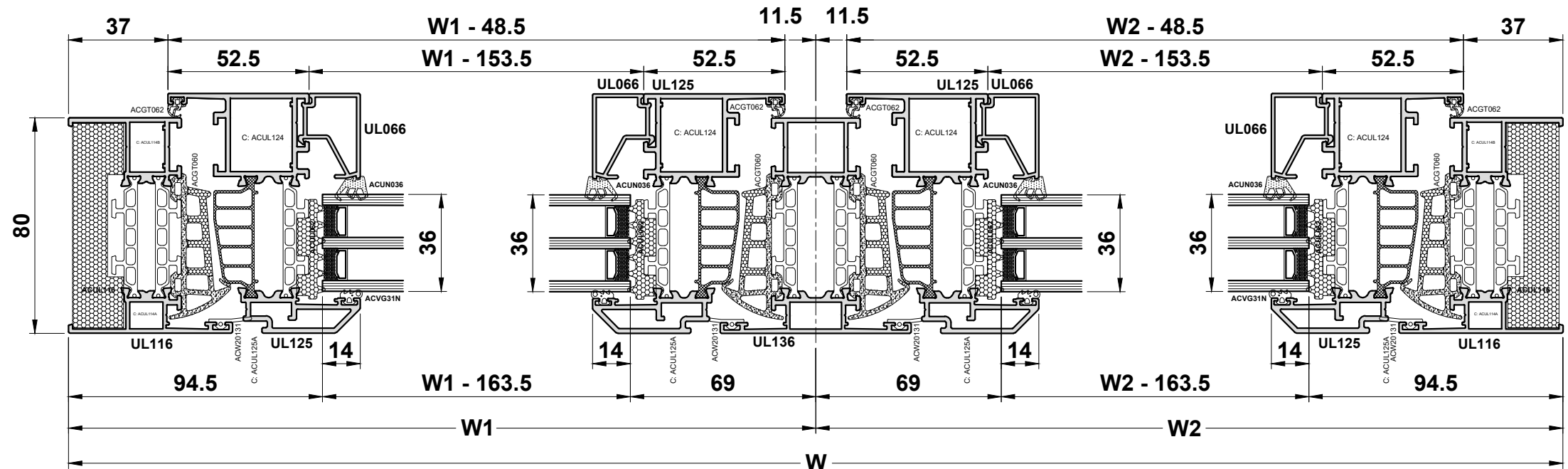

**Do Not Scale From This Drawing**