

Smart Systems Ltd
Signature Range Doors

Technical Guide

Version 2

May 2025



Index

Basic	01	Sectional Details	37
Size Limits & System Overview	02	Extras - Add ons	38
Door Handing	02	Extras - Couplers	38
Clear Opening - Width	03	Extras - Cills	39
Accessible Entrances	03	Extras - Trims	39
Door Clearance	04	Threshold Options	40
Hinge Clearance	04	Sectional Details	41 - 55
Designs	05	Maintenance	57
Design Information	06 - 13	Hardware	58
		Locks	58
Glass	15	Threshold & Seals	59
Clear Glass Specification	16	Paint	59
Satin Glass Specification	17	Glass	60
Hardware & Furniture	19	Notes	61
Locks - Standard Lift Lever	20	Contact Information	62
Locks - Premium Lift Lever	21		
Locks - Slam	22		
Locks - Split Spindle	23		
Locks - Heritage	24		
Hinge - 3D Adjustable	25		
Cylinders	26		
Architectural Handle Clearance	27		
Spyhole positions	27		
Cylinder Heights	28		
Midrail alignment	28		
Furniture Options	29		
Site Survey & Installation	31		
Site Survey - Dimensions	32		
Installation Guide	33		
De-Glaze Mouldings	34		
Re-Glaze Mouldings	35		

Basic

Size Limits & System Overview

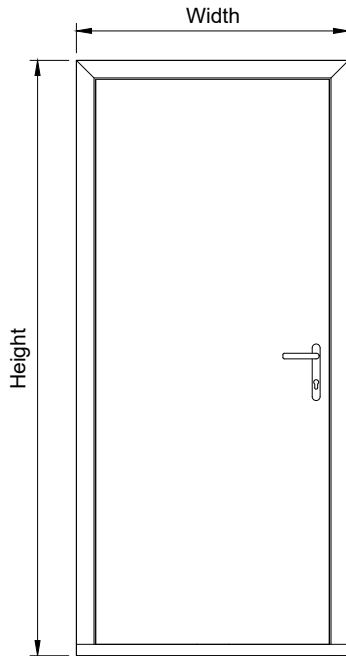

Size Limitations

- Minimum Width: 800mm
- Minimum Height: 1950mm
- Maximum Width: 1050mm
- Maximum Height: 2200mm



These sizes are overall door sizes excluding any frame extensions, add ons or cills and do not change based on threshold.

Threshold Options

- Standard Full Frame (FPR)
- 25mm Low Aluminium Threshold
- 15mm Low Aluminium Threshold (Part M)

Weights

- Doors range between 30kg - 55kg

Glass

- Great performance low-emissivity (low-E)
- P1A - required for PAS24
- Centrepane of 1.0 W/m²K

Door Handing

VIEWED FROM OUTSIDE OPEN IN

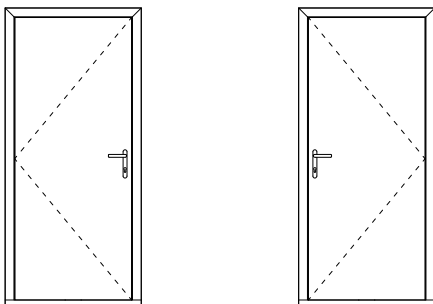

LEFT HAND HUNG
KEEP = RIGHT HAND

RIGHT HAND HUNG
KEEP = LEFT HAND

VIEWED FROM OUTSIDE OPEN OUT

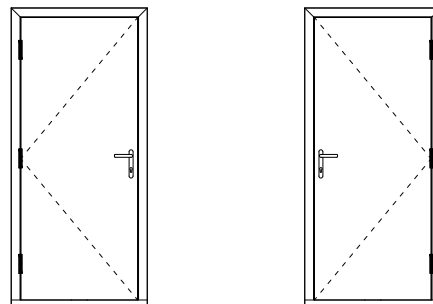

LEFT HAND HUNG
KEEP = LEFT HAND

RIGHT HAND HUNG
KEEP = RIGHT HAND

Clear Opening

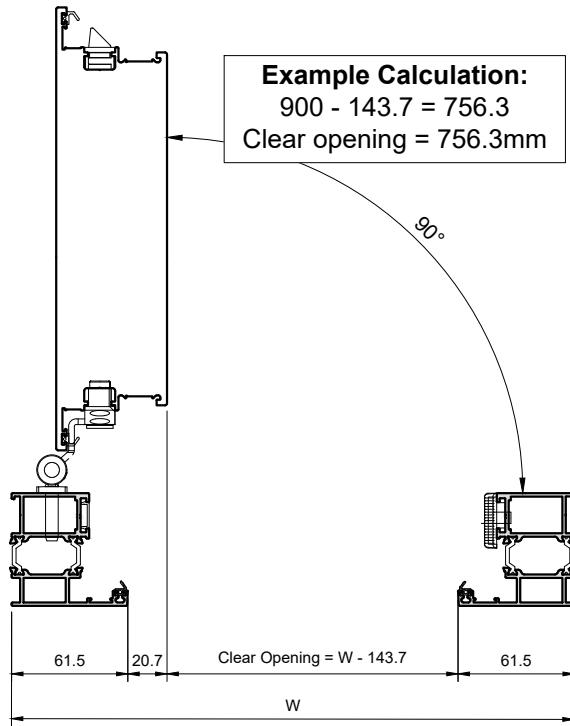

Clear Opening is the size of the gap any persons/objects can pass through freely when the door is opened to its full potential. Please consider hardware when calculating clear opening.

Signature Doors are able to open past 90°.

If the door opens to more than 90°, door furniture may not obstruct the clear opening width.

Clear Opening = Width* - 143.7mm

*Width is calculated from edge of outerframe to edge of outerframe, not inclusive of frame extensions.

Accessible Entrances - Approved Document M

Signature Doors are now available with an accessible threshold meeting Approved Document M requirements.

Approved Document M is a UK building regulation that provides guidance on ensuring buildings are accessible and usable by all, including those with disabilities. It outlines requirements for dwellings and other buildings to have features such as accessible entrances.

Please read latest Approved Document M to ensure all requirements are met for your specified project.

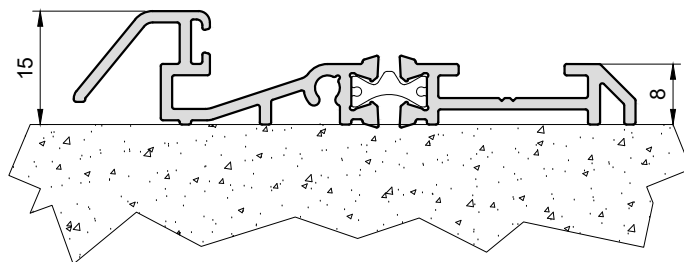

*Non-standard Door access control height, to be confirmed for each door. May incur additional charges.

Category 1: Visitable Dwellings (New Builds)

- Clear Opening \geq 775mm
- Accessible Threshold

Category 2: Accessible and Adaptable Dwellings

- Clear Opening: \geq 850mm
- Accessible Threshold
- Door Access Control height: 900 - 1000mm*

Category 3: Wheelchair User Dwelling

- Clear Opening \geq 850mm
- Accessible Threshold
- Door Access Control height: 900 - 1000mm*

Door Clearance

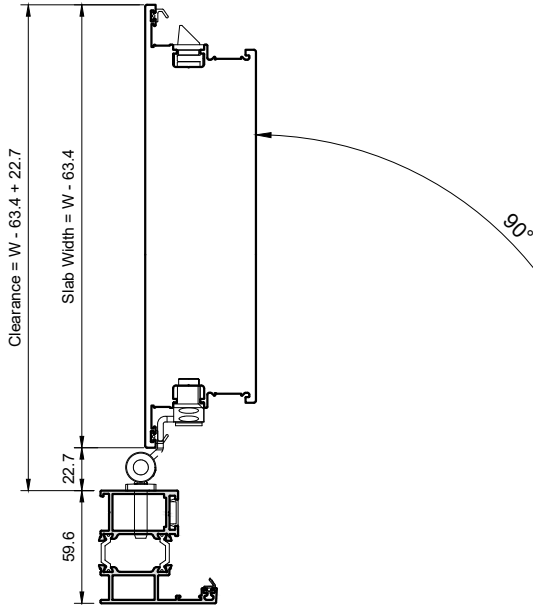

Clearance is the distance between the face of the outerframe to the edge of the slab when the door is open to 90°.

$$\text{Clearance} = \text{Width}^* - 63.4 + 22.7$$

*Width is calculated from edge of outerframe to edge of outerframe, not inclusive of frame extensions.

Example Calculation:

$$900 - 63.4 + 22.7 = 859.3$$

$$\text{Clearance} = 859.3\text{mm}$$

Hinge Clearance

Hinge clearance refers to the space required around the hinges to allow for proper operation of the door.

Hinge clearance is necessary for a few reasons:

1. Avoiding contact with the plaster line or wall: The hinge side of a door should have enough clearance to prevent the hinges from coming into contact with internal finishes.
2. Ensuring smooth operation: Sufficient hinge clearance allows the door to open and close smoothly without any binding or resistance.

ETC557 Add on provides an additional 20mm of hinge clearance.

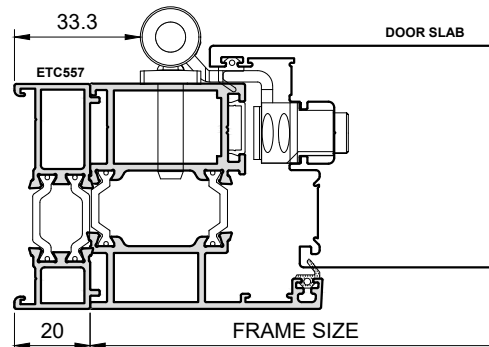
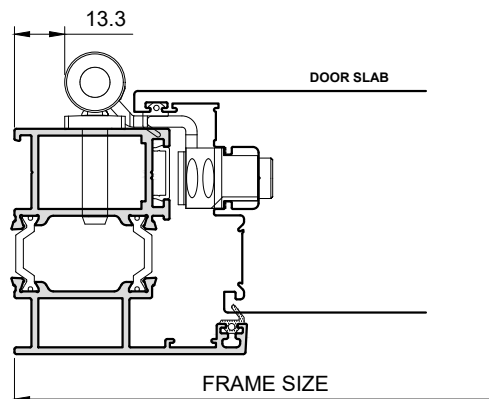

Designs

Designs

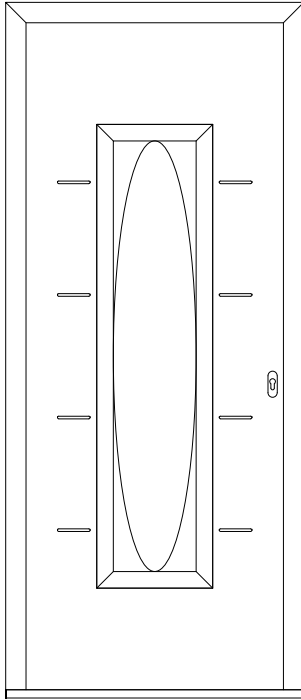

DM3001 - CARNABY

U-Value: 1.3W/m²K*

Glass Thickness: 28.8mm

Moulding Shape: A - Rounded

Trims: N/A

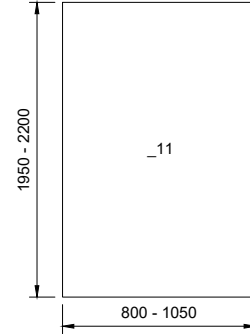

Variant	Moulding Size	Glass Size	Visible Glass
_11	350mm x 1400mm	284mm x 1334mm	250mm x 1300mm

Based on Open In 25mm Low Aluminium Threshold. At a minimum, all doors can acheive 1.4 W/m²K

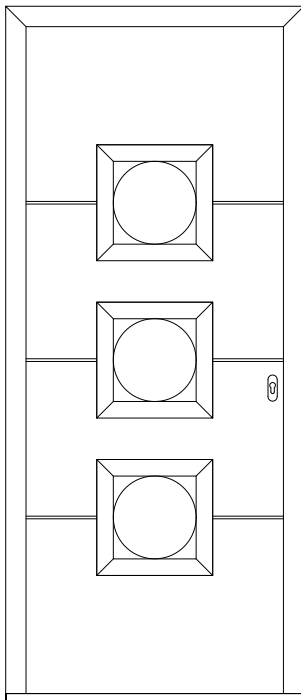

DM3002 - LANSDOWN

U-Value: 1.3W/m²K*

Glass Thickness: 28.8mm

Moulding Shape: A - Rounded

Trims: N/A

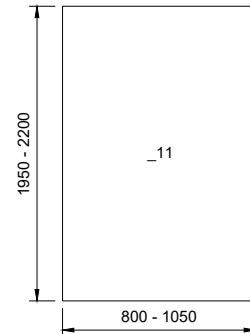

Variant	Moulding Size	Glass Size	Visible Glass
_11	350mm x 350mm	284mm x 284mm	250mm x 250mm

Based on Open In 25mm Low Aluminium Threshold,. At a minimum, all doors can acheive 1.4 W/m²K

Designs

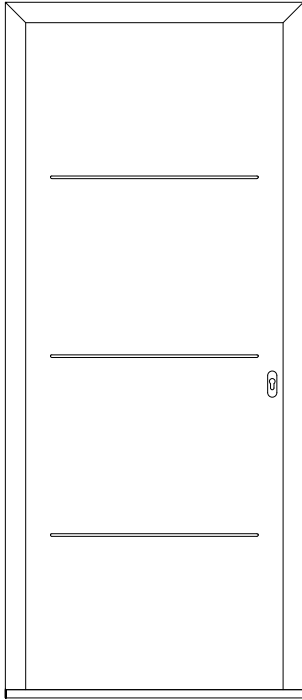

DM3003 - MILLBROOK

U-Value: 1.2W/m²K*
Glass Thickness: N/A
Moulding Shape: N/A
Trims: N/A

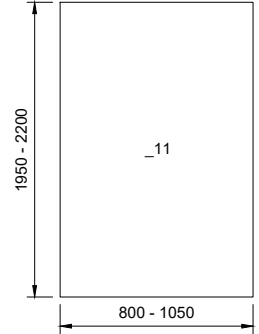

Variant	Moulding Size	Glass Size	Visible Glass

Based on Open In 25mm Low Aluminium Threshold,. At a minimum, all doors can acheive 1.4 W/m²K

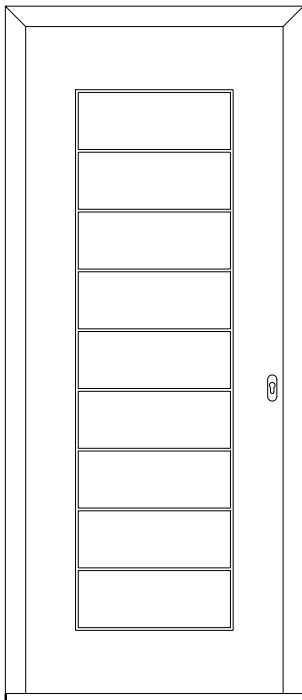

DM3004 - PORTOBELLO

U-Value: 1.2W/m²K*
Glass Thickness: N/A
Moulding Shape: N/A
Trims: N/A

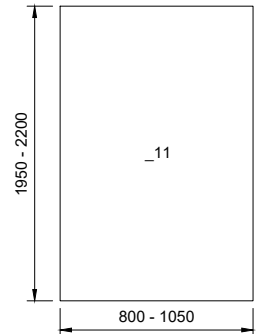

Variant	Moulding Size	Glass Size	Visible Glass

Based on Open In 25mm Low Aluminium Threshold,. At a minimum, all doors can acheive 1.4 W/m²K

Designs

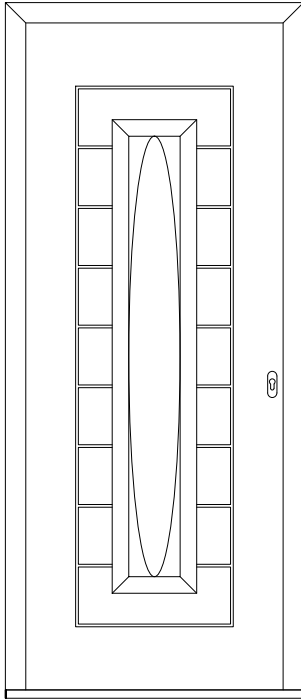

DM3005 - PORTOBELLO FULL GLAZED

U-Value: 1.3W/m²K*

Glass Thickness: 28.8mm

Moulding Shape: A - Rounded

Trims: N/A

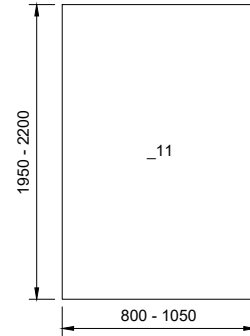

Variant	Moulding Size	Glass Size	Visible Glass
_11	255mm x 1430mm	189mm x 1364mm	155mm x 1330mm

*Based on Open In 25mm Low Aluminium Threshold,. At a minimum, all doors can acheive 1.4 W/m²K

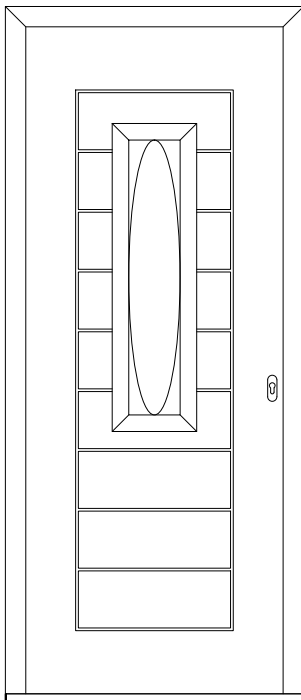

DM3006 - PORTOBELLO HALF GLAZED

U-Value: 1.3W/m²K*

Glass Thickness: 28.8mm

Moulding Shape: A - Rounded

Trims: N/A

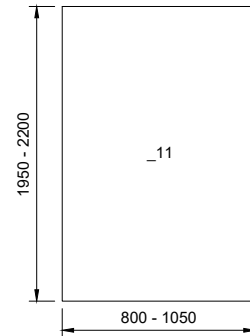

Variant	Moulding Size	Glass Size	Visible Glass
_11	255mm x 930mm	189mm x 864mm	155mm x 830mm

*Based on Open In 25mm Low Aluminium Threshold,. At a minimum, all doors can acheive 1.4 W/m²K

Designs

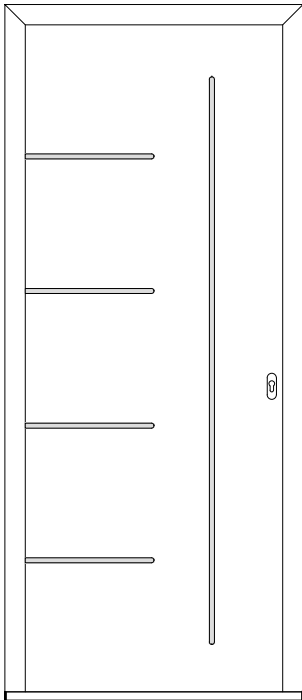

DM3007 - GRAINGER

U-Value: 1.2W/m²K^{*}
Glass Thickness: N/A
Moulding Shape: N/A
Trims: Silver Anodised

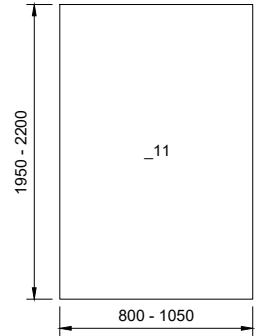

Variant	Moulding Size	Glass Size	Visible Glass

Based on Open In 25mm Low Aluminium Threshold,. At a minimum, all doors can acheive 1.4 W/m²K

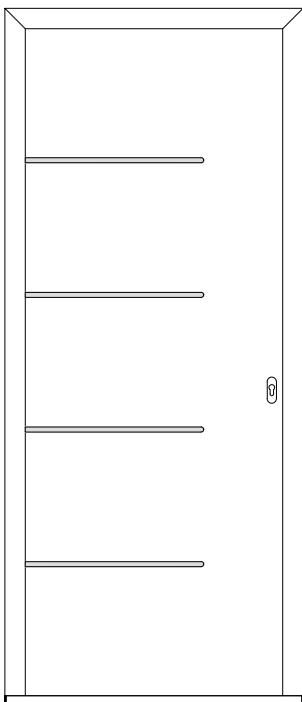

DM3008 - PICTON

U-Value: 1.2W/m²K^{*}
Glass Thickness: N/A
Moulding Shape: N/A
Trims: Silver Anodised

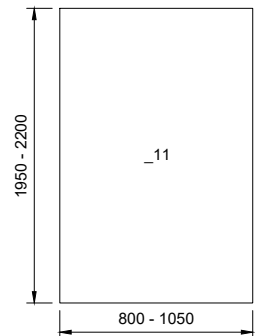

Variant	Moulding Size	Glass Size	Visible Glass

Based on Open In 25mm Low Aluminium Threshold,. At a minimum, all doors can acheive 1.4 W/m²K

Designs

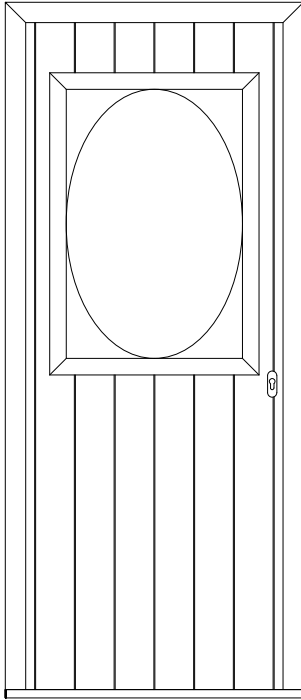

DT3001 - WOODCHESTER

U-Value: 1.4W/m²K*

Glass Thickness: 28.8mm

Moulding Shape: A - Rounded

Trims: N/A

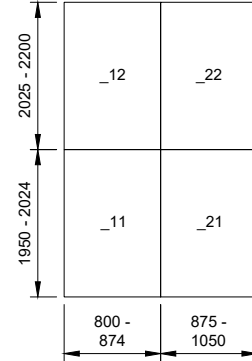

Variant	Moulding Size	Glass Size	Visible Glass
_11	532mm x 850mm	466mm x 784mm	432mm x 750mm
_21	632mm x 850mm	566mm x 784mm	532mm x 750mm
_12	532mm x 912mm	466mm x 846mm	432mm x 812mm
_22	632mm x 912mm	566mm x 846mm	532mm x 812mm

Based on Open In 25mm Low Aluminium Threshold, . At a minimum, all doors can acheive 1.4 W/m²K

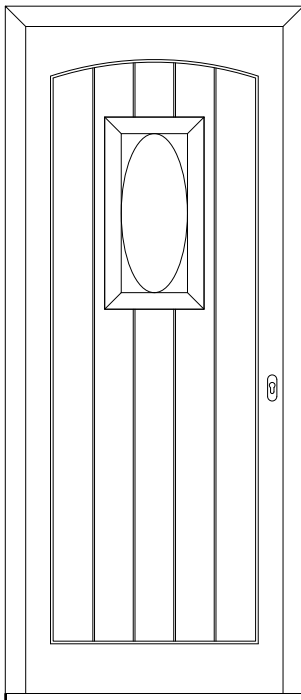

DT3002 - BROADFIELD

U-Value: 1.3W/m²K*

Glass Thickness: 28.8mm

Moulding Shape: A - Rounded

Trims: N/A

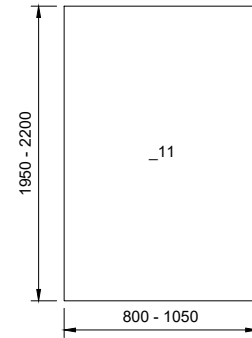

Variant	Moulding Size	Glass Size	Visible Glass
_11	300mm x 580mm	234mm x 514mm	200mm x 480mm

Based on Open In 25mm Low Aluminium Threshold, . At a minimum, all doors can acheive 1.4 W/m²K

Designs

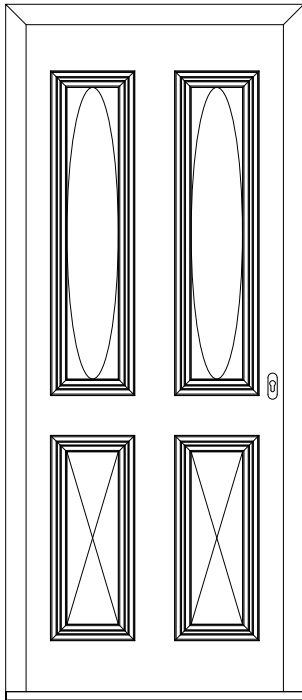

DT3003 - HARLEY

U-Value: 1.4W/m²K*

Glass Thickness: 28.8mm

Moulding Shape: C - Ovolo

Trims: N/A

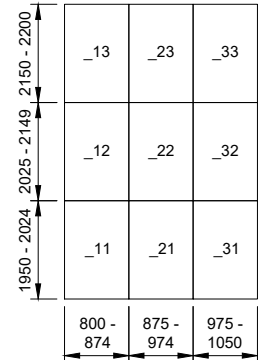

Variant	Moulding Size	Glass Size	Visible Glass
_11	225mm x 930mm	159mm x 864mm	125mm x 830mm
_21	255mm x 930mm	189mm x 864mm	155mm x 830mm
_31	285mm x 930mm	219mm x 864mm	185mm x 830mm
_12	225mm x 980mm	159mm x 914mm	125mm x 880mm
_22	255mm x 980mm	189mm x 914mm	155mm x 880mm
_32	285mm x 980mm	219mm x 914mm	185mm x 880mm
_13	225mm x 1030mm	159mm x 964mm	125mm x 930mm
_23	255mm x 1030mm	189mm x 964mm	155mm x 930mm
_33	285mm x 1030mm	219mm x 964mm	185mm x 930mm

Based on Open In 25mm Low Aluminium Threshold, . At a minimum, all doors can acheive 1.4 W/m²K

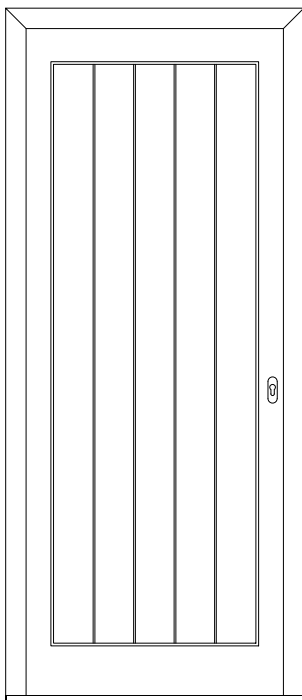

DT3004 - ABBEY

U-Value: 1.2W/m²K*

Glass Thickness: N/A

Moulding Shape: N/A

Trims: N/A

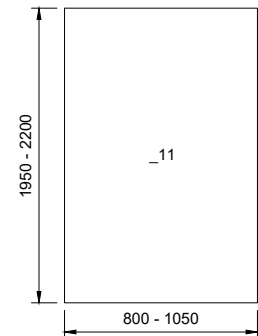

Variant	Moulding Size	Glass Size	Visible Glass

Based on Open In 25mm Low Aluminium Threshold, . At a minimum, all doors can acheive 1.4 W/m²K

Designs

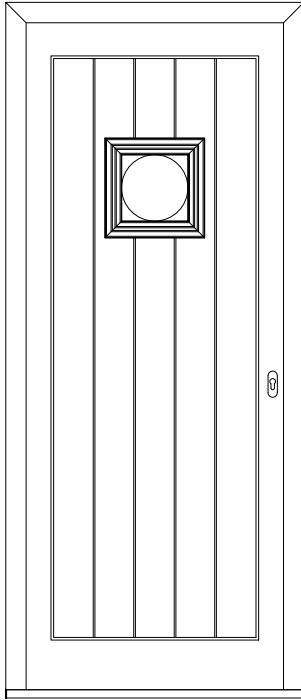

DT3005 - ABBEY SQUARE

U-Value: 1.3W/m²K*

Glass Thickness: 28.8mm

Moulding Shape: C - Ovolo

Trims: N/A

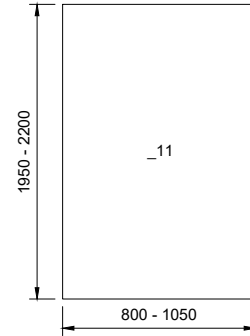

Variant	Moulding Size	Glass Size	Visible Glass
_11	300mm x 300mm	234mm x 234mm	200mm x 200mm

*Based on Open In 25mm Low Aluminium Threshold,. At a minimum, all doors can acheive 1.4 W/m²K

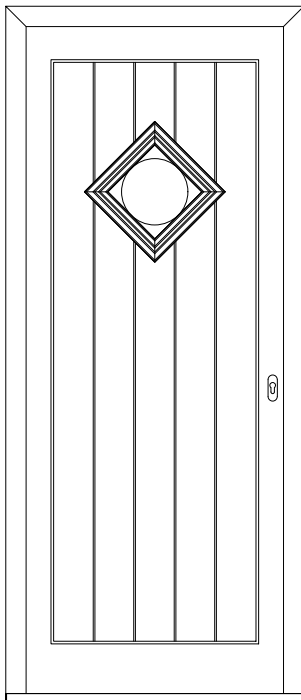

DT3006 - ABBEY DIAMOND

U-Value: 1.3W/m²K*

Glass Thickness: 28.8mm

Moulding Shape: C - Ovolo

Trims: N/A

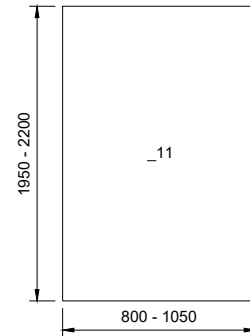

Variant	Moulding Size	Glass Size	Visible Glass
_11	300mm x 300mm	234mm x 234mm	200mm x 200mm

*Based on Open In 25mm Low Aluminium Threshold,. At a minimum, all doors can acheive 1.4 W/m²K

Designs

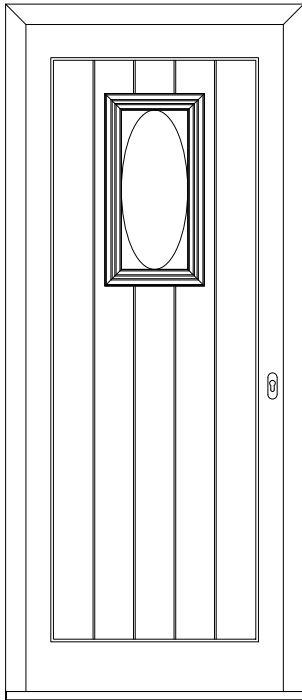

DT3007 - ABBEY RECTANGLE

U-Value: 1.3W/m²K*
Glass Thickness: 28.8mm
Moulding Shape: C - Ovolo
Trims: N/A

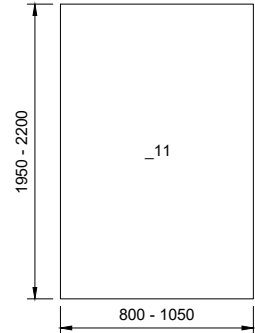

Variant	Moulding Size	Glass Size	Visible Glass
_11	300mm x 580mm	234mm x 514mm	200mm x 480mm

Based on Open In 25mm Low Aluminium Threshold,. At a minimum, all doors can acheive 1.4 W/m²K

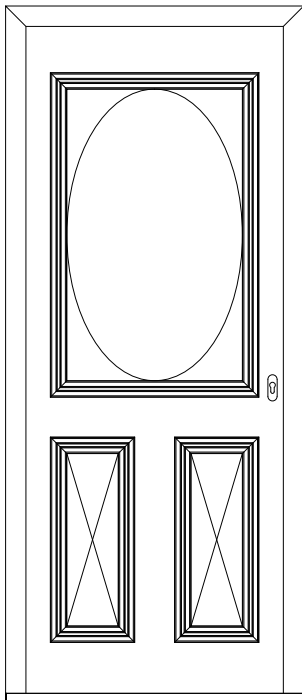

DT3008 - BAKER

U-Value: 1.4W/m²K*
Glass Thickness: 28.8mm
Moulding Shape: C - Ovolo
Trims: N/A

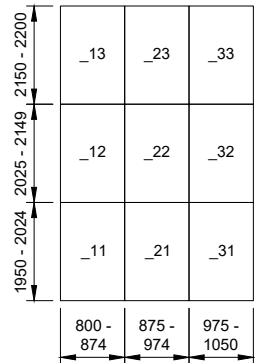

Variant	Moulding Size	Glass Size	Visible Glass
_11	570mm x 930mm	504mm x 864mm	470mm x 830mm
_21	630mm x 930mm	564mm x 864mm	530mm x 830mm
_31	690mm x 930mm	624mm x 864mm	590mm x 830mm
_12	570mm x 980mm	504mm x 914mm	470mm x 880mm
_22	630mm x 980mm	564mm x 914mm	530mm x 880mm
_32	690mm x 980mm	624mm x 914mm	590mm x 880mm
_13	570mm x 1030mm	504mm x 964mm	470mm x 930mm
_23	630mm x 1030mm	564mm x 964mm	530mm x 930mm
_33	690mm x 1030mm	624mm x 964mm	590mm x 930mm

Based on Open In 25mm Low Aluminium Threshold,. At a minimum, all doors can acheive 1.4 W/m²K

BLANK PAGE

Glass

Clear Glazing 28.8mm

28.8mm Clear Double Glazed Unit (Low-E)

- Pane 1: 6.8mm Clear Laminate
- Cavity: 18mm Black Spacer 90% Argon
- Pane 2: 4mm Toughened Planitherm One T FG

Solar Factors EN410 (2011-04)

- Solar Factor (g) 0.46
- Shading Coefficient (SC) 0.53

Thermal Transmission (Ug) EN673-2011

- Ug 1.0 W/(m2.K)
- 0° related to a vertical position

Burglar Resist EN356

- Result : P1A / NPD

Carbon Footprint EN15804 + A2

- Global Warming Potential: 46 kg(CO2)/m² (A1-A3)

Manufacturing Sizes

- Nominal Thickness: 28.8mm
- Weight: 26 kg/m²

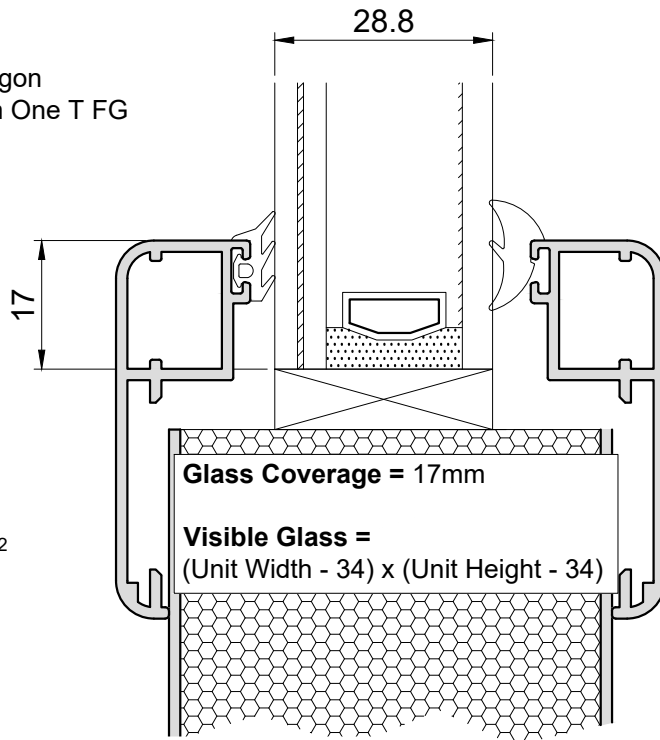

FULL DATA SHEET AVAILABLE ON REQUEST

Clear Glazing 29.6mm

29.6mm Clear Double Glazed Unit (Low-E)

- Pane 1: 6.8mm Clear Laminate
- Cavity: 16mm Black Spacer 90% Argon
- Pane 2: 6.8mm Clear Laminate Planitherm One T FG

Solar Factors EN410 (2011-04)

- Solar Factor (g) 0.46
- Shading Coefficient (SC) 0.53

Thermal Transmission (Ug) EN673-2011

- Ug 1.0 W/(m2.K)
- 0° related to a vertical position

Burglar Resist EN356

- Result : P1A / P1A

Carbon Footprint EN15804 + A2

- Global Warming Potential: 59 kg(CO2)/m² (A1-A3)

Manufacturing Sizes

- Nominal Thickness: 29.5mm
- Weight: 31.6 kg/m²

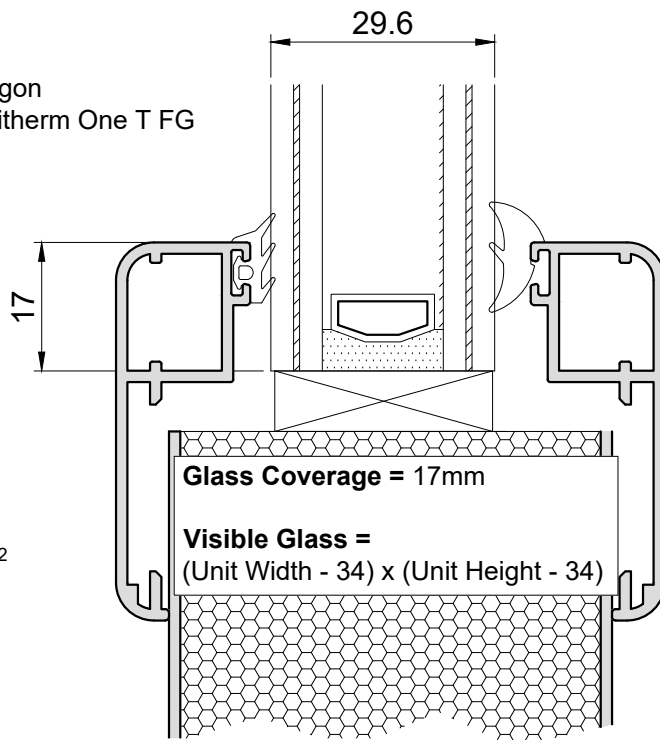

FULL DATA SHEET AVAILABLE ON REQUEST

Satin Glazing 28.8mm

28.8mm Satin Double Glazed Unit (Low-E)

- Pane 1: 6.8mm Diffused Laminate
- Cavity: 18mm Black Spacer 90% Argon
- Pane 2: 4mm Toughened Planitherm One T FG

Solar Factors EN410 (2011-04)

- Solar Factor (g) 0.46
- Shading Coefficient (SC) 0.53

Thermal Transmission (Ug) EN673-2011

- Ug 1.0 W/(m2.K)
- 0° related to a vertical position

Burglar Resist EN356

- Result : P1A / NPD

Carbon Footprint EN15804 + A2

- Global Warming Potential: 46 kg(CO₂)/m² (A1-A3)

Manufacturing Sizes

- Nominal Thickness: 28.8mm
- Weight: 26 kg/m²

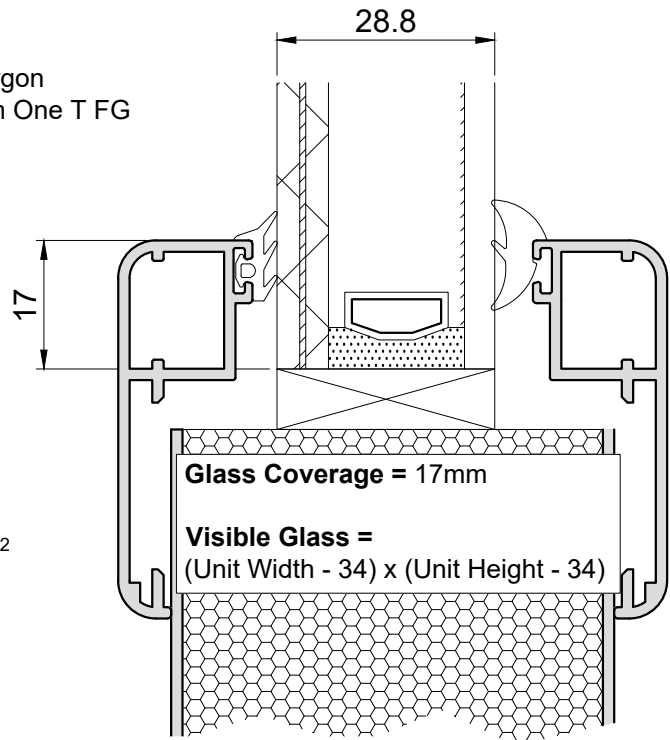

FULL DATA SHEET AVAILABLE ON REQUEST

Satin Glazing 29.6mm

29.6mm Satin Double Glazed Unit (Low-E)

- Pane 1: 6.8mm Diffused Laminate
- Cavity: 16mm Black Spacer 90% Argon
- Pane 2: 6.8mm Clear Laminate Planitherm One T FG

Solar Factors EN410 (2011-04)

- Solar Factor (g) 0.46
- Shading Coefficient (SC) 0.53

Thermal Transmission (Ug) EN673-2011

- Ug 1.0 W/(m2.K)
- 0° related to a vertical position

Burglar Resist EN356

- Result : P1A / P1A

Carbon Footprint EN15804 + A2

- Global Warming Potential: 59 kg(CO₂)/m² (A1-A3)

Manufacturing Sizes

- Nominal Thickness: 29.5mm
- Weight: 31.6 kg/m²

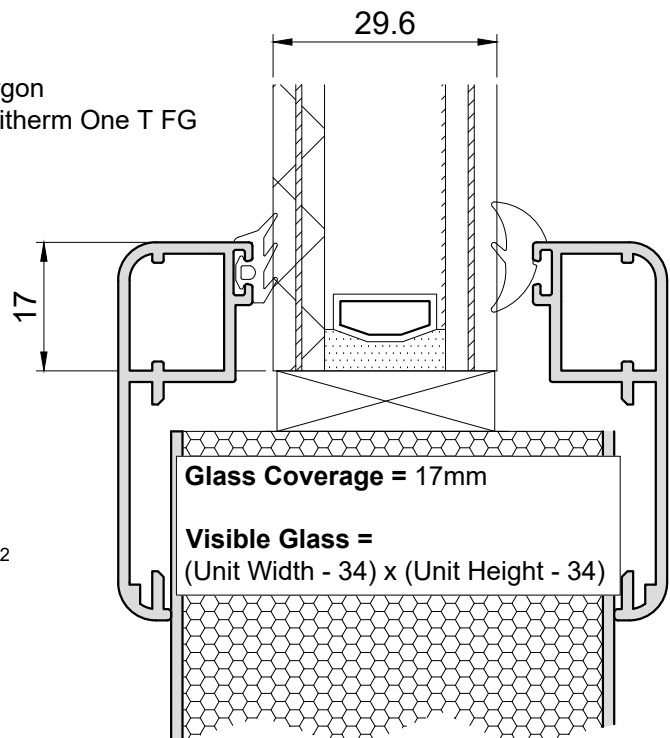

FULL DATA SHEET AVAILABLE ON REQUEST

BLANK PAGE

Hardware & Furniture

Standard Lift Lever Lock

Key Features of Cam Lift Lever Lock are:

- Sturdy steel hook bolts
- Nickel-plated latch for smooth closure
- Rugged main deadbolt
- Adjustable compression cams with brass rollers
- Classic lift lever operation
- Adjustable (+/- 2mm) latch keep
- PAS24:2022 compliant
- 35mm lock backset

Operation:

Lift handle lever to throw hooks and compression cams into locked position. Turn key or thumbturn to lock.

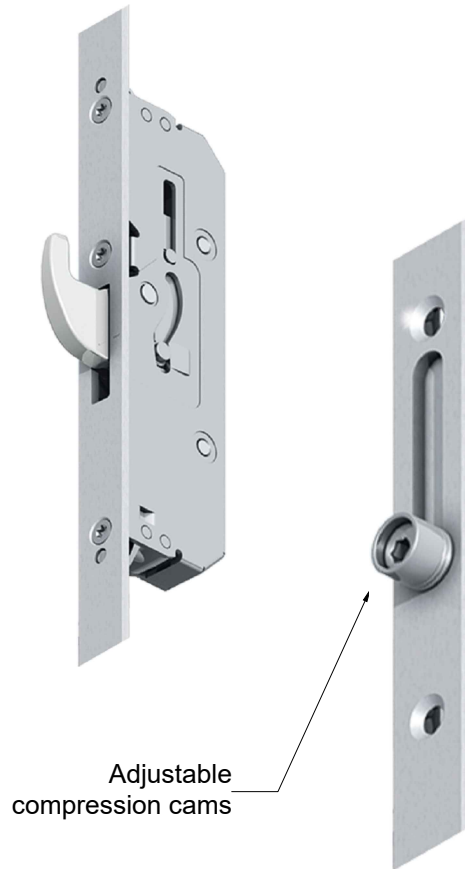

		Lock	Keep	
			LH	RH
Size	Short	ACUL275	ACUL270	ACUL271
	Standard	ACUL379	ACUL371	ACUL372

IMPORTANT NOTE:

Door height \geq 2019mm use Standard locks
Door height $<$ 2019mm use Short locks

Details

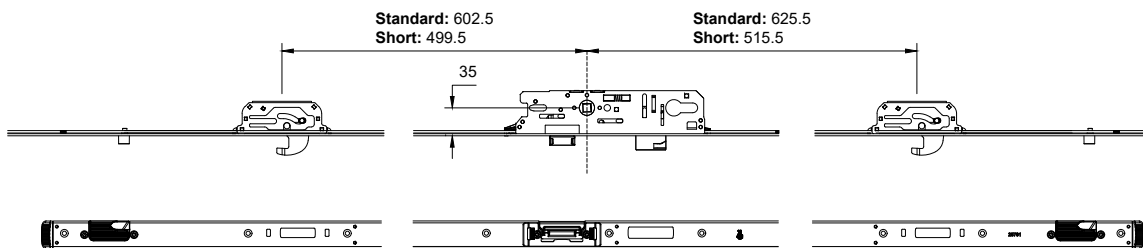

Spindle Height: 1050mm from FFL
Cylinder Height: 958mm from FFL

Premium Lift Lever Lock

Key Features of Premium Lift Lever Lock are:

- Sturdy steel hook bolts
- Bank Vault style dual round security bolts
- Adjustable (+/- 2mm) locking box keeps
- Adjustable (+/- 2mm) latch keep
- Classic lift lever operation
- PAS24:2022 compliant
- 35mm lock backset

Operation:

Lift handle lever to throw hooks and pins into locked position. Turn key or thumbturn to lock.



		Lock	Keep	
			LH	RH
Size	Short	ACUL376	ACUL391	ACUL393
	Standard	ACUL298	ACUL288	ACUL289

IMPORTANT NOTE:

Door height \geq 2019mm use Standard locks
Door height $<$ 2019mm use Short locks

Details

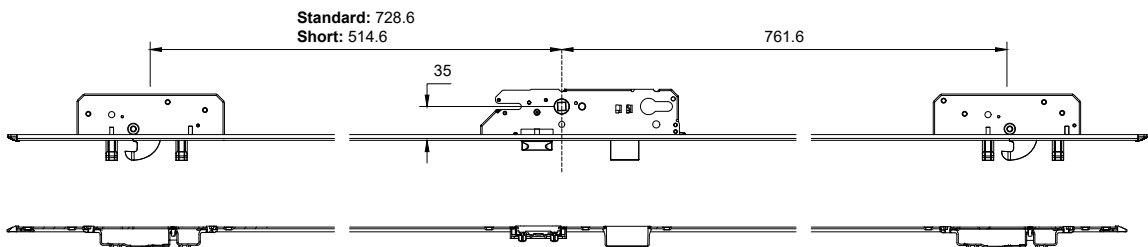

Spindle Height: 1050mm from FFL
Cylinder Height: 958mm from FFL

Slam Lock

Key Features of Slam Lock are:

- DuoSecure - Increased Security
- Sturdy steel hook bolts
- Enhanced Security Pin
- Adjustable (+/- 2mm) locking box keeps
- Adjustable (+/- 2mm) latch keep
- Automatic locking on close
- PAS24:2022 compliant
- 35mm lock backset

Operation:

On shutting door, hooks will automatically throw into locked position (activated by the magnet on the keep). Use Key or Thumbturn to throw deadbolt. Cylinder and/or Handle operation is required to unlock door.

11mm strong latching bolt keeps the door in position and ensures contact pressure

the hook bolt ensures security

The wide lock box allows for smooth operation of hook bolt

Tamper proof and dirt resistant magnetic release



IMPORTANT NOTE:
Each Slam Lock Keep will require
2no ACUL286 - Release magnet

Size	Lock	Keep	
		LH	RH
Short	ACUL386	ACUL391	ACUL393
Standard	ACUL285	ACUL288	ACUL289

IMPORTANT NOTE:
Door height \geq 2019mm use Standard locks
Door height $<$ 2019mm use Short locks

Details

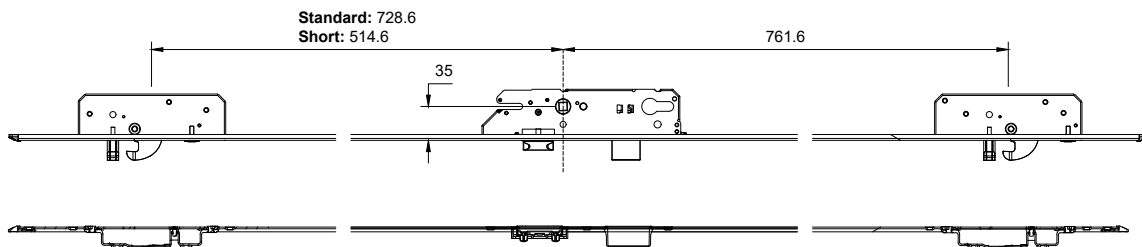

Spindle Height: 1050mm from FFL
Cylinder Height: 958mm from FFL

Split Spindle Lock

Key Features of Split Spindle Lock are:

- Sturdy steel hook bolts
- Nickel-plated latch for smooth closure
- Rugged main deadbolt
- Adjustable compression cams with brass rollers
- Classic Split Spindle operation
- Adjustable (+/- 2mm) latch keep
- PAS24:2022 compliant
- Key required to open door from outside.
- 35mm lock backset

Operation:

Lift handle lever/pad to throw hooks and compression cams into locked position. Key required to open door from outside. Turn key or thumbturn to lock.



IMPORTANT NOTE:
Each Split Spindle Lock will require
1no ACUL414 - Split Spindle Kit

IMPORTANT NOTE:
Door height \geq 2019mm use Standard locks
Door height $<$ 2019mm use Short locks

		Lock	Keep	
			LH	RH
Size	Short	n/a	n/a	n/a
	Standard	ACUL413	ACUL371	ACUL372

Details

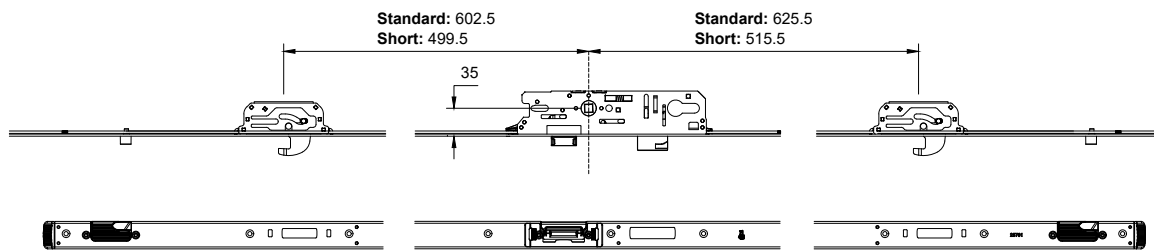

Spindle Height: 1050mm from FFL
Cylinder Height: 958mm from FFL

Heritage Lock

Key Features of Heritage Lock are:

- DuoSecure - Increased Security
- Sturdy steel hook bolts
- Enhanced Security Pin
- Adjustable (+/- 2mm) locking box keeps
- Adjustable (+/- 2mm) latch keep
- Automatic locking on close
- PAS24:2022 compliant
- Higher euro cylinder location.
- 35mm lock backset

Operation:

On shutting door, hooks will automatically throw into locked position (activated by the magnet on the keep). Use Key or Thumbturn to throw deadbolt. Cylinder operation is required to unlock door.

11mm strong latching bolt keeps the door in position and ensures contact pressure

the hook bolt ensures security

The wide lock box allows for smooth operation of hook bolt

Tamper proof and dirt resistant magnetic release



IMPORTANT NOTE:
Each door fitted with Heritage lock will require 2no ACUL286 - Release Magnet

IMPORTANT NOTE:
Door height \geq 1985mm use Standard locks
Door height $<$ 1985 mm **no lock available**

		Lock	Keep	
			LH	RH
Size	Short	n/a	n/a	n/a
	Standard	ACUL415	1no ACUL416 2no ACUL418	1no ACUL417 2no ACUL419

Details

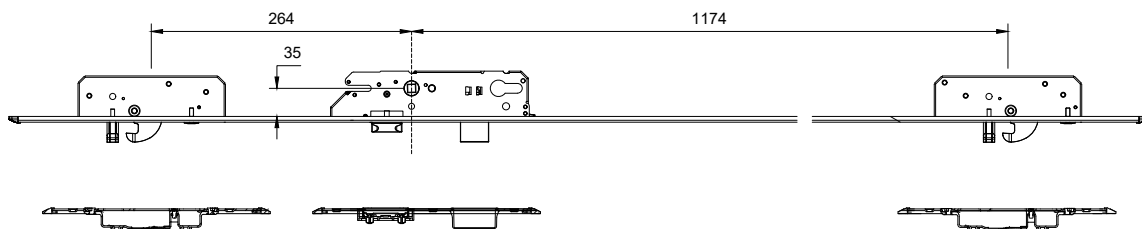

Spindle Height: 1500mm from FFL
Cylinder Height: 1408mm from FFL

Hinge Data

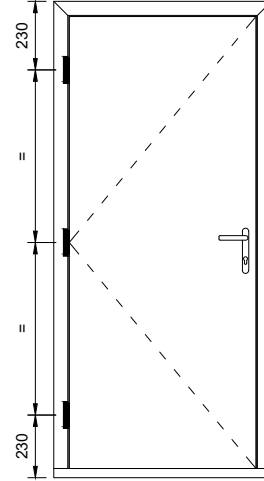

PAS24:2022	Materials	Corrosion Resistance UNI EN 1670	Load Capacity Per Hinge
Yes	Steel & Zamak	Minimum 1000 hours	35kg

Hinge Adjustment

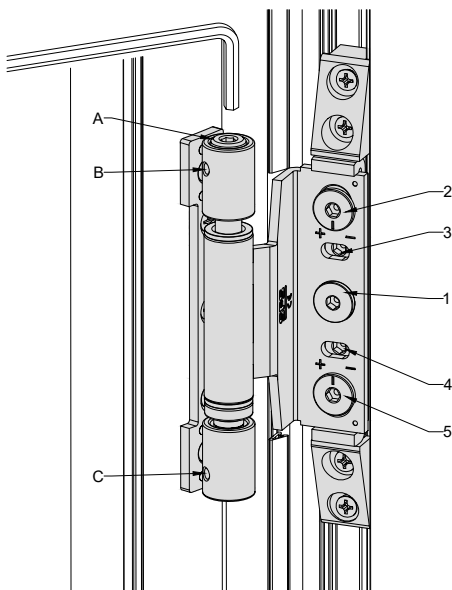

Horizontal Adjustment ($\pm 3\text{mm}$)

- Unscrew Screw 1 by three turns
- Tighten or loosen Grub Screws 3 and 4 with a 4mm Allen Key
- Tighten Screw 1

Gasket Pressure Adjustment ($\pm 2\text{mm}$)

- Unscrew Screw 1 by three turns
- Turn Screws 2 and 5 in direction of + or - to have more or less gasket pressure.
- Tighten Screw 1

Height Adjustment ($-2\text{mm}/+6\text{mm}$)

- Loosen Grub Screws B and C
- Turn Pin A
- Tighten Grub Screws B and C

INSTALL END CAPS AND COVERS AS SHOWN

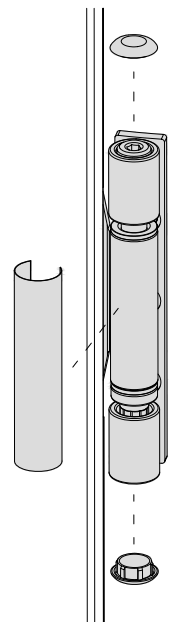

Cylinders

		Door Configuration	
		Open In	Open Out
Cylinder Operation	Key / Key	ACCY4835NKS3	ACCY3548NKS3
	Key / Thumbturn	ACCY4835NKTTTS3	ACCY3548NKTTTS3

OPEN IN

ACCY4835NKS3

← OUTSIDE

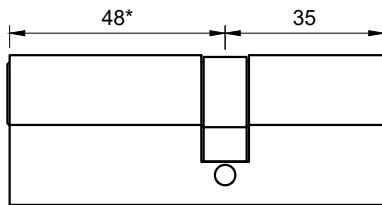

OPEN OUT

ACCY3548NKS3

← OUTSIDE

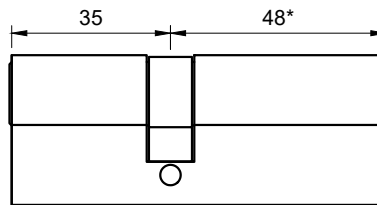

OPEN IN

ACCY4835NKTTTS3

← OUTSIDE

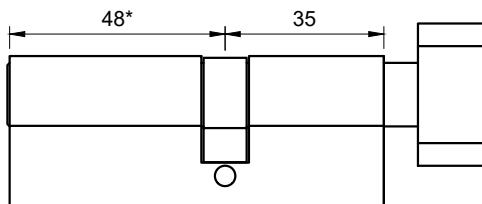

OPEN OUT

ACCY3548NKTTTS3

← OUTSIDE

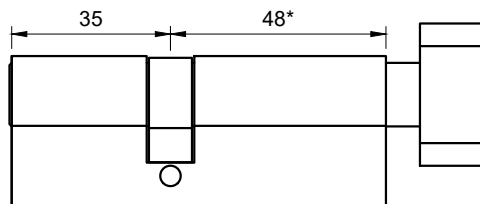

Security Rating	Spare Keys	Security Features	Extras*
BSI 3* Kitemarked Sold Secure Diamond Standard SBD Approved	3	Anti-Bump Anti-Pick Anti-Drill Anti-Tilt Anti-Snap	1hr Fire Rated Easy Turn Helix Thumbturn Standard Keyway for easy spares £4000 supplier guarantee

*Product size and brand are subject to change based on availability. All cylinders will be 3star rated, extras may vary depending on the supplier.

Architectural Handle Clearance

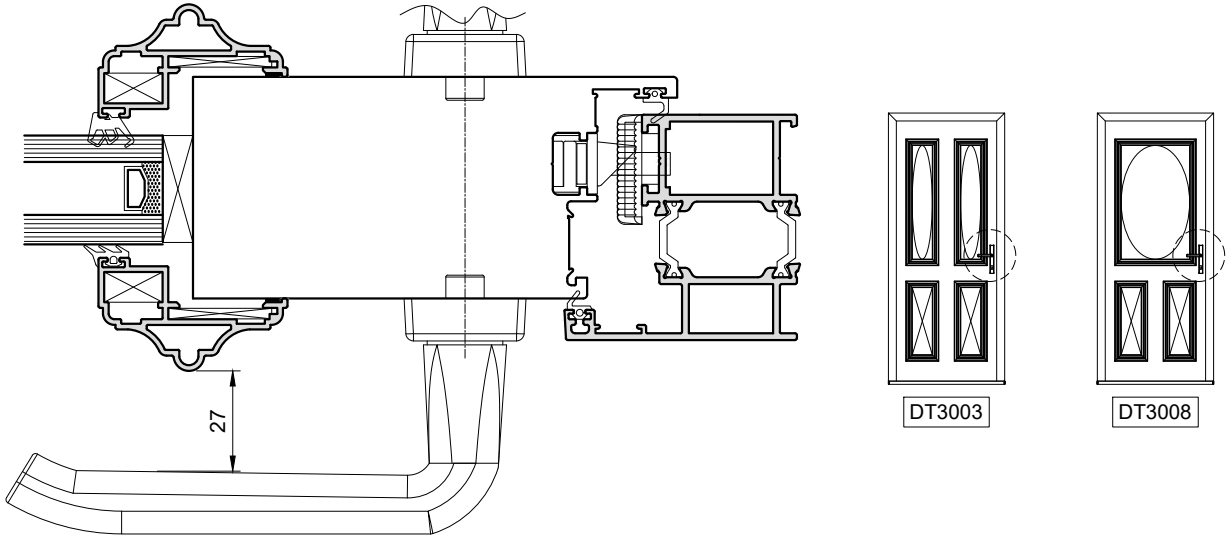

Architectural Handles on designs DT3003 & DT3008 will have minimal clearance between the handle and the glazing mouldings.

Architectural Handles are available on these designs upon request only.

Spyhole Position

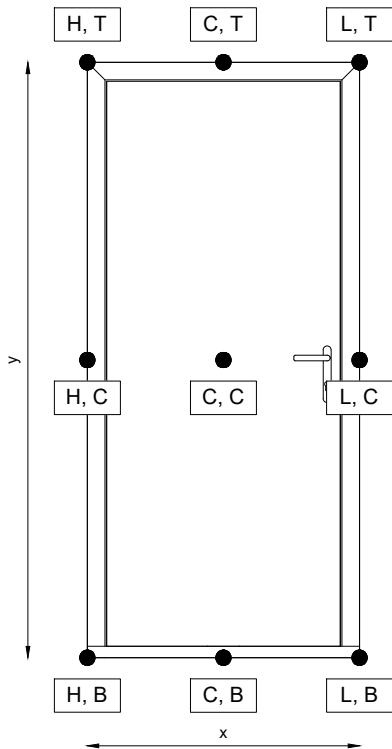

A **spyhole** or door viewer allows visual identification of callers without the need to open the door meeting the requirements for Approved Document Q.

Our Spyholes offer a wide 160° field of vision and are available in brass or chrome.

Design	Location	Origin	x	y
DM3003	C30	C, B	0	1500
DM3004	C30	C, C	0	540
DM3004	C40	C, C	0	360
DT3002	O25	L, B	-26	1450
DT3004	C30	C, C	0	500
DT3005	C40	C, T	0	-861
DT3006	C40	C, T	0	-923
DT3007	C40	C, T	0	-1001

IMPORTANT NOTE:

Dimensions are taken from outside of door frame. These dimensions do not account for cills or frame extensions.

Cylinder Heights

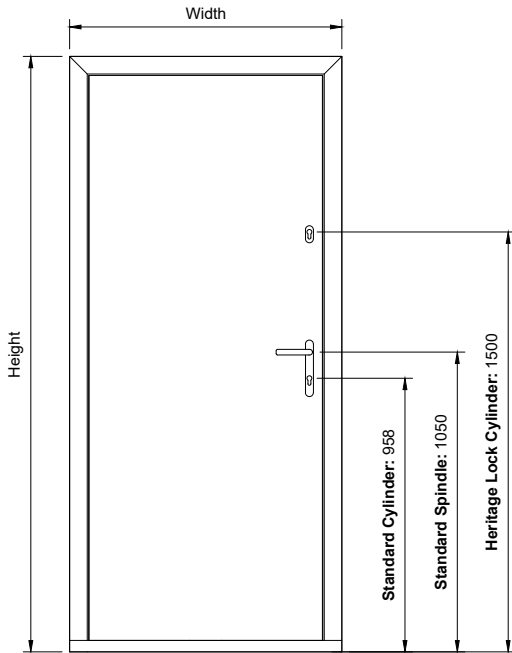

For Standard Lift Lever, Premium Lift Lever, Slam Lock, and Split Spindle Locks, the **spindle height** is set at 1050mm from the bottom of the door.

When using a Heritage Lock, the central locking point is positioned higher on the door, and a spindle is not required. Instead, the cylinder is placed at 1500mm from the bottom of the door.

For specific access control requirements, such as compliance with Approved Document M Category 2 or 3 dwellings, the spindle or cylinder height will be determined on a case-by-case basis*.

IMPORTANT NOTE:

Dimensions are taken from outside of door frame. These dimensions do not account for cills or frame extensions.

*Non-standard Door access control height, to be confirmed for each door. May incur additional charges.

Letterplate Positions

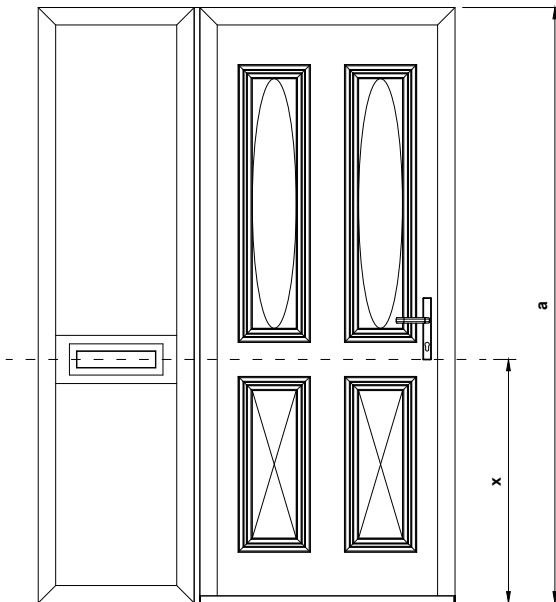

In order to calculate the height of the letterplate (x) on designs DT3003 & DT3008 please use the following formula:

$$(a / 2) - b$$

an example of this calculation is as follows:

Door height (a) = 2100
Threshold (b) used is 25mm Low Aluminium Threshold = 191.2

$$(2100 / 2) - 191.2$$

$$1050 - 191.2$$

$$x = 858.8$$

Threshold	'b'
25mm Low Aluminium Threshold	191.2
Standard Full Frame	180.0
15mm Low Aluminium Threshold (Part M)	190.1

IMPORTANT NOTE:

This calculation is for Designs DT3003 & DT3008 only.
For all other designs, please contact technical department.
Dimensions are taken from outside of door frame. These dimensions do not account for cills or frame extensions.

Furniture Options

Part Number	Description	Black	Graphite	Gold	Chrome	Matt Chrome	White	Stainless Steel	Nickel	Brass	Colour Match	Matt Black
ACCY3548NKS3	3* Cylinder Key / Key Open Out								Y			
ACCY4835NKS3	3* Cylinder Key / Key Open In								Y			
ACCY3548NKTTS3	3* Cylinder Key / Thumbturn Open Out								Y			
ACCY4835NKTTS3	3* Cylinder Key / Thumbturn Open In								Y			
ACPD6051	Nu Mail Letterplate	Y	Y	Y	Y		Y					
ACPD6052	Nu Victorian Urn Large Slim Face Fix w/ Spyhole	Y	Y	Y	Y		Y					
ACPD6151	Nu Victorian Urn Large Slim Face Fix	Y	Y	Y	Y		Y					
ACPD6200	Balmoral Inline Lever - Lever Handle	Y	Y	Y	Y		Y					
ACPD6201	Windsor Inline Lever - Lever Handle	Y	Y	Y	Y		Y					
ACPD6207	Architectural Inline Lever - Lever Handle		Y	Y	Y							
ACPD6208	Balmoral Inline Lever - Pad Handle	Y	Y	Y	Y		Y					
ACPD6209	Windsor Inline Lever - Pad Handle	Y	Y	Y	Y		Y					
ACPD6210	Architectural Inline Lever - Pad Handle		Y	Y	Y							
ACPD645	Spyhole				Y					Y		
ACPD741	Architectural Door Knocker	Y	Y	Y	Y							
ACPD742	Architectural Letterplate		Y	Y	Y							
ACPD746	Nu Victorian Urn Medium Face Fix	Y	Y	Y	Y		Y					
ACPD747	Nu Victorian Urn Medium Face Fix w/ Spyhole	Y	Y	Y	Y		Y					
ACPD748	Bull Ring Knocker	Y	Y	Y	Y							
ACPD759	Decorative Door Knob	Y	Y	Y	Y		Y					
ACPD775	Architectural Oval Cylinder Escutcheon	Y	Y	Y	Y		Y					
ACSM015	Oval Door Escutcheon							Y				Y
ACSM105	Rectangle Door Escutcheon							Y				Y
ACSM026	32mm Diameter x 400mm Round Pull Handle							Y				Y
ACSM087	Mitre Lever Handle on Oval Rose							Y				
ACSM088	Ergonomic Lever Handle on Oval Rose							Y				
ACSM089	T-Bar Lever Handle on Oval Rose							Y				
ACSM101	Round Bar Handle 1200mm							Y				Y
ACSM102	Round Bar Handle 1500mm							Y				Y
ACSM103	Round Bar Handle 1800mm							Y				Y
ACSM106	Rectangle Bar Handle 1200mm							Y				Y
ACSM107	Rectangle Bar Handle 1500mm							Y				Y
ACSM108	Rectangle Bar Handle 1800mm							Y				Y
ACSM104	LP200 Letterplate							Y				Y
ACUL250	3D Adjustable Hinge	Y				Y	Y				Y	
ACUN3141	Slim Fingerpull		Y	Y	Y		Y					

IMPORTANT NOTE:

Smart Systems Ltd only provides hardware warranty for products supplied by us. Any hardware not supplied by us is not covered under this warranty. We cannot be held responsible for the installation, maintenance, or repairs of such products.

BLANK PAGE

Site Survey & Installation

Site Survey

THIS IS A GUIDE ONLY.

Survey should always be conducted by competent person.
We do not accept liability for inaccurate surveys.

Measure both Internal and External Dimensions

Width measure at 3 points; top, middle and bottom. Take the smallest measurement and deduct 10mm.

Height measure at 3 points; left, middle and right. Take the smallest measurement and deduct 10mm.

Diagonal measure at 2 points; bottom left corner to top right corner and bottom right corner to top left corner. These dimensions should be within 5mm of each other.

Internal dimensions should be taken from plasterline to plasterline.

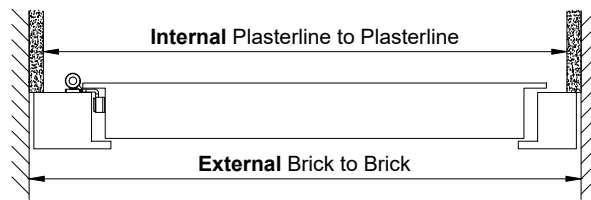

External dimensions should be taken from brick to brick and to below any existing cills (if cill is being replaced).

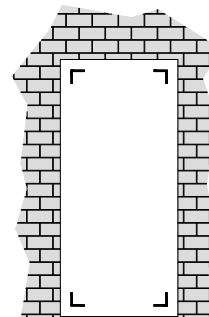
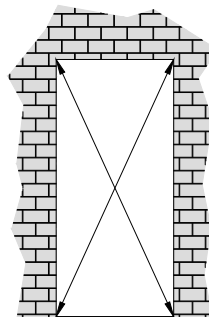
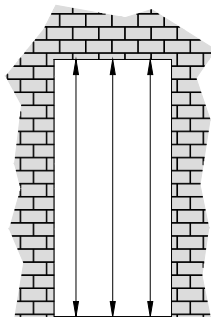
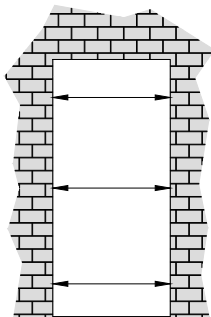

Extra Considerations

Considerations when conducting site survey:

- Is the opening level?
- Is the opening square?
- Are the walls plumb?
- Is a cill required?
- Is the reveal depth adequate?
- Are any specific fixings or fasteners needed?
- Is there sufficient clearance for the hinges to operate?
- Is an add on required?
- Will the door operate without any obstructions?
- Is the clear opening suitable for the customer's needs?
- Are trims needed to complete the installation?
- Does this door need to be DDA compliant?
- Does the door require a cill?
- Is the colour suitable for this location?

Installation

To ensure satisfactory operation doors should only be fitted by experienced installers using appropriate tools and equipment. Failure to follow the steps in this guide may result in unsatisfactory operation.

IMPORTANT:

DO NOT OPEN THE DOOR UNTIL IT IS HELD SQUARE IN THE APERTURE USING AIR BAGS. DOORS ARE A SOLID 'SLAB' DESIGN THAT CANNOT BE 'TOE & HEELED'. THE CORRECT INSTALLATION OF THE OUTER FRAME IS CRITICAL TO THE OPERATION OF THE DOOR

1. Offer the door into the aperture.
2. Place an air bag on the hinge side at the bottom of the outer frame.
3. Place an air bag on the lock side at the top of the outer frame.
4. 'Square up' the hinge side by deflating/inflating the air bag and using a spirit level/laser level.
5. Using the air bag on the lock side adjust the door until there is even sash coverage.
6. Place air bags into top hinge side and bottom lock side. Inflate air bags to hold the door in securely in place.
7. Open the sash and remove the lock keep.
8. Check that the hinge jamb is level. Fix the hinge jamb through the aluminium (DO NOT fix through the polyamide). **Please Note:** ensure the first fixing is located within 50mm of the top hinge. All fixings should be in accordance with British Standard BS8213-4:2016.
9. Before fixing the lock jamb confirm the door opens and closes satisfactorily. If not, use the air bags to adjust the alignment of the lock jamb with the sash. Once the door operates correctly fix the lock jamb through the aluminium (DO NOT fix through the polyamide).
10. Re-fit the lock keep onto lock jamb. Test to confirm door latches & locks satisfactorily. If the door operates correctly then final fix the lock keep.

EXAMPLE FIXING LOCATIONS

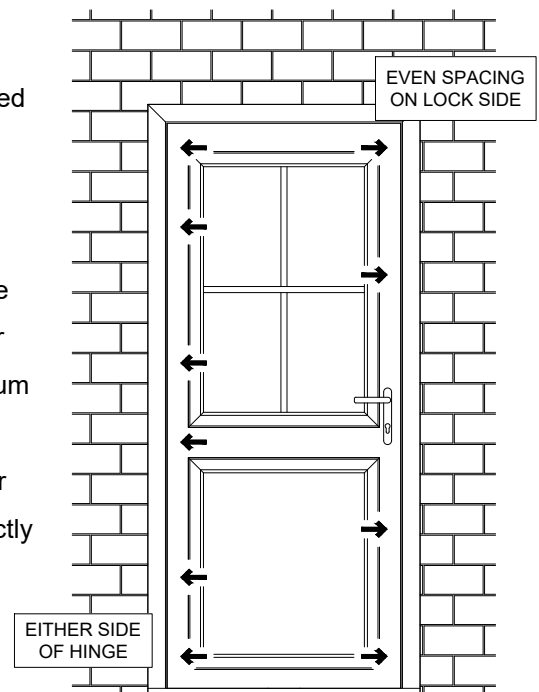

Installation Components

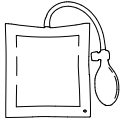

Air Bag

ACPD760

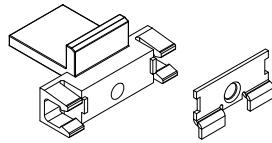

Glass Retainer & Metal Faceplate

ACPD322 & ACPD328



E Gasket

ACVG31

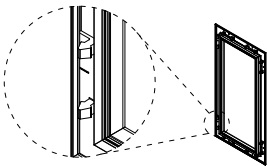

Internal Moulding

Size & Design Dependant

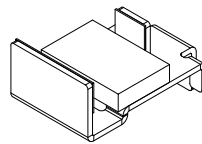

Glass Clips

ACPD338

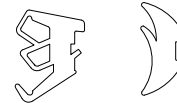

Wedge Gasket

ACVG340N or ACPVG34

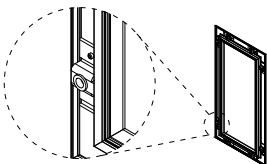

External Moulding

Size & Design Dependant

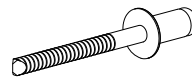

4.8mm x 10mm SS CSK Pop rivet

ACUN3548

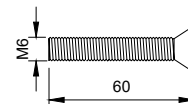

M6 Machine Screw

ACET235

De-Glaze Mouldings

Recommended:

- 2 people

Method:

1. Carefully run a sharp blade around the edges of both internal and external mouldings, loosening the silicone.
2. Remove wedge gasket from internal moulding. Using a glazing spade, apply levering action to push the internal moulding away from the door skin. Repeat this process at multiple locations around the perimeter. As a result, the internal moulding should detach. Set this aside.
3. Remove the machine screws from the glass retainers, ensuring the external moulding and glass are supported to prevent dropping. For PAS24:2022, drill out pop rivets and remove glass clips by pushing them toward the centre of the glass before removal.
4. Set aside the external moulding and glass unit.
5. Remove any remaining silicone from the door skins and mouldings, taking extra care to avoid scratching or damaging these components.

Re-Glaze Mouldings

Recommended:

- 2 people
- door to be horizontal on trestles

External Gasket	Internal Gasket
ACVG31	ACVG340N or ACGV34

Method:

1. Run an appropriate silicone bead along the perimeter channel of the external moulding to ensure a watertight seal.
2. Fit the external moulding to the door slab opening. For PAS24:2022:
 - 2.1. Install glass clips on one side of glazing aperture and on the opposite side of glass unit.
 - 2.2. Use a glass sucker to angle the glass into the clips installed on the slab, lower into aperture, then align holes in glass clips in holes in internal skin.
 - 2.3. Push the clips to engage behind the aluminium skin, repeat and fix into place using 4.8mm x 10mm SS CSK Pop Rivet.
3. Use a glazing spade to position the glass centrally. Slide the glass retainers around the perimeter of the glass, through the cut outs in the foam core and aluminium skin. Fasten the retainers to the rivuts in the external moulding using M6 Machine screws, ensuring that the metal lip of each retainer face plate, lips over the internal door skin. **Be cautious not to overtighten the screws - please use lowest torque setting.** Repeat this step in at least 2 opposite corners to hold the glass and external moulding securely in position.
4. Now that the glass is secure, proceed to install the remaining glass retainers. Make any necessary adjustments and pack the glass as required.
5. Apply silicone to the perimeter channel of the internal moulding.
6. Position the internal moulding over the glass retainers and push it firmly until it snaps in place.
 - 6.1. If the moulding is difficult to install, it may be down to glass retainers being overtightened.
 - 6.2. To resolve this, loosen the M6 screws slightly and insert cut down 2mm-thick glazing packers behind the glass retainers as shown below. Re-tighten M6 machine screws.
 - 6.3. This will shift the glass retainers towards the internal skin, making it easier to install the internal moulding.
7. Wipe away any excess silicone on door skins.
8. Fit wedge gasket to internal moulding ensuring a straight, ripple-free finish.

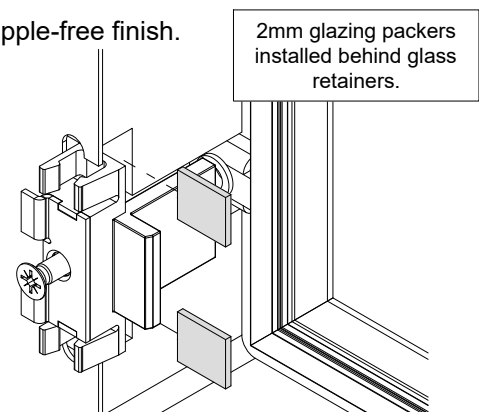
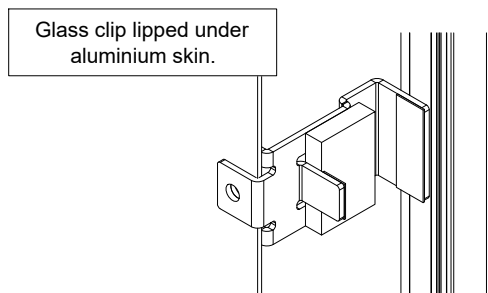

BLANK PAGE

Sectional Details

Add on

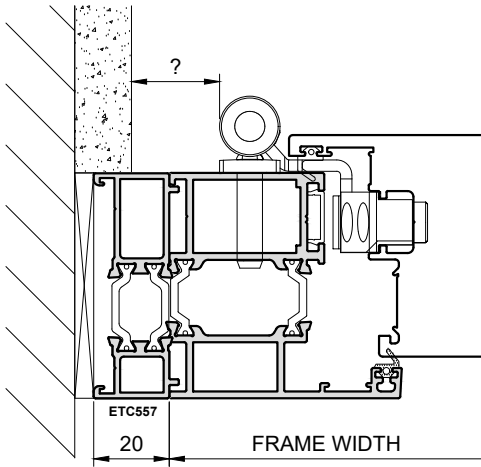

ETC557 Add on is available to add 20mm onto outerframe profile.

Ensure there is enough clearance on the hinge side to ensure smooth operation without any binding or resistance.

Couplers

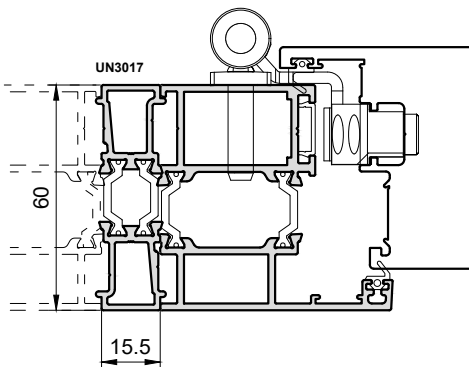

Coupling Profile, UN3017 allows profile coupling of door to sidelight and sidelight to sidelight.

It is also compatible with coupling Signature Range Doors to Alitherm 600 Windows.

Wind loadings should be calculated on all screen work.

Stepped Coupling Profile, UN3018 allows profile coupling of Signature door to 70mm sidelight.

Example: Coupling Signature Range Doors to Alitherm 400 ETD410 Fixed light.

Wind loadings should be calculated on all screen work.

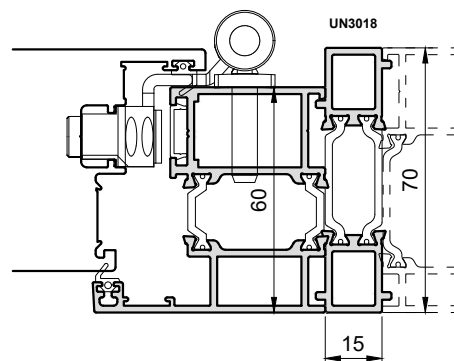

Cills

Cills are available as:

- 150mm - ETC457
- 190mm - ETC458

Cills are compatible with both full frame and low threshold

When Cills are used, 25mm should be taken off the height of the door.

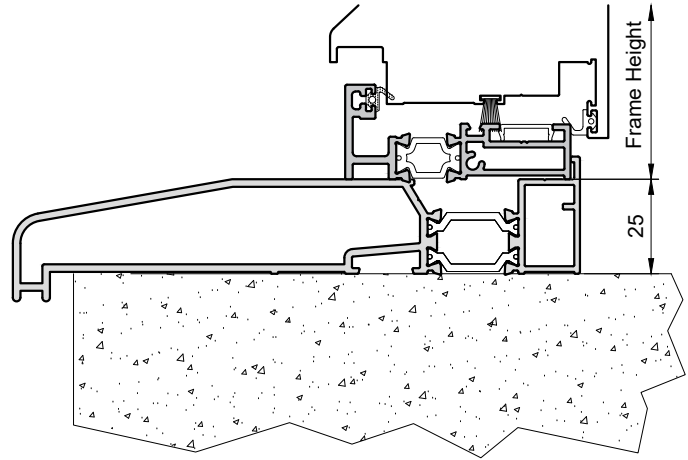

Trims

Flat Trim
25mm x 4mm
50mm x 3mm
70mm x 5mm
100mm x 5mm

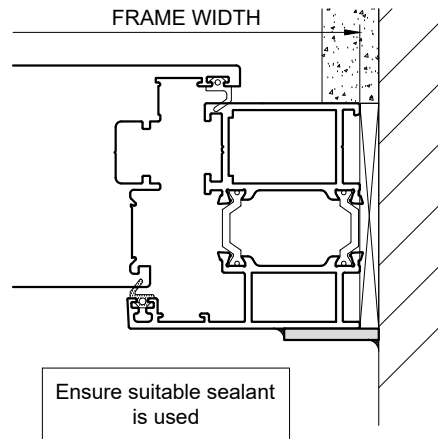

25mm Low Aluminium Threshold

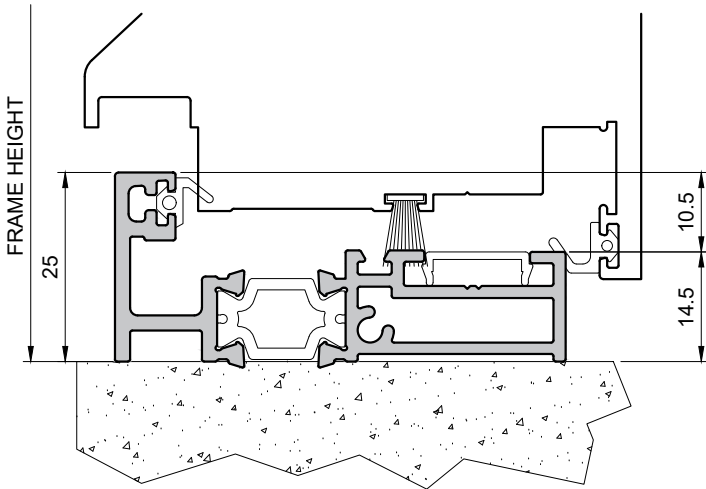

25mm Low Aluminium Threshold offers a sleek alternative to traditional full frame threshold.

It is double rebated and has 3 weather seals for great weather and thermal performance.

Available for both open in and open out doors.

Low Threshold is available in Satin Anodised only.

Please see 'maintaining your door' section for cleaning advice.

Standard Full Frame (FPR)

Standard Full Frame Threshold offers the classic composite style full frame threshold. It is double rebated and 2 weather seals for great weather and thermal performance.

Available for both open in and open out doors.

Full frame threshold is available in all colours to match your door surround.

Please see 'maintaining your door' section for cleaning advice.

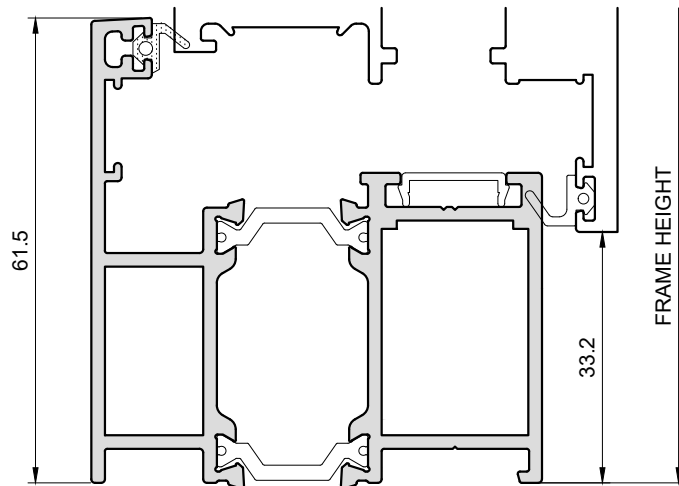

15mm Low Aluminium Threshold (Part M)

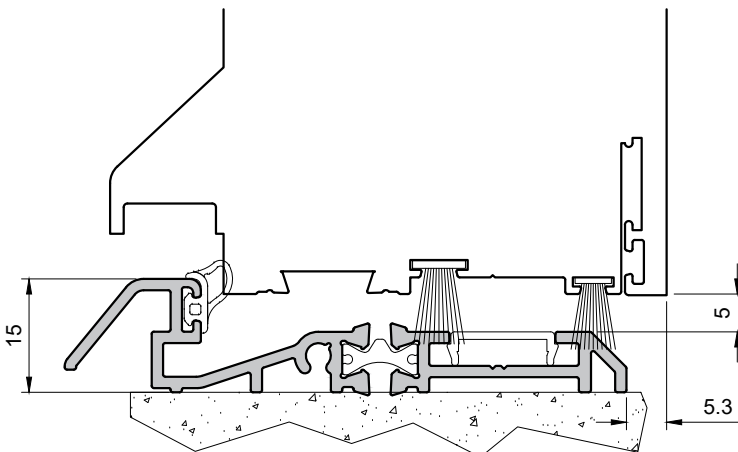

15mm Low Aluminium Threshold (Part M) offers safe access for everyone.

Designed to conform with government regulations, the Part M Compliant Threshold is the perfect choice for new build projects.

Available for open in only.

15mm Low Aluminium Threshold is available in Satin Anodised only.

Please see 'maintaining your door' section for cleaning advice.

Open In - Sectional Details

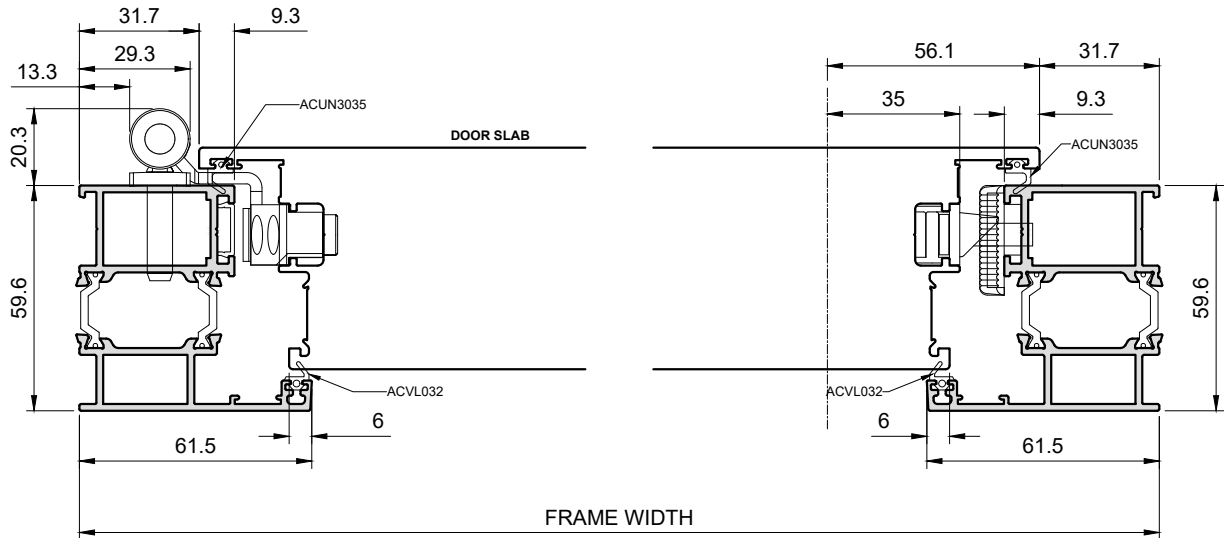

Open Out - Sectional Details

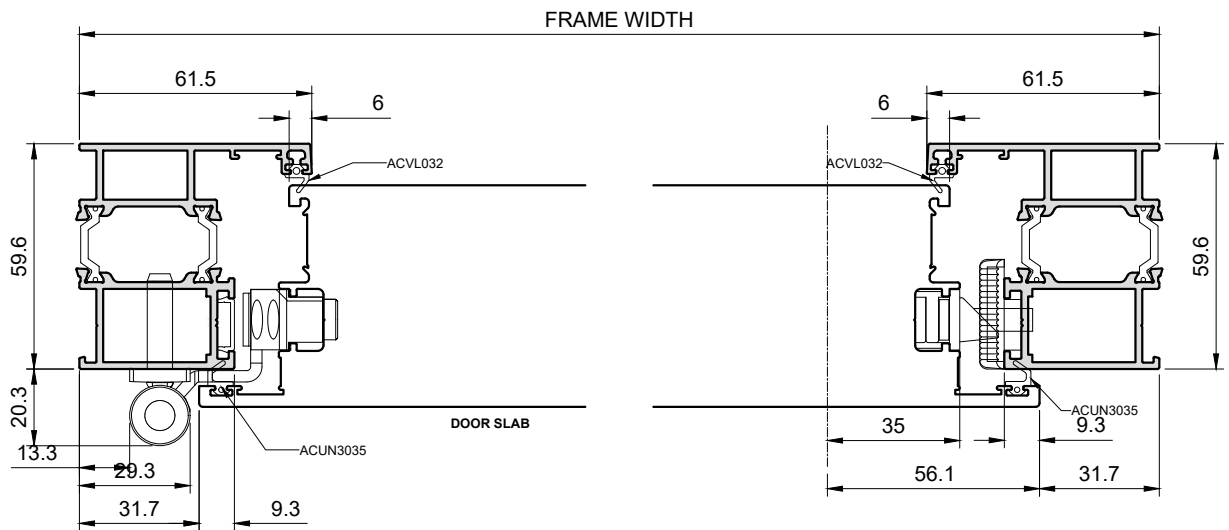

Open In - Hinge Jamb

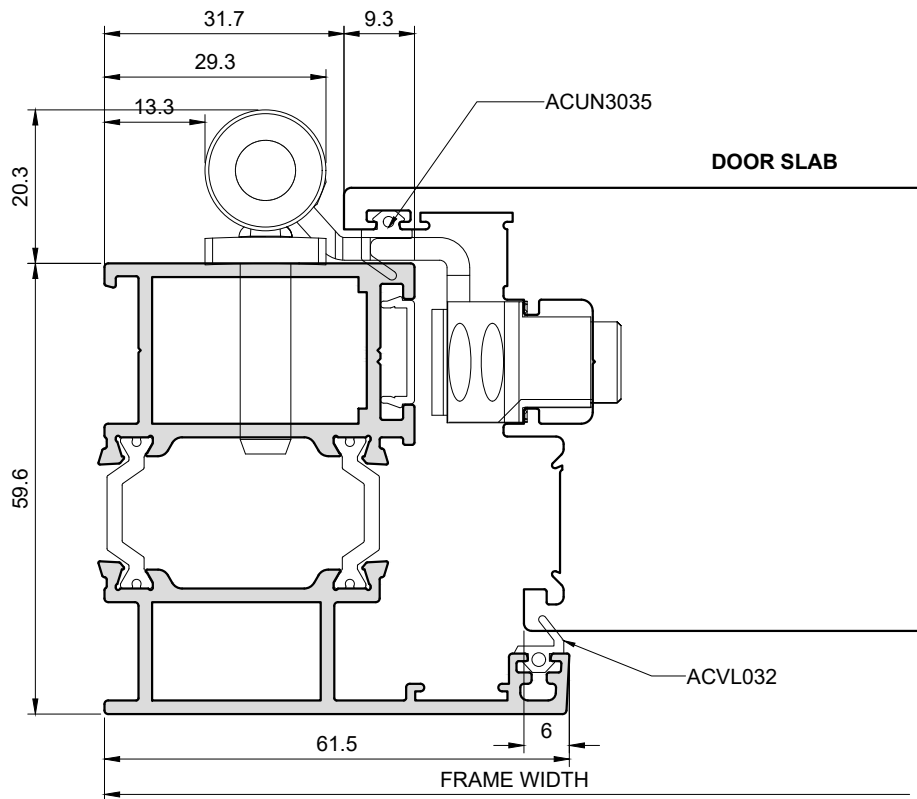

Open Out - Hinge Jamb

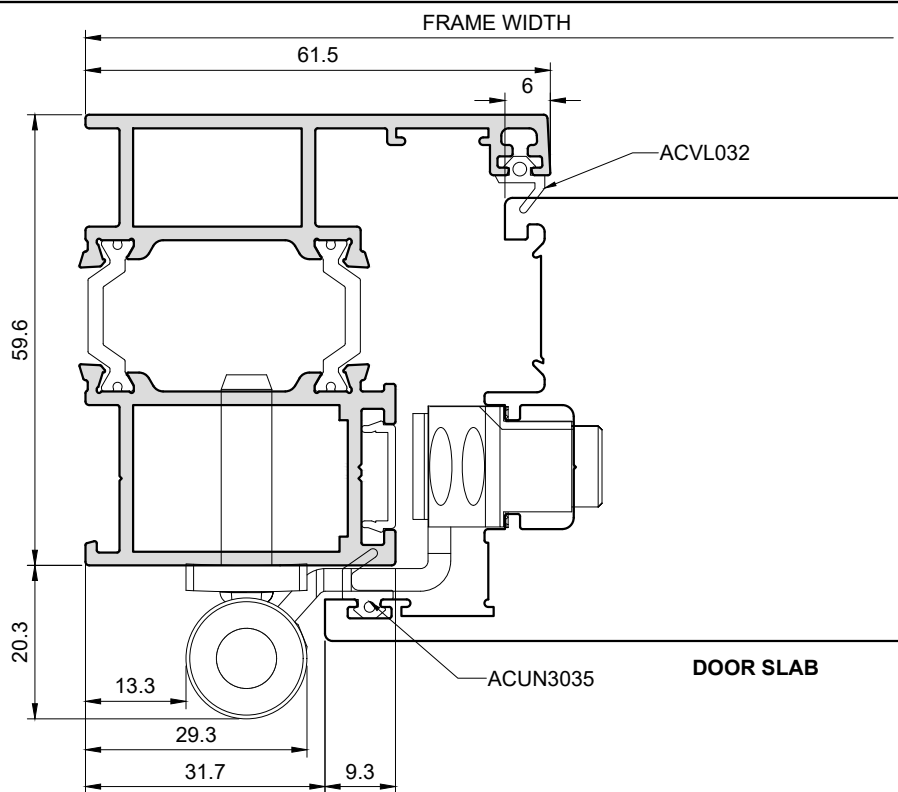

Open In - Lock Jamb

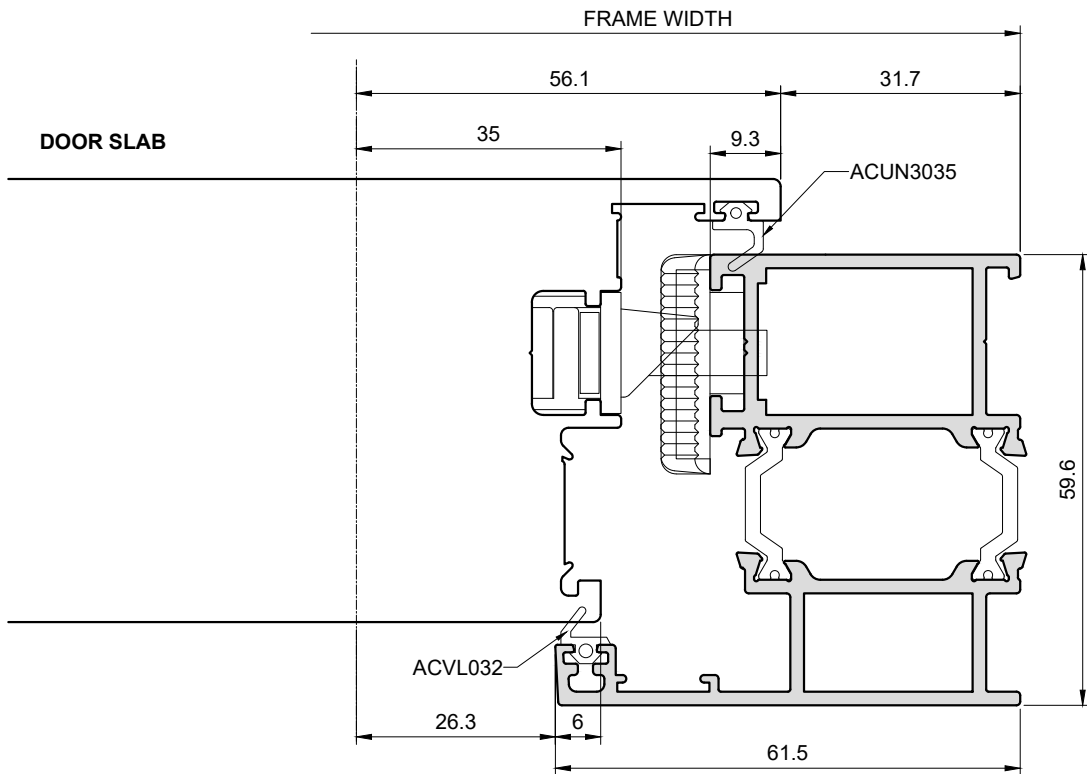

Open Out - Lock Jamb

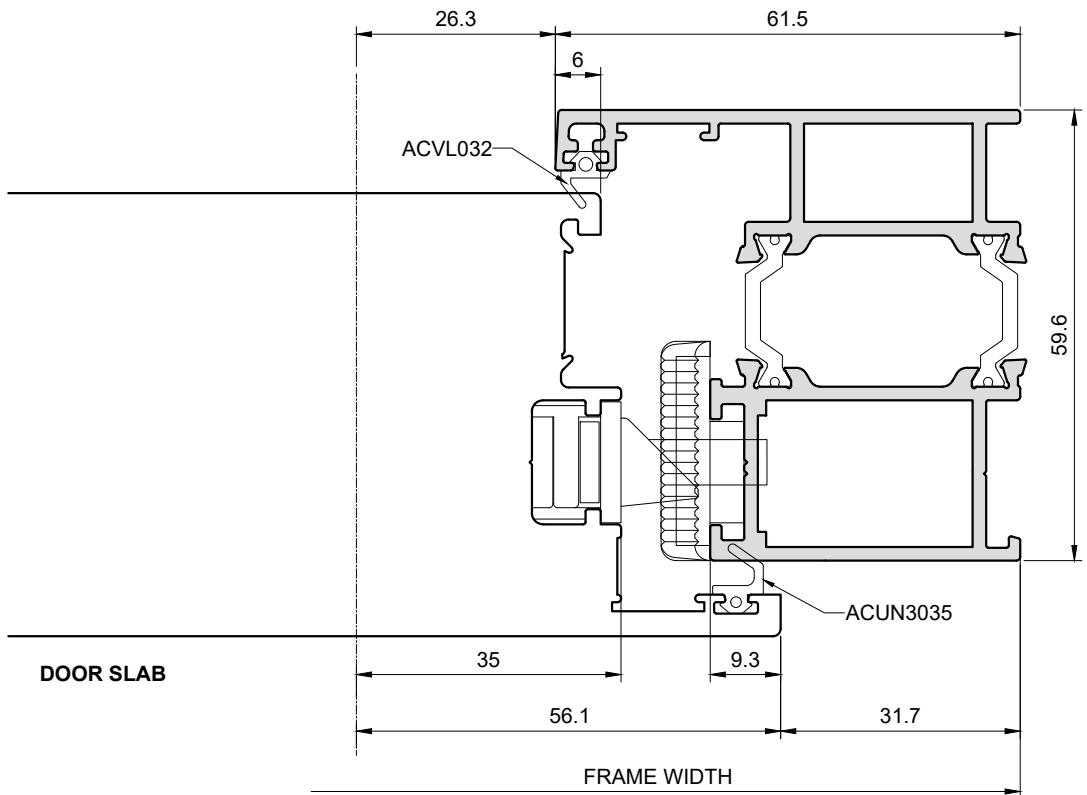

Open In - Hinge Jamb with Add on

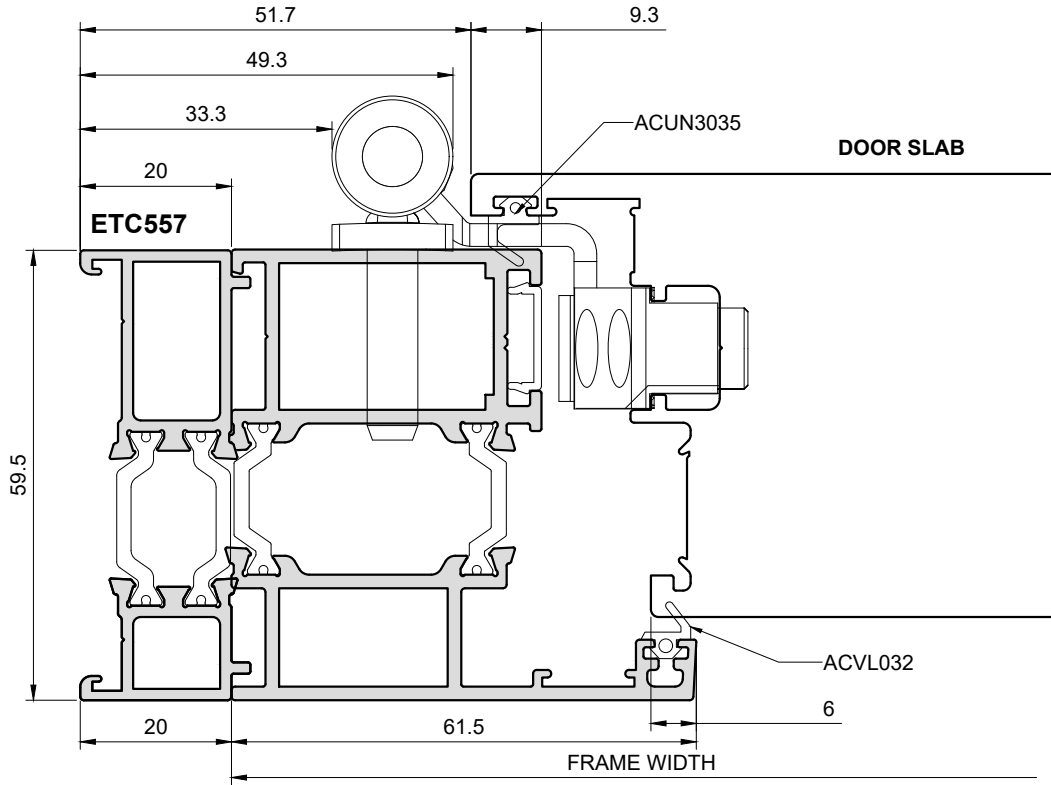

Open Out - Hinge Jamb with Add on

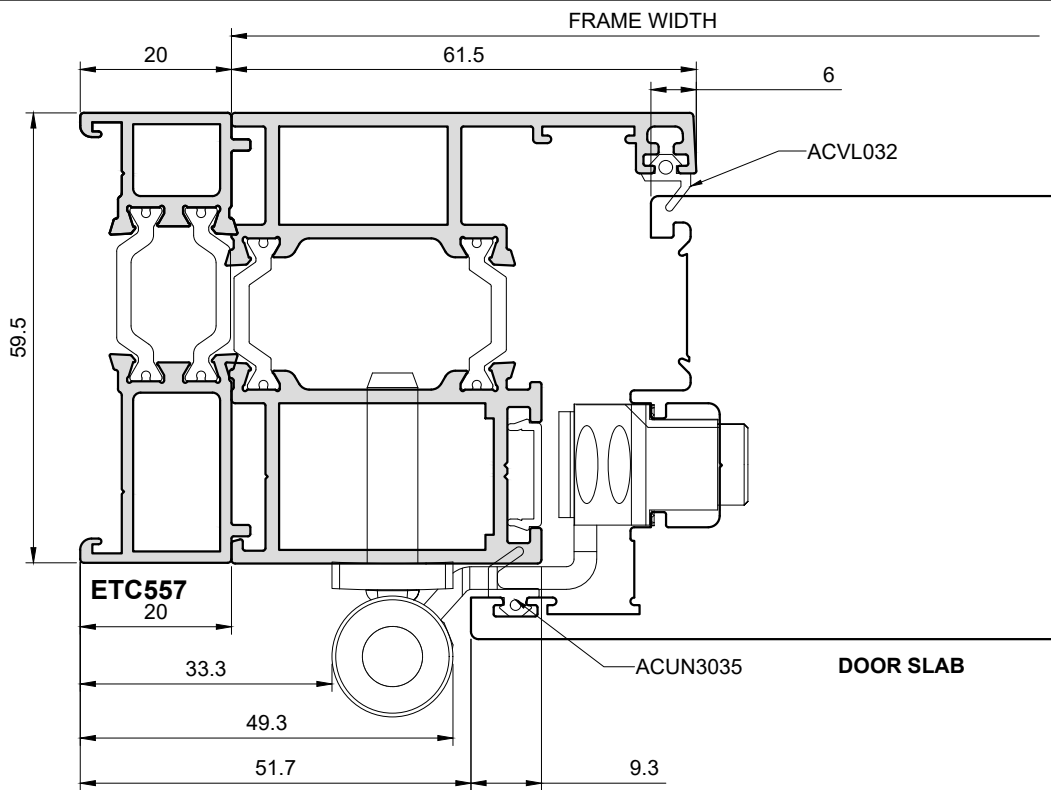

Open In - Lock Jamb with Add on

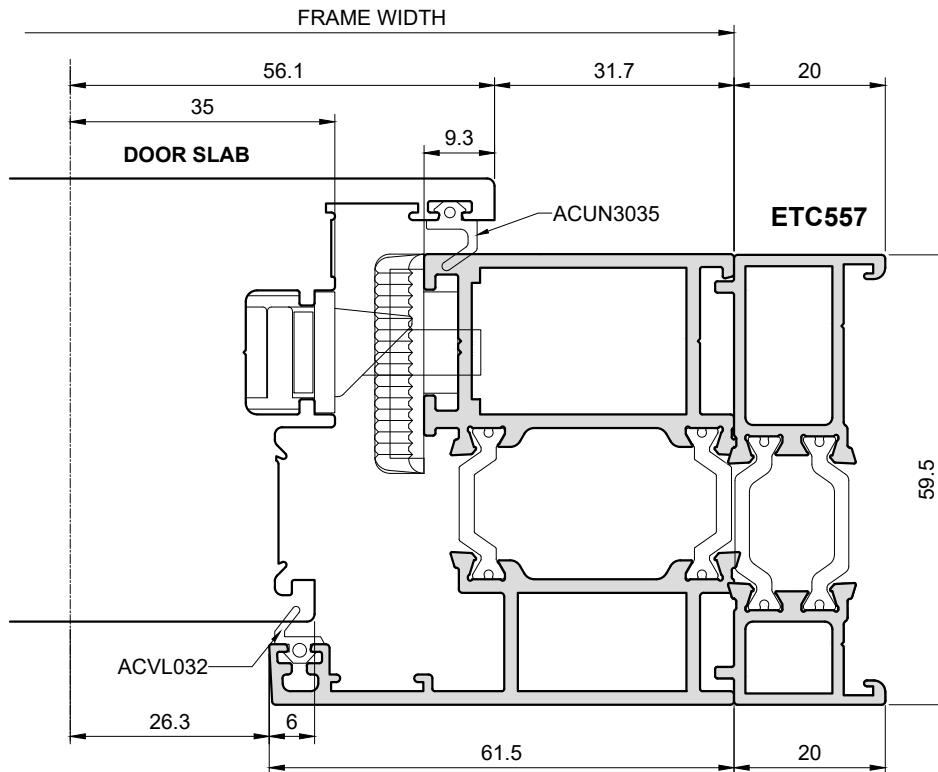

Open Out - Lock Jamb with Add on

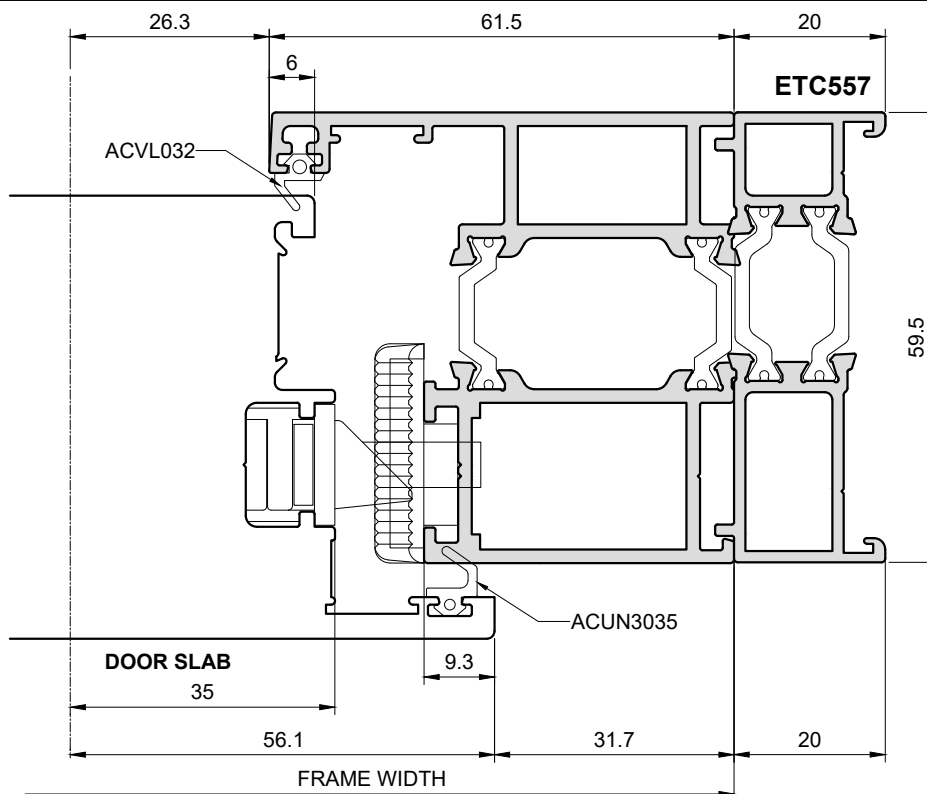

Open In - Hinge Jamb with Coupler

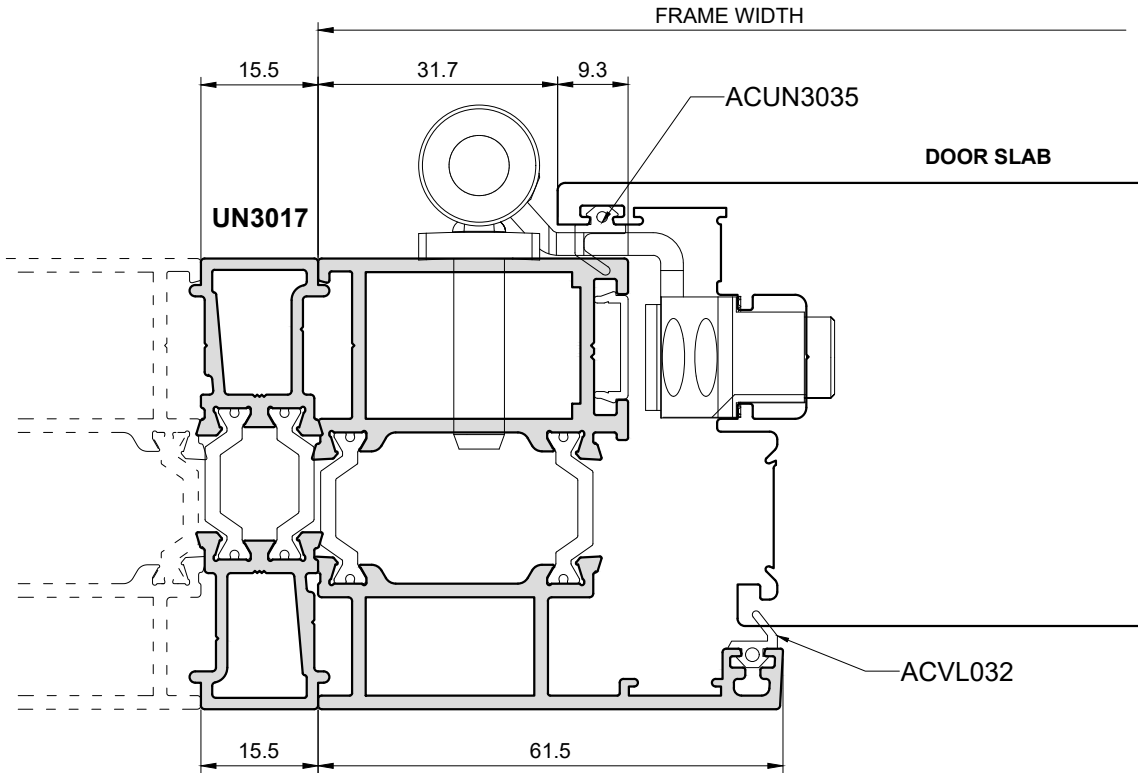

Open Out - Hinge Jamb with Coupler

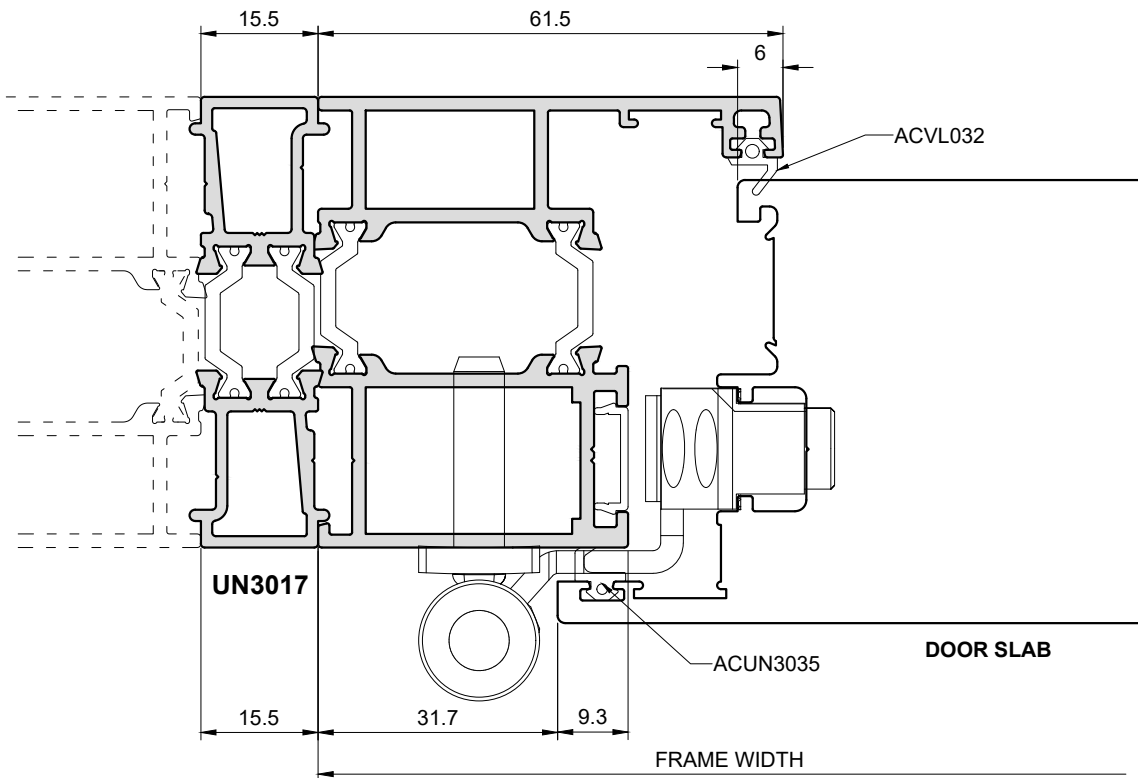

Open In - Lock Jamb with Coupler

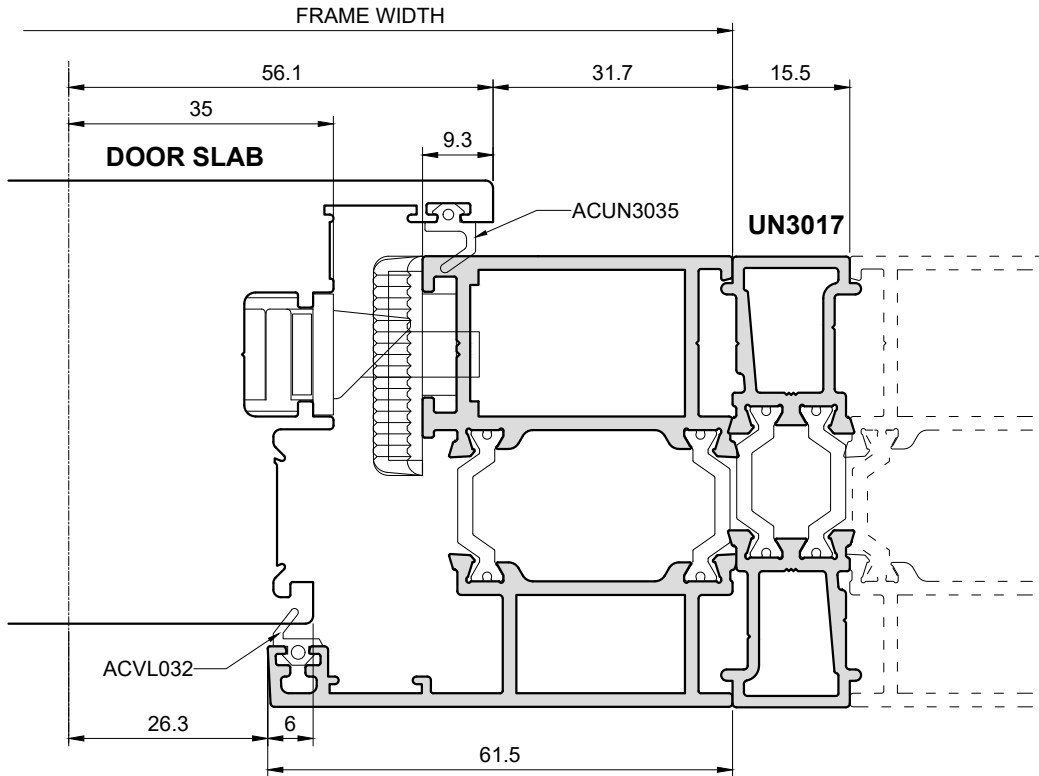

Open Out - Lock Jamb with Coupler

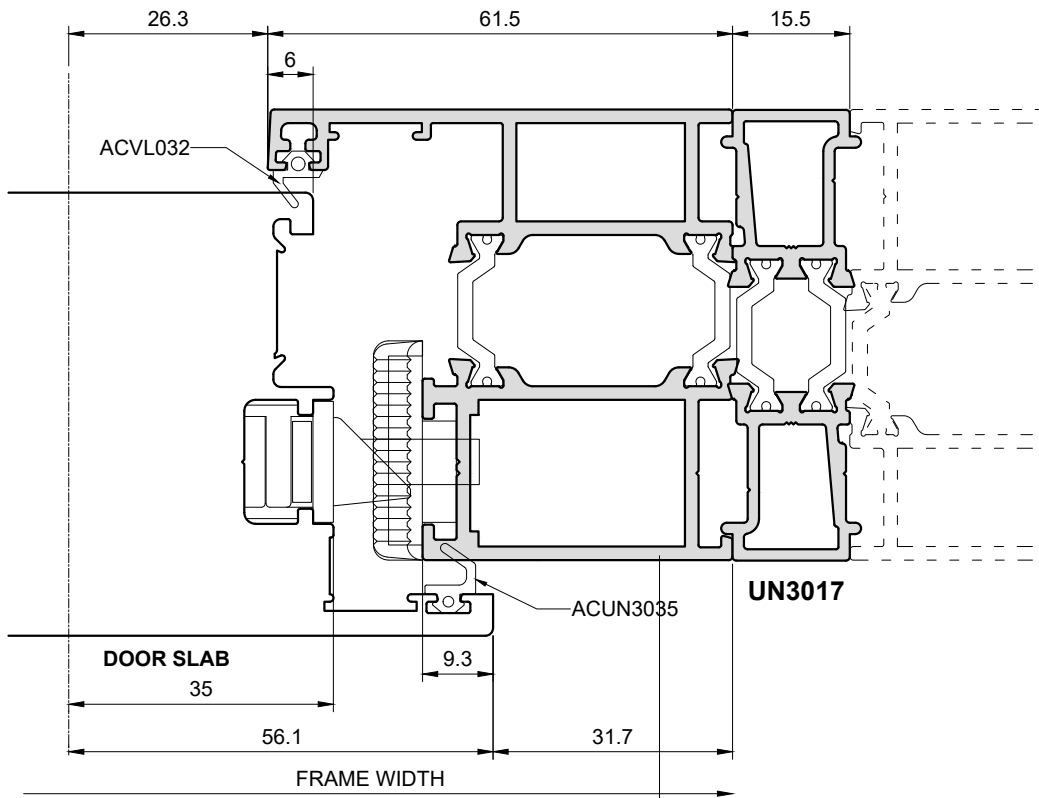

Open In - 25mm Low Aluminium Threshold

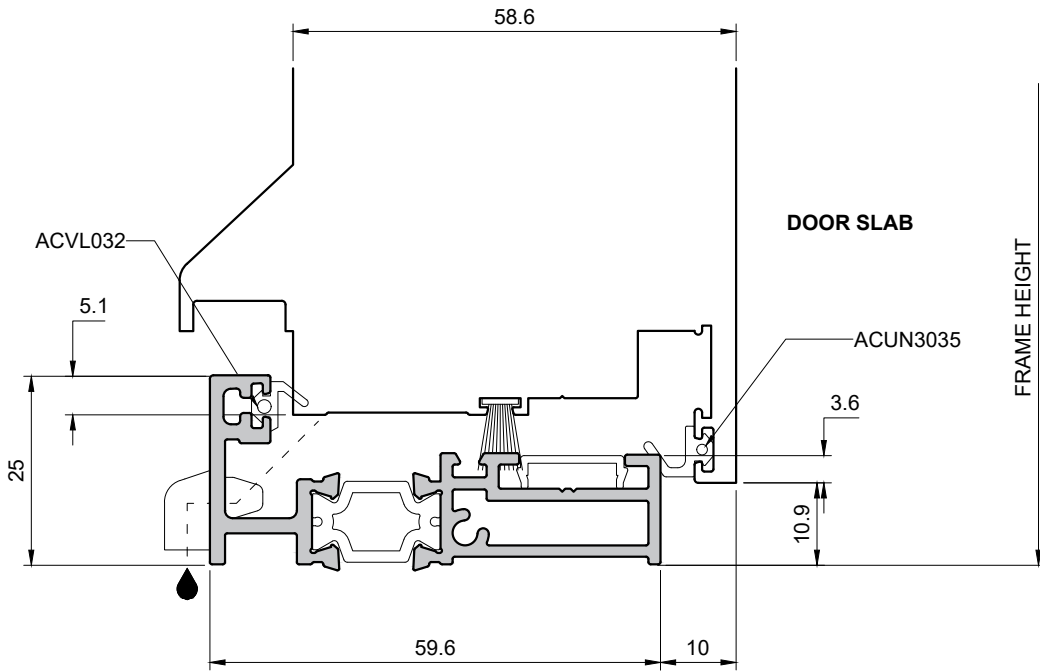

Open Out - 25mm Low Aluminium Threshold

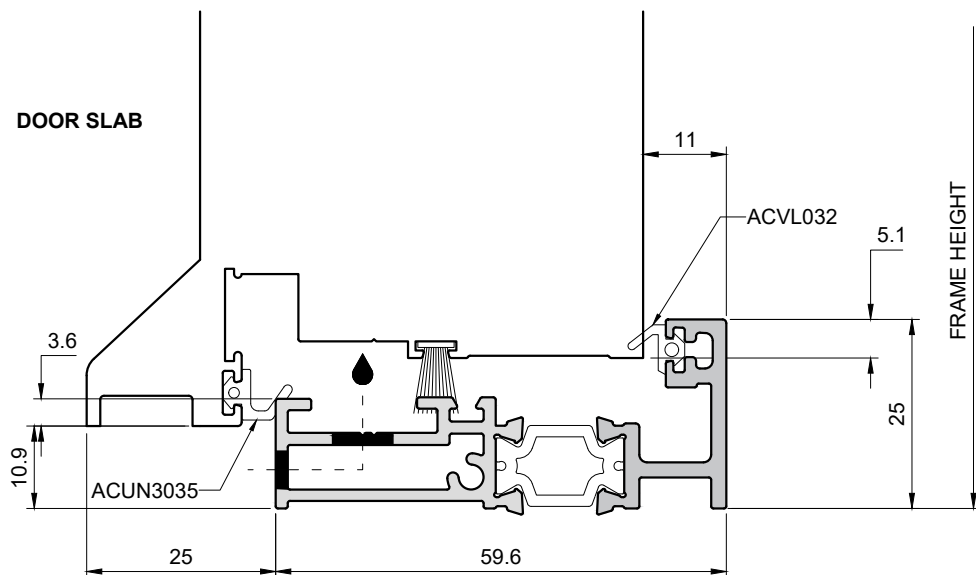

Open In - Standard Full Frame

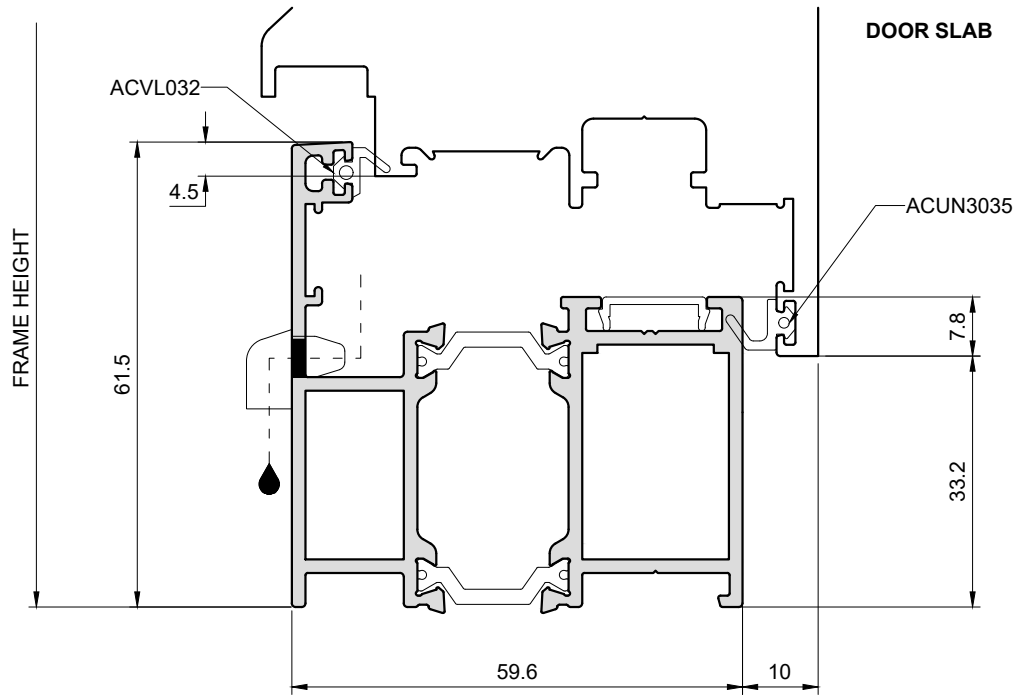

Open Out - Standard Full Frame

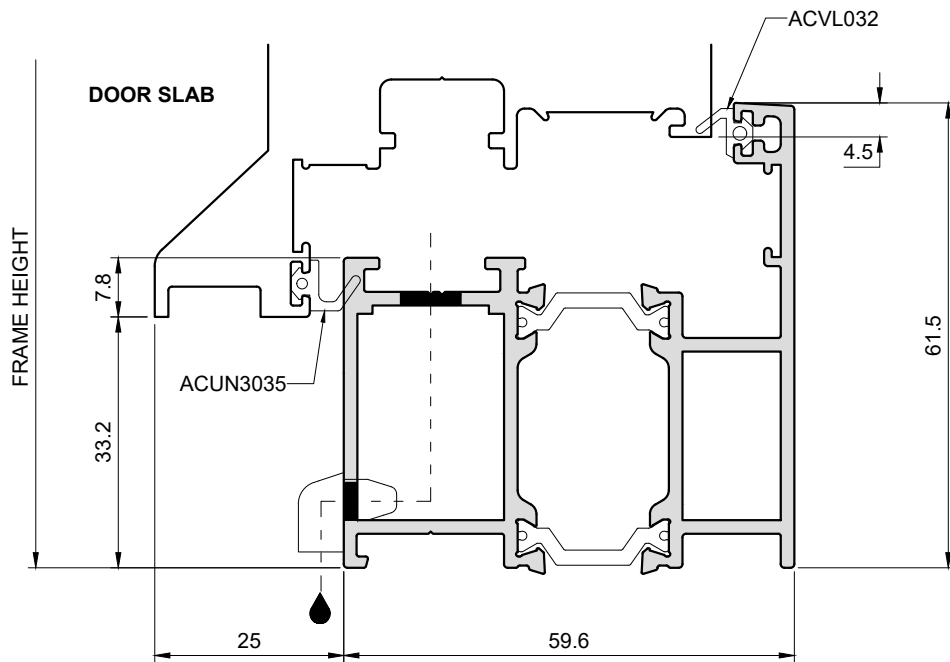

Open In - 15mm Low Aluminium Threshold (Part M)

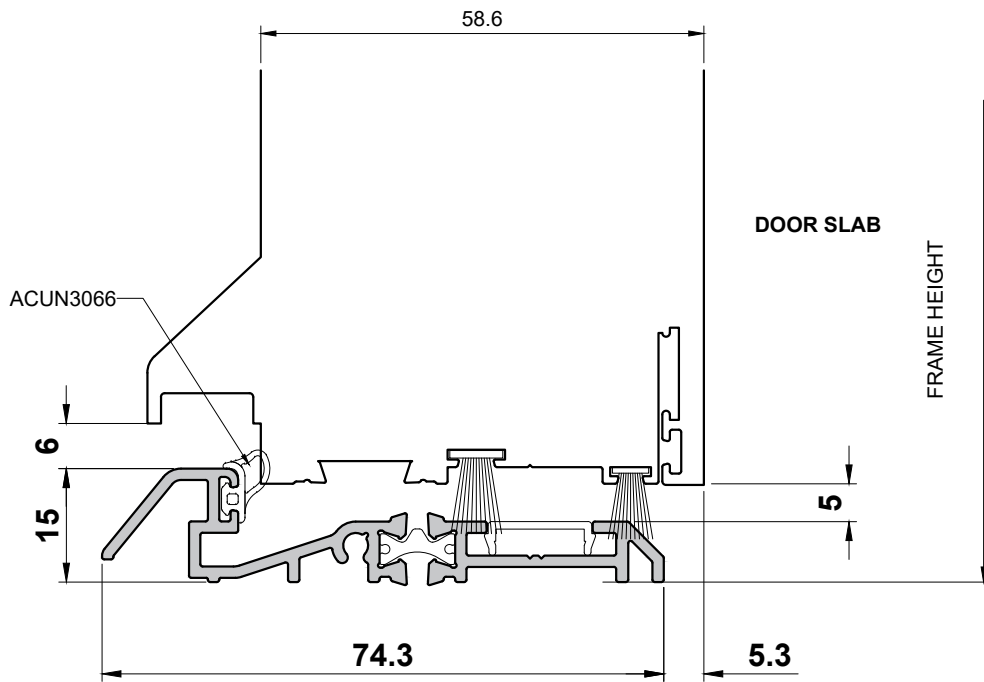

Open In - 25mm Low Aluminium Threshold with Cill

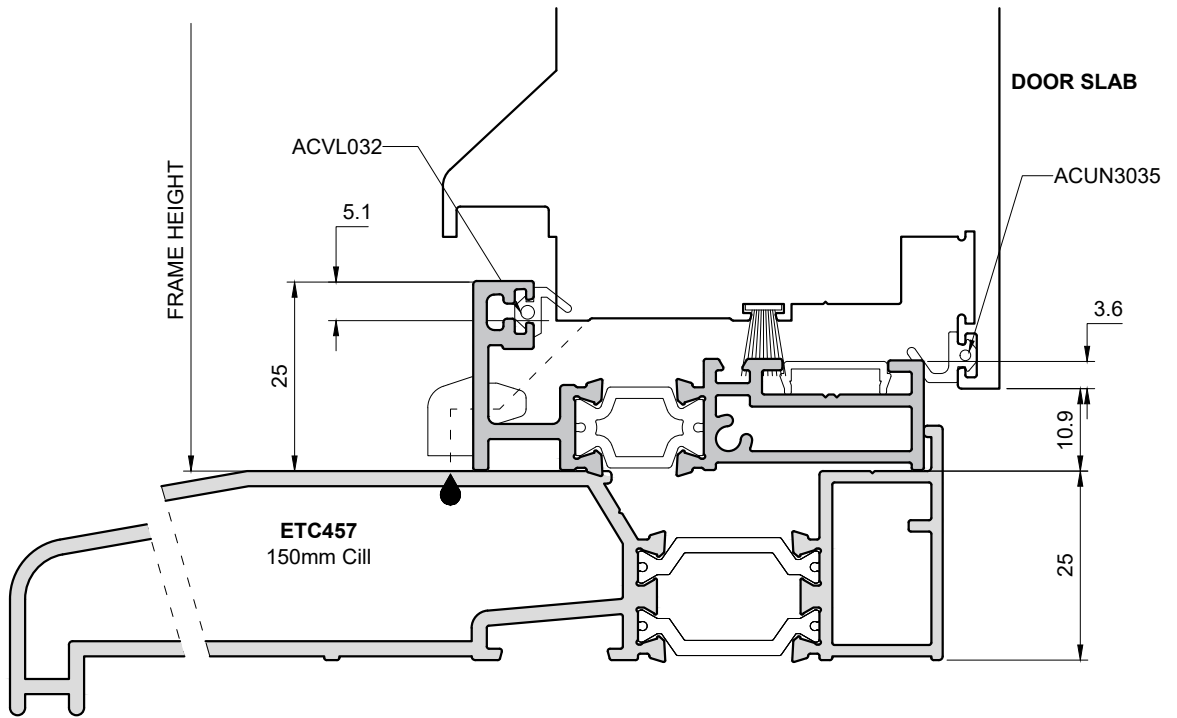

Open Out - 25mm Low Aluminium Threshold with Cill

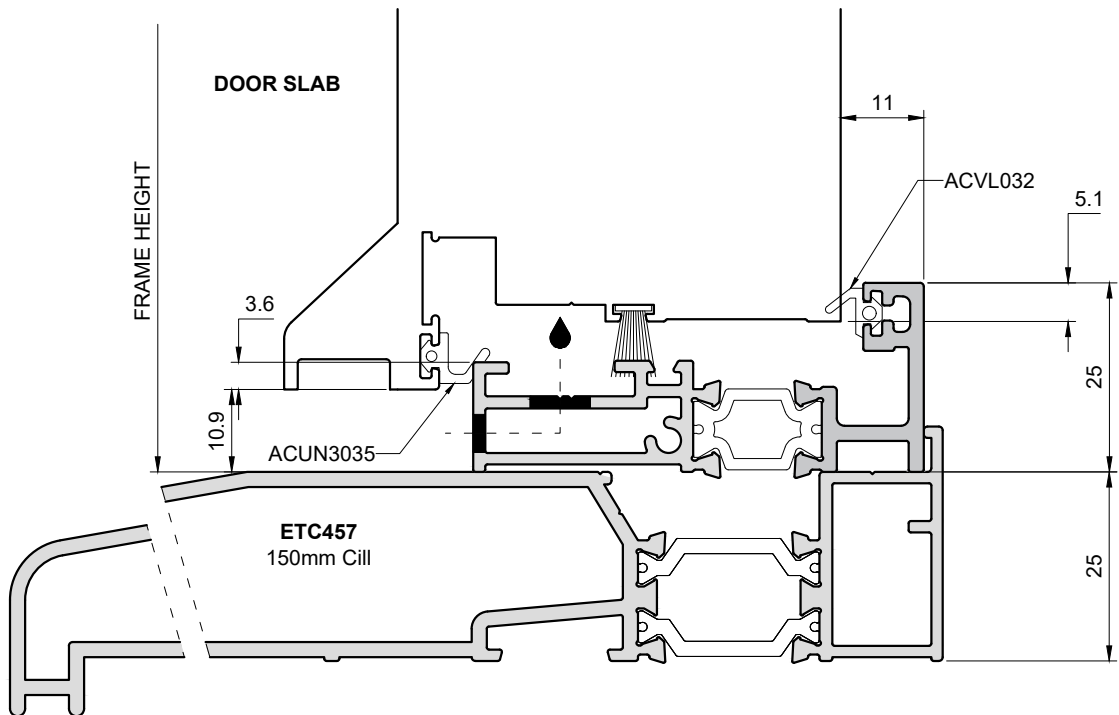

Open In - Standard Full Frame with Cill

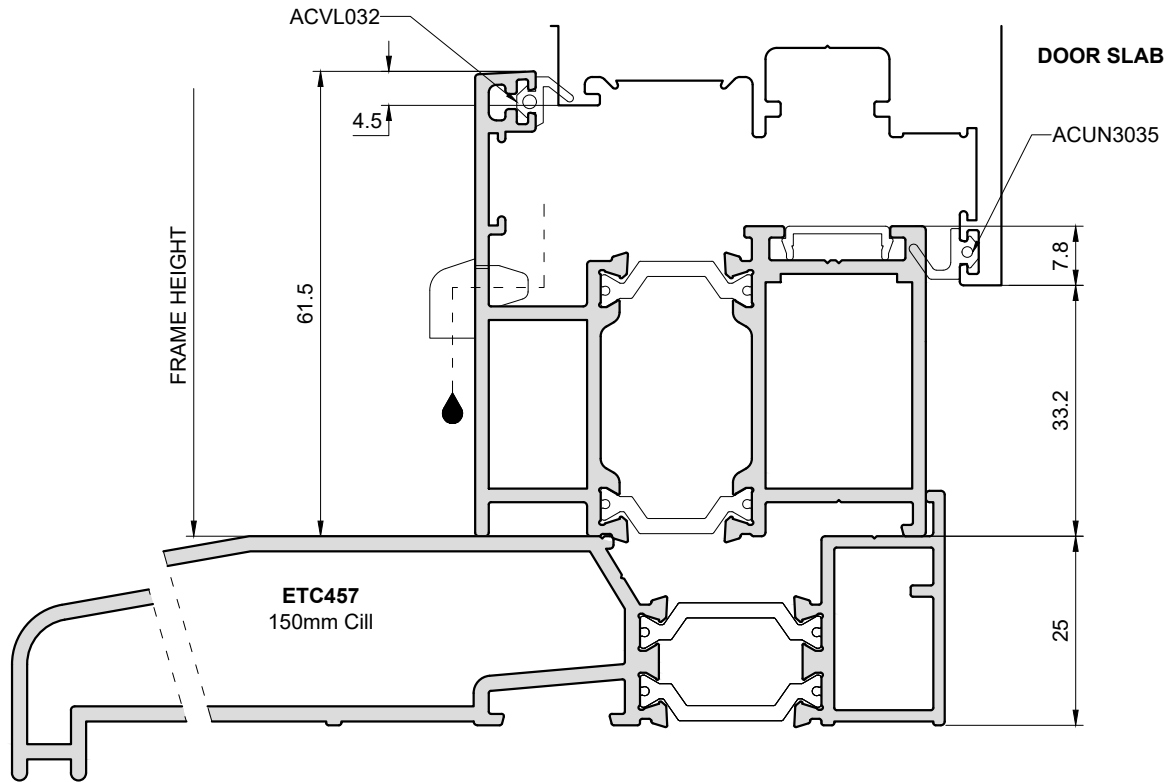

Open Out - Standard Full Frame with Cill

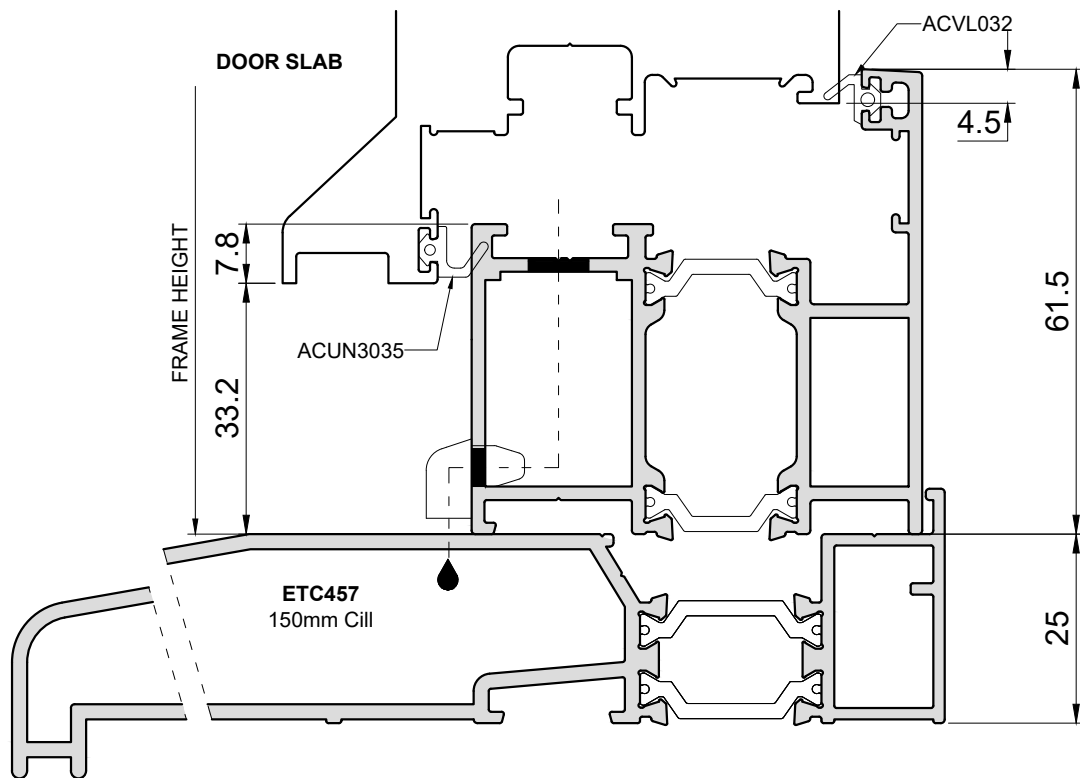

Open In - Head

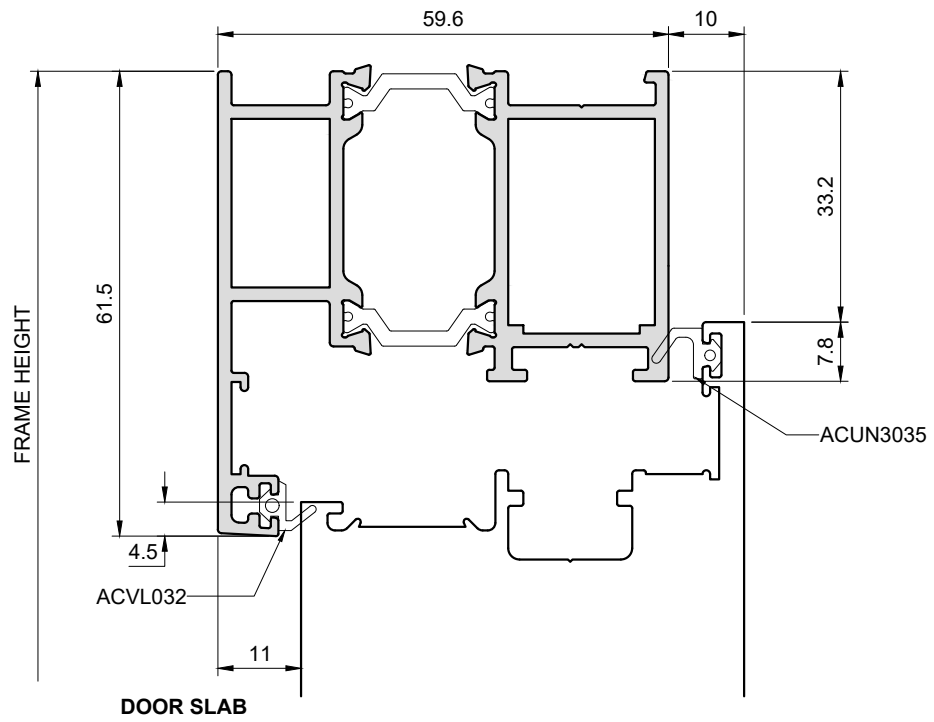

Open Out - Head

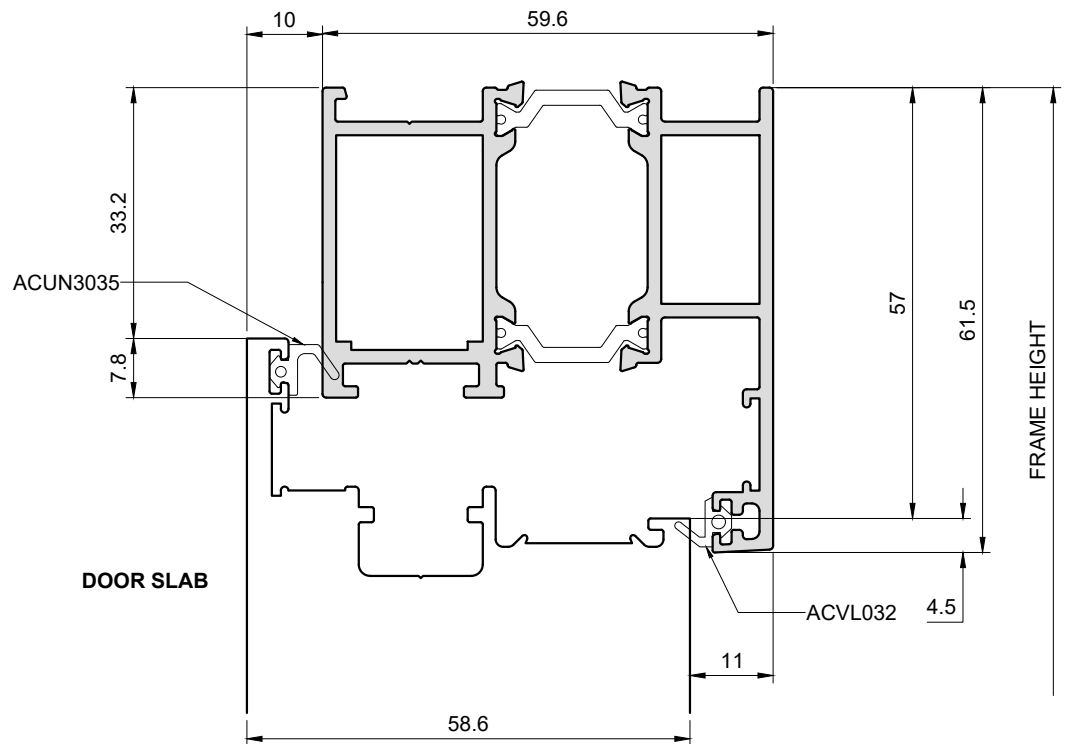

Glazing - Rounded

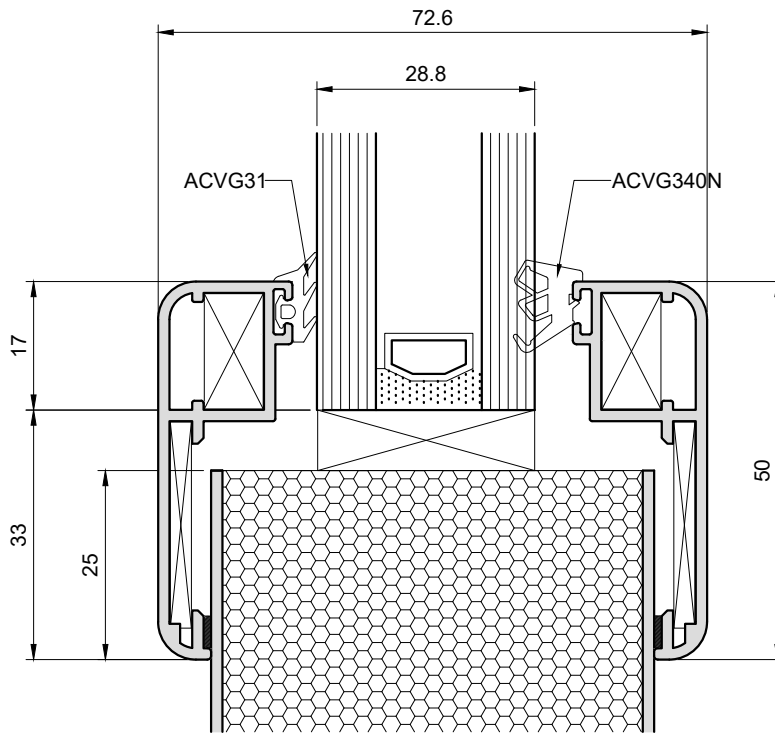

Glazing - Sloped

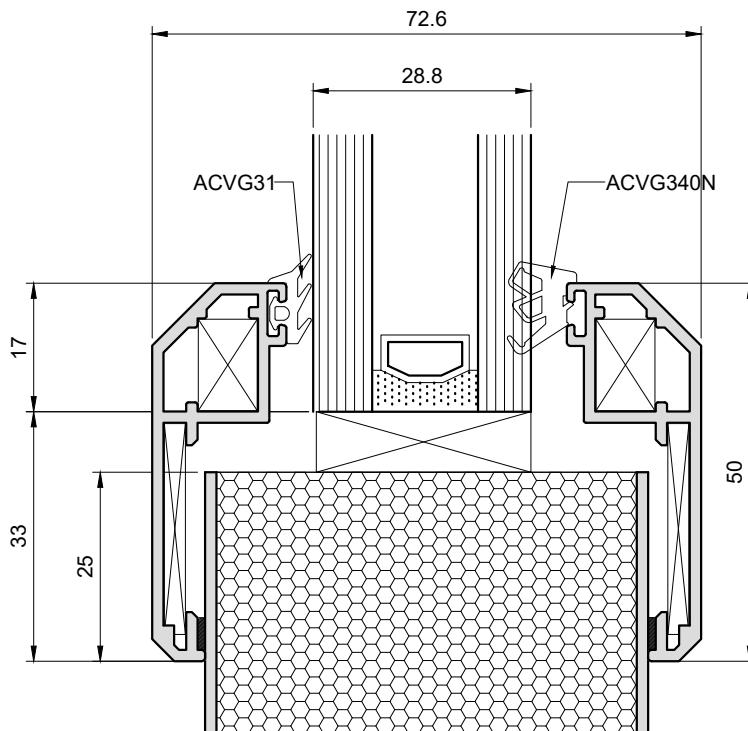

Glazing - Ovolo

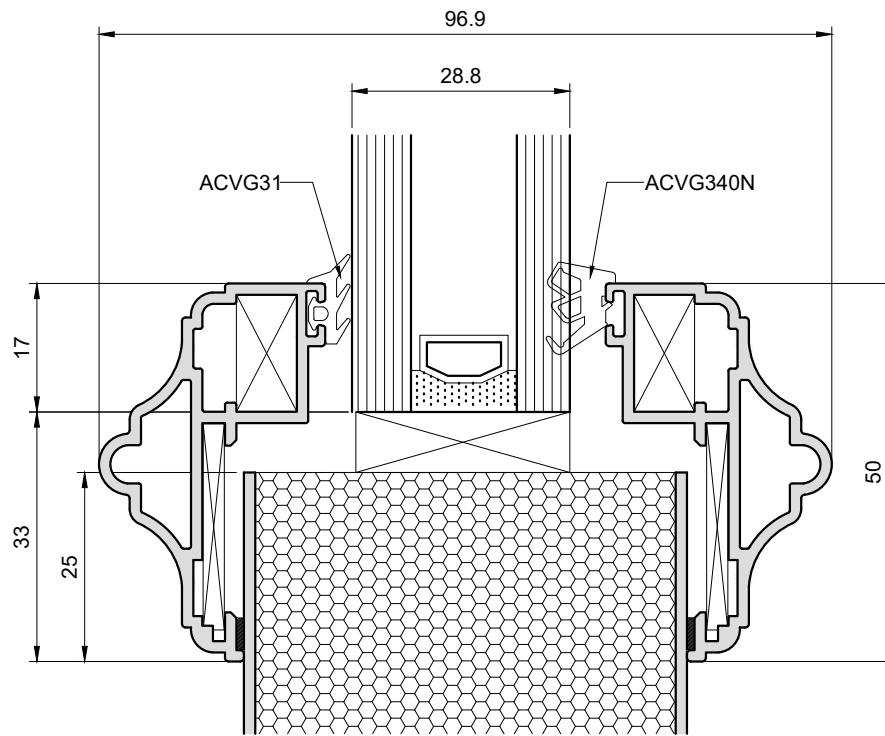

BLANK PAGE

Maintenance

Hardware

The hardware on your door is something you and your visitors touch everyday. Keeping them clean and tarnish free is an essential part of looking after your door.

1. Using a non-abrasive cloth and warm light detergent, ensure that all foreign contaminants are removed. Rinse with clean water.
2. Dry the hardware immediately to avoid streaks. Polish and buff the hardware with a soft, lint free cloth to shine.

Important

- Do not use acid-based cleaning products or any other aids.
- Do not use an abrasive cloth to wipe away excess oil. This will damage the surface finish.

To maintain the appearance of any stainless steel hardware we recommend you use only the Stainless Steel Care Kit included with your door. Before you begin, carefully mask the powder coated finish of your door's sash using either masking tape or decorators tape.

1. Use a small amount of Smart Stainless Steel Cleaning Fluid on a micro-fibre cloth to clean the hardware. Ensure the product is spread evenly and remove any excess with a clean cloth (highly concentrated do not over apply).
2. Use a small amount of Smart Care Oil on a micro-fibre cloth and wipe the oil in the direction of the stainless steel grain. Remove any excess with a clean cloth. To finish, softly buff the oil to a sparkling finish with a clean micro-fibre cloth.

Lock Maintenance

Knowing how to maintain your locks properly can help keep your home and family safe. Regular cleaning and lubrication every 3-6 months is recommended to keep your locks operating like new and will also help prevent freezing in cold weather.

1. It is important that the lock points are free of dirt and debris as this can impede the smooth operation of your lock. Use a small brush (a paint brush is ideal) to loosen any debris.
2. Place a protective sheet under the door, beneath the lock to protect your floor or carpet.
3. Check all movable and locking components for correct operation
4. Lightly grease all protruding latching and bolts. **DO NOT USE OIL.** Use acid-free multi-purpose grease e.g. Fuhr contact grease (art. no. VNZ80077).
5. Check all locking points for wear and tear and a firm fitting.

6. Depending on usage, fixing screws may have to be tightened or replaced if damaged.
7. Only use cleaning products that do not affect hardware anti-corrosion coatings.

Important

- Take care when applying to not get cleaning products or grease on powder coating.
- Oil based products, for example WD40, should not be used on locks. This works as a degreaser and will impede performance and may even damage lock mechanism.
- Take good care of your keys, a damaged key can cause damage to your cylinder.

Threshold & Seals

The build up of dirt and debris in a threshold can impede the performance and operation of your new door. Therefore we recommend cleaning your threshold every 6 months.

1. It is important that the door's threshold is clean and free from stones and any debris (leaves, accumulation of dirt etc) as this can impede the smooth operation of your door and can affect drainage.
2. Use a small brush (a paint brush is ideal) to loosen any debris from the threshold and then using a vacuum, remove the dirt that has been collected.
3. Ensure that the two drainage slots at either end of the threshold are not blocked and are free of debris.
4. Use a small brush to loosen any debris from the drainage slots and then vacuum away the dirt.

Fitted around the perimeter of the door sash and frame are rubber seals. To keep the seals in good condition to prevent drafts & loss of heat from your home we recommend cleaning the rubber seals every six months.

1. To clean the rubber seals, gently run across them with a light soapy solution and non-abrasive cloth.

Important

Do not use solvent-based cleaning products on the seals. We recommend you use a silicone-based spray on the seals twice a year (or more regularly if needed).

Paint

Doors are low maintenance and easy to take care of. Wiping your door and frame with fresh water and a light detergent once a month will help to prevent the build up of dirt. To preserve a stunning look all year round follow our simple guide.

Do Not Use:

- Any type of heavy duty household cleaner, as this may damage the powder coat finish of the frame and door surface
- Solvent based cleaning fluid (such as cellulose thinners or nail polish remover) these will cause irreversible damage to the door.
- Abrasive or aggressive materials (such as wire wool, sand paper, scouring pads or abrasive cloths) or tools (such as scrapers or knives) as this will damage the surface finish.

1. If your house is located in a marine or coastal environment, the external surface of the doors and frames should be washed down with fresh clean water on a weekly basis to remove any salt deposits that can build up.
2. It is preferable to clean the metal when shaded. Do not attempt to clean surfaces when heated by the sun, as it is possible that chemical reactions will be highly accelerated and cause damage to the surface. Also avoid cleaning in freezing temperatures.
3. For harder to clean smudges and smears, we recommend using Loctite 7070 cleaner.

Glass

Glazed doors are a beautiful addition to a home. But as they are exposed to wind, rain, fingerprints and marks, occasionally they need a good clean. Follow our simple guide to keep your glazing clean and smudge free.

1. Using a non-abrasive, window cleaning solution and a soft clean cloth or sponge gently wipe away any dirt on the glazing.
2. Rinse the glass immediately with clean water to remove the cleaning solution
3. After you have finished cleaning the glass, wipe away any cleaning solution from the glazing's gaskets, seals and frame with clean water.
4. After you have finished cleaning the glass, wipe away any cleaning solution from the glazing's gaskets, seals and frame with clean water.

Important

- Do not use razor blades or scrapers to clean the glass; this carries a high risk of causing irreparable damage to the glass.
- Do not use acid-based cleaning products or any other aids.

Please note:

If 3rd party glass unit is used, please follow the cleaning and maintenance guide from supplier. Take special care not to use any cleaning or maintenance products that may damage other aspects of door.

Contact Information

Smart Systems Limited
Arnolds Way
Yatton
Bristol
BS49 4QN
UK

www.smartsystems.co.uk

T: +44 (0) 1934 876 100

F: +44 (0) 1934 835 169

Sales: sales@smartsystems.co.uk

Technical: technical@smartsystems.co.uk